

r.LiNK Video-inserter RL3-NAC



**Compatible with
Citroen, Peugeot and Toyota vehicles
with NAC or RCC infotainment
Opel vehicles with Navi 5.0 (NAC low)**

**Video-inserter with 2 video inputs,
1 rear-view camera input and CAN control**

Product features

- Video-inserter for factory infotainment systems
- 2 CVBS video-inputs for after-market devices (e.g. DVD-Player, DVB-T tuner)
- 1 Rear-view camera CVBS video-input
- Automatic switching to rear-view camera input on engagement of reverse gear
- Activatable parking guide lines for the rear-view camera (not available for all vehicles)
- Video-in-motion in drive mode (ONLY for connected video-sources)
- Video-inputs NTSC compatible

Contents

1. Prior to installation

- 1.1. Delivery contents
- 1.2. Checking the compatibility of vehicle and accessories
- 1.3. Warning notes
- 1.4. Connection Video-Interface
- 1.5. Settings of the 8 Dip switches (black)
 - 1.5.1. Enabling the interface's video inputs (dip 2-3)
 - 1.5.2. Rear-view camera setting (dip 5)
 - 1.5.3. Choosing the corresponding head unit version (dip 8)
- 1.6. Settings of the 4 Dip switches (CAN function – red)

2. Installation

- 2.1. Place of installation – video interface
- 2.2. Connection schema
- 2.3. Connection to the head-unit
 - 2.3.1. Connection LVDS – video interface
 - 2.3.1.1. High version head unit (2 X 4 PIN HSD)
 - 2.3.1.2. Low version head unit (1 X 4 PIN HSD)
 - 2.3.2. Connection to the head-unit – Power / CAN
 - 2.3.3. Analog power supply for the video interface
- 2.4. Connection - video sources
 - 2.4.1. Audio insertion
 - 2.4.2. After-market rear-view camera
 - 2.4.2.1. Case 1: Video-interface receives the reverse gear signal
 - 2.4.2.2. Case 2: Video interface does not receive the reverse gear signal
- 2.5. Connection - video-interface and external keypad
- 2.6. Picture settings and guide lines

3. Interface operation

- 3.1. By NAVI button
- 3.2. By external keypad

4. Specifications

5. FAQ – Trouble shooting

6. Technical support

Legal Information

By law, watching moving pictures while driving is prohibited, the driver must not be distracted. We do not accept any liability for material damage or personal injury resulting, directly or indirectly, from installation or operation of this product. Apart from using this product in an unmoved vehicle, it should only be used to display fixed menus or rear-view-camera video when the vehicle is moving (for example the MP3 menu for DVD upgrades).

Changes/updates of the vehicle's software can cause malfunctions of the interface. Up to one year after purchase we offer free software-updates for our interfaces. To receive a free update, the interface has to be sent in at own cost. Wages for de-and reinstallation and other expenditures involved with the software-updates will not be refunded.

1. Prior to installation

Read the manual prior to installation. Technical knowledge is necessary for installation. The place of installation must be free of moisture and away from heat sources.

1.1. Delivery contents

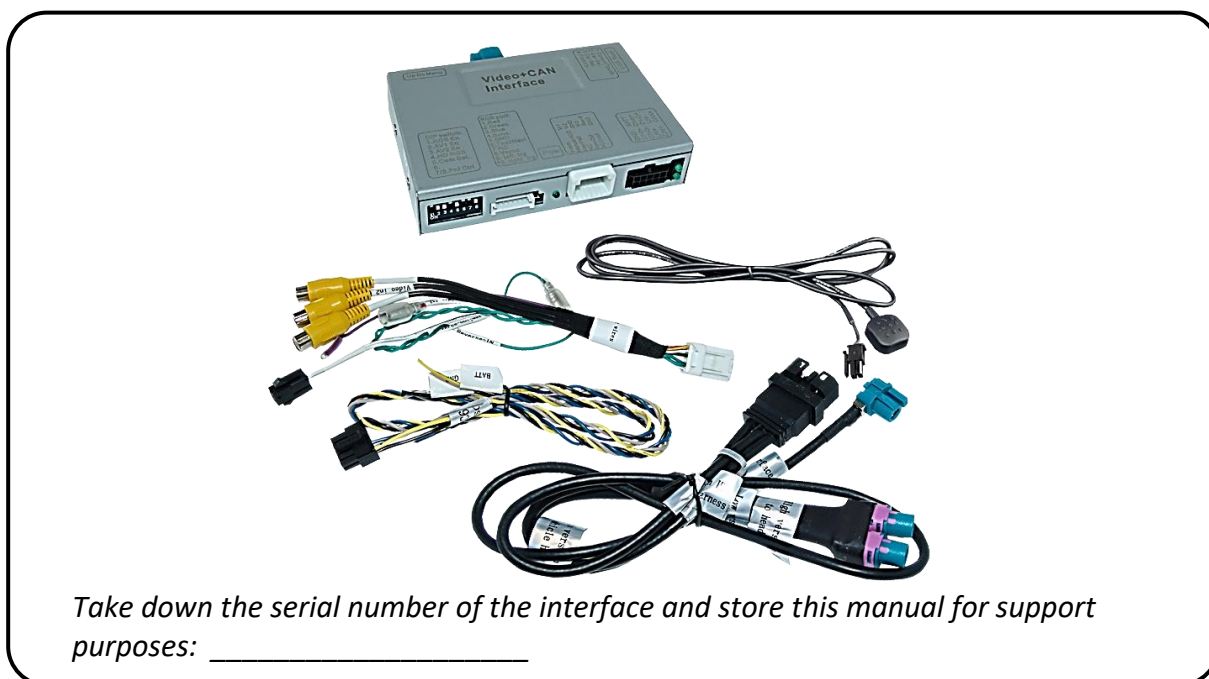

1.3. Warning notes:

Damage to the head-unit is possible, if this RL3-NAC interface is installed to older Citroen / Peugeot SMEG or SMEG+ head-units (by Magneti Marelli)! Use this RL3-NAC interface only on Citroen/Opel/Peugeot/Toyota head-units NAC (by Continental) or RCC (Bosch). Designs and features – see the following pictures:



Furthermore, even when installed to the correct NAC systems, there is also **damage** to the head-unit possible **if the 4pin HSD connectors of this harness are wrong-plugged.**

Prior to installation must be determined whether the head-unit of the vehicle is a

low version head-unit

(single black male 4pin HSD on backside)



OR

high version head-unit

(double black male 4pin HSD on the backside)



Please, carefully follow the manual for high or low version connection of the head unit!

1.4. Connection - Video-Interface

The video-interface converts the video signals of connected after-market sources in a factory monitor compatible picture signal which is inserted in the factory monitor, by using separate trigger options. Further it reads the vehicle's digital signals out of the vehicle's CAN-bus and converts them for the video interface.

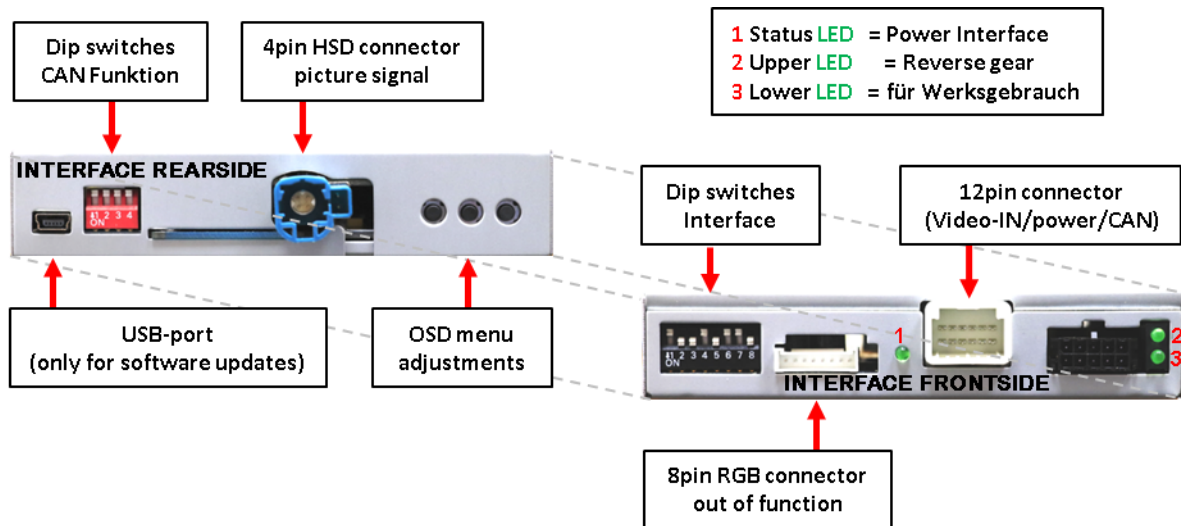

1.5. Settings of the 8 Dip switches (black)

Some settings have to be selected by the 8 dip-switches at the video-interface. Dip position down is ON and position up is OFF.



Dip	Function	ON (down)	OFF (up)
1	No function		set to OFF
2	CVBS AV1-input	enabled	disabled
3	CVBS AV2-input	enabled	disabled
4	No function		set to OFF
5	Rear-view cam type	after-market	factory or none
6	No function		set to OFF
7	No function		set to OFF
8	Picture customizing Head unit	Try the 2 possible settings of dip 8 to find the best picture (quality and size)	

See the following chapters for detailed information.

After each Dip-switch-change a power-reset of the Can-box has to be performed!

1.5.1. Enabling the interface’s video inputs (dip 2-3)

Only the enabled video inputs can be accessed when switching through the interface’s video sources. It’s recommended to enable only the required inputs, for the disabled will be skipped when switching through the video interfaces inputs.

1.5.2. Rear-view camera setting (dip 5)

If set to **OFF**, the interface switches to factory LVDS picture while the reverse gear is engaged to display a factory rear-view camera or a factory optical park system picture.

If set to **ON**, the interface switches to its rear-view camera input “Camera-IN” while the reverse gear is engaged.

Note: Dip 1, 4, 6 and 7 are out of function and have to be set to **OFF**.

1.5.3. Choosing the corresponding head unit version (dip8)

If set to **ON**, the video interface will communicate with the NAC low-version head unit.

If set to **OFF**, the high version of the head unit will be adjusted.

Note: Dip 1,4,6 and 7 are out of function and have to be set to **OFF**.

1.6. Settings of the 4 Dip switches (CAN function - red)

Dip position down is **ON** and position up is **OFF**.



Navigation / Sy5tem	Dip 1	Dip 2	Dip 3	Dip 4
NAC infotainments	OFF	OFF	OFF	OFF

Set all 4 dips to OFF.

After each Dip-switch-change a power-reset of the Can-box has to be performed!

2. Installation

Switch off the ignition and disconnect the vehicle's battery! The interface needs a permanent 12V source. If -according to factory rules- a disconnection of the battery has to be avoided, it should be sufficient to use the vehicle's sleep-mode. In case, the sleep-mode doesn't succeed, the battery has to be disconnected with a resistor lead.

The Interface needs a permanent power supply! If power isn't directly taken from the battery, the connection's power has to be checked for being start-up proven and permanent.

Before the final installation, we recommend a test-run of the interface. Due to changes in the production of the vehicle manufacturer, there's always the possibility of incompatibility.

2.1. Place of installation – video-interface

The video-interface is performed to be installed at the head unit's rear side.

Note: The radio/Navi of **Peugeot 2008 BJ 2019** vehicles is installed straight behind the display.

2.2. Connection schema

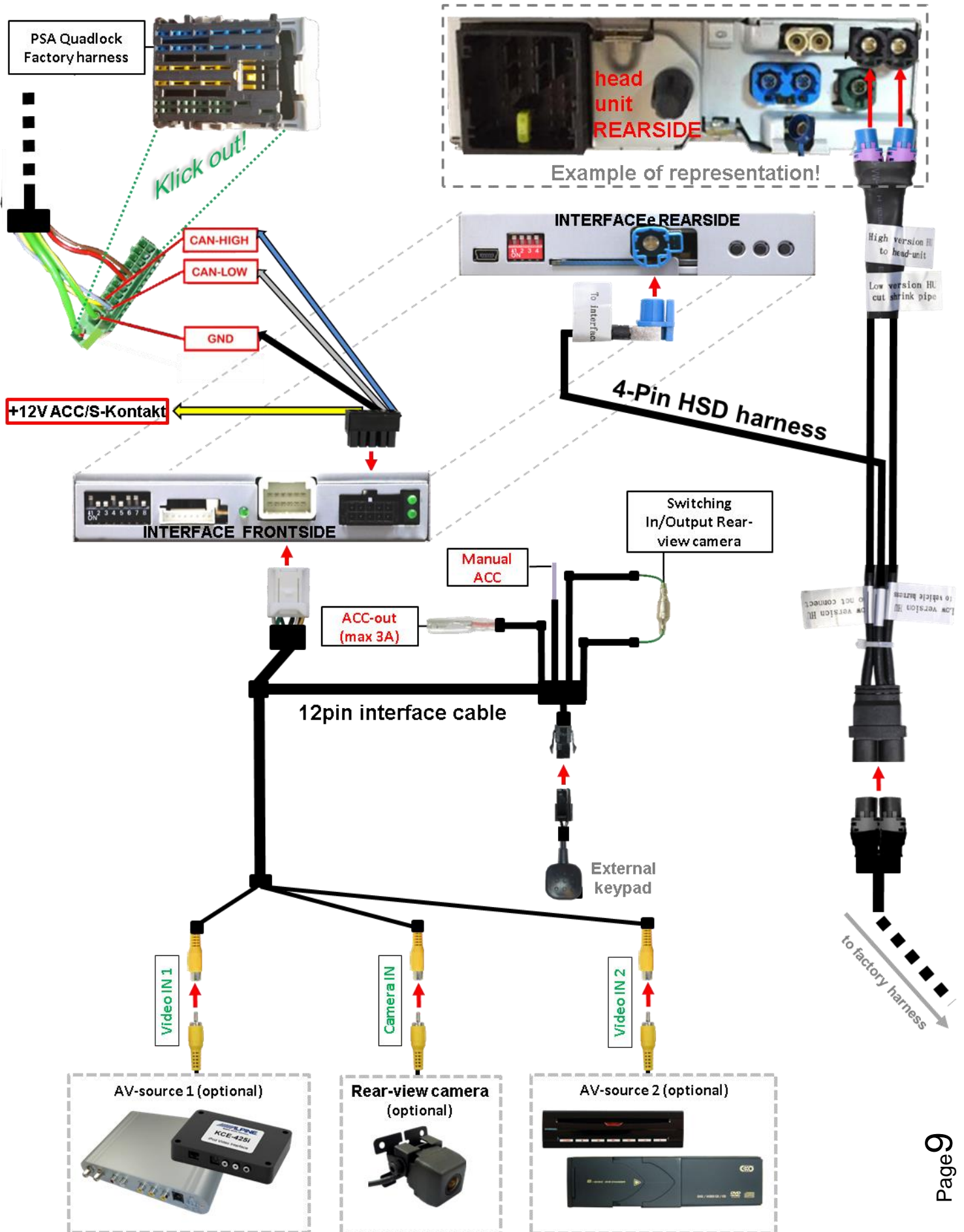

2.3.1.2. Low version head unit (1 X 4pin HSD)

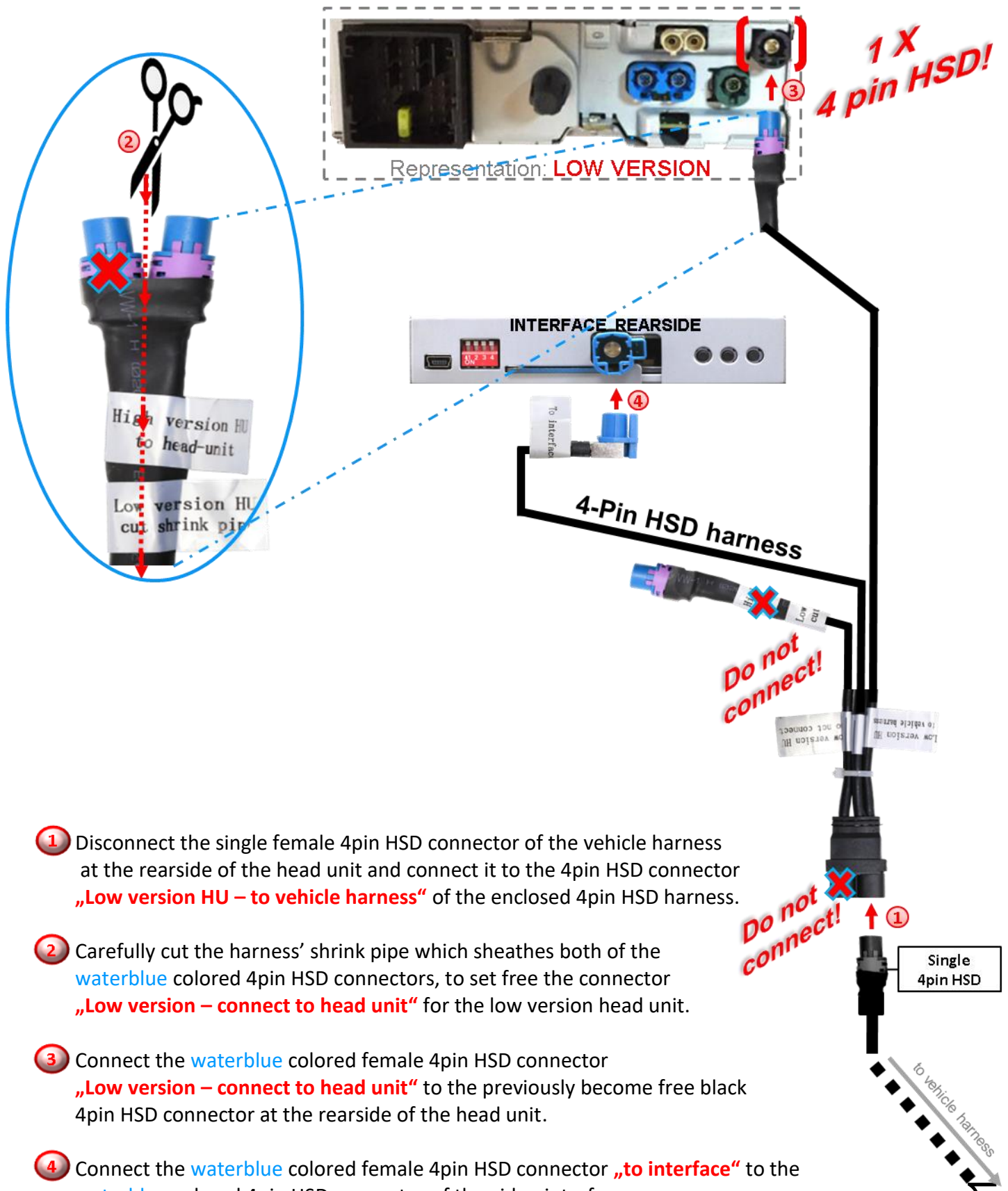

- ① Disconnect the single female 4pin HSD connector of the vehicle harness at the rearside of the head unit and connect it to the 4pin HSD connector „**Low version HU – to vehicle harness**“ of the enclosed 4pin HSD harness.
- ② Carefully cut the harness' shrink pipe which sheathes both of the **waterblue** colored 4pin HSD connectors, to set free the connector „**Low version – connect to head unit**“ for the low version head unit.
- ③ Connect the **waterblue** colored female 4pin HSD connector „**Low version – connect to head unit**“ to the previously become free black 4pin HSD connector at the rearside of the head unit.
- ④ Connect the **waterblue** colored female 4pin HSD connector „**to interface**“ to the **waterblue** colored 4pin HSD connector of the video interface.

2.3.2. Connection to the head unit – Power / CAN

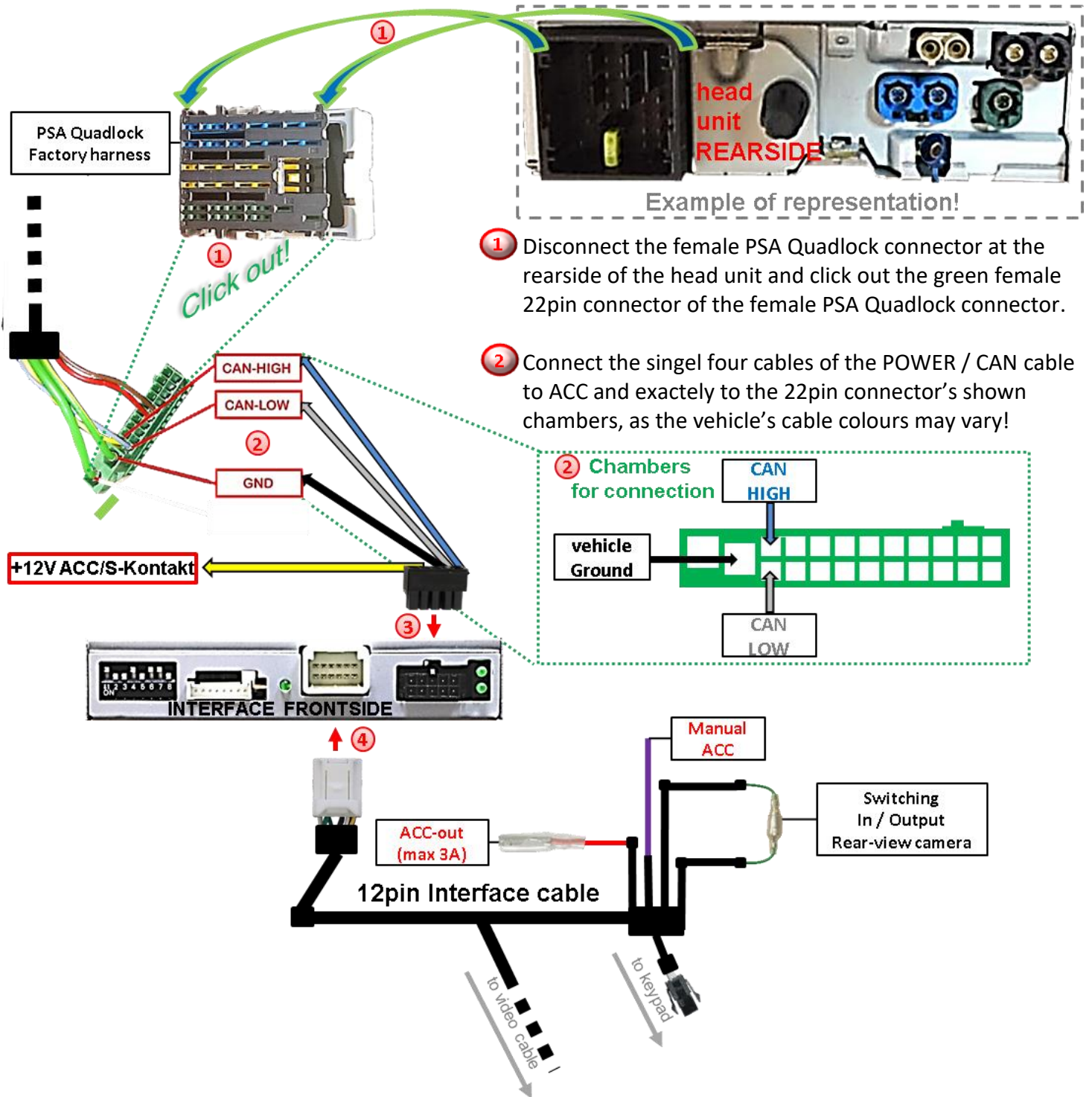

3 Connect the power / CAN cable's female 10pin connector to the 10pin connector of the video interface.

4 Connect the interface cable's female 12pin connector to the 12pin connector of the interface.



Note: The CAN communication doesn't succeed in all vehicles. If, after connecting the 10pin Power / CAN cable, no interface LED lightens up while the ignition is turned on, refer to chapter "Analogue power supply for the video interface".

2.3.3. Analog power supply for the video interface

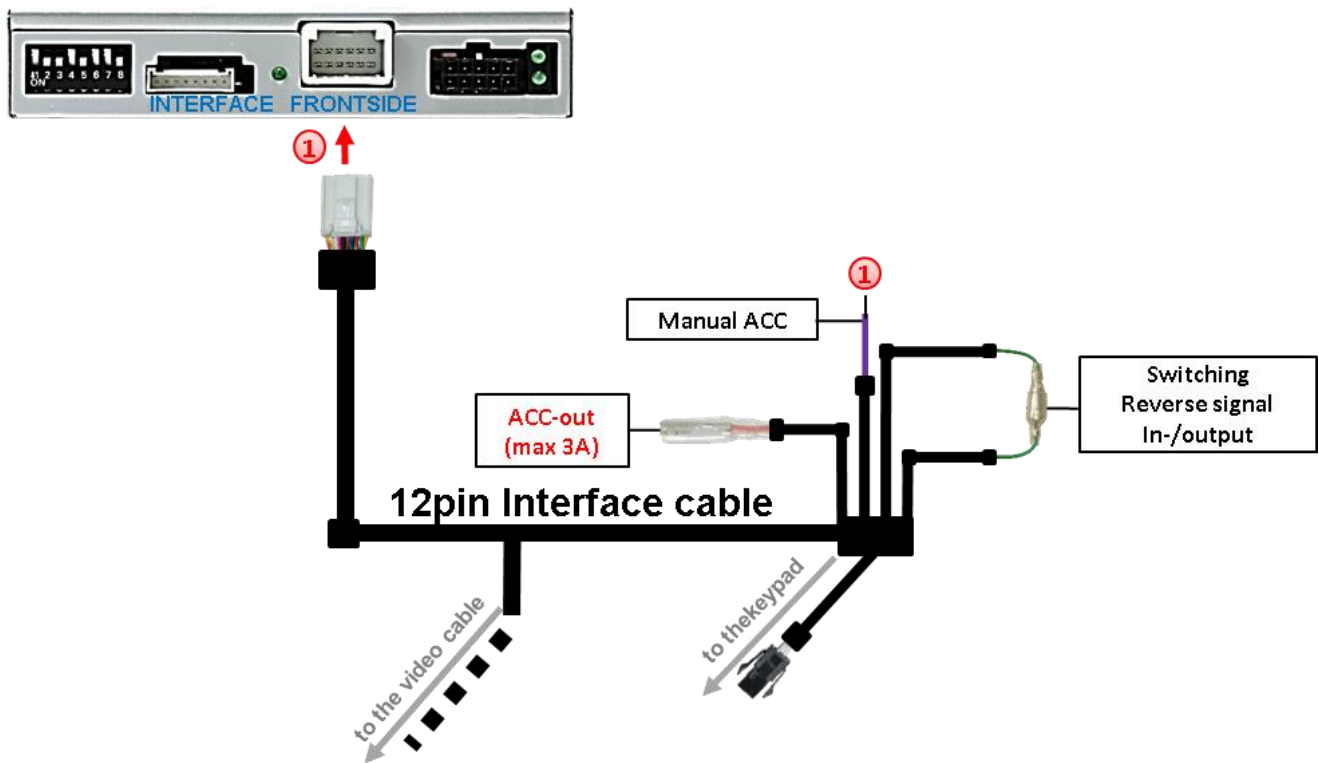

- ① Connect the 12pin interface cable's purple coloured wire **Manual ACC** to +12V **Ignition power** or to +12V **S-contact terminal 86s +12V** (e.g. glove compartment illumination).

2.4. Connection - the video sources

It is possible to connect two after-market video-sources and an after-market rear-view camera to the video-interface.

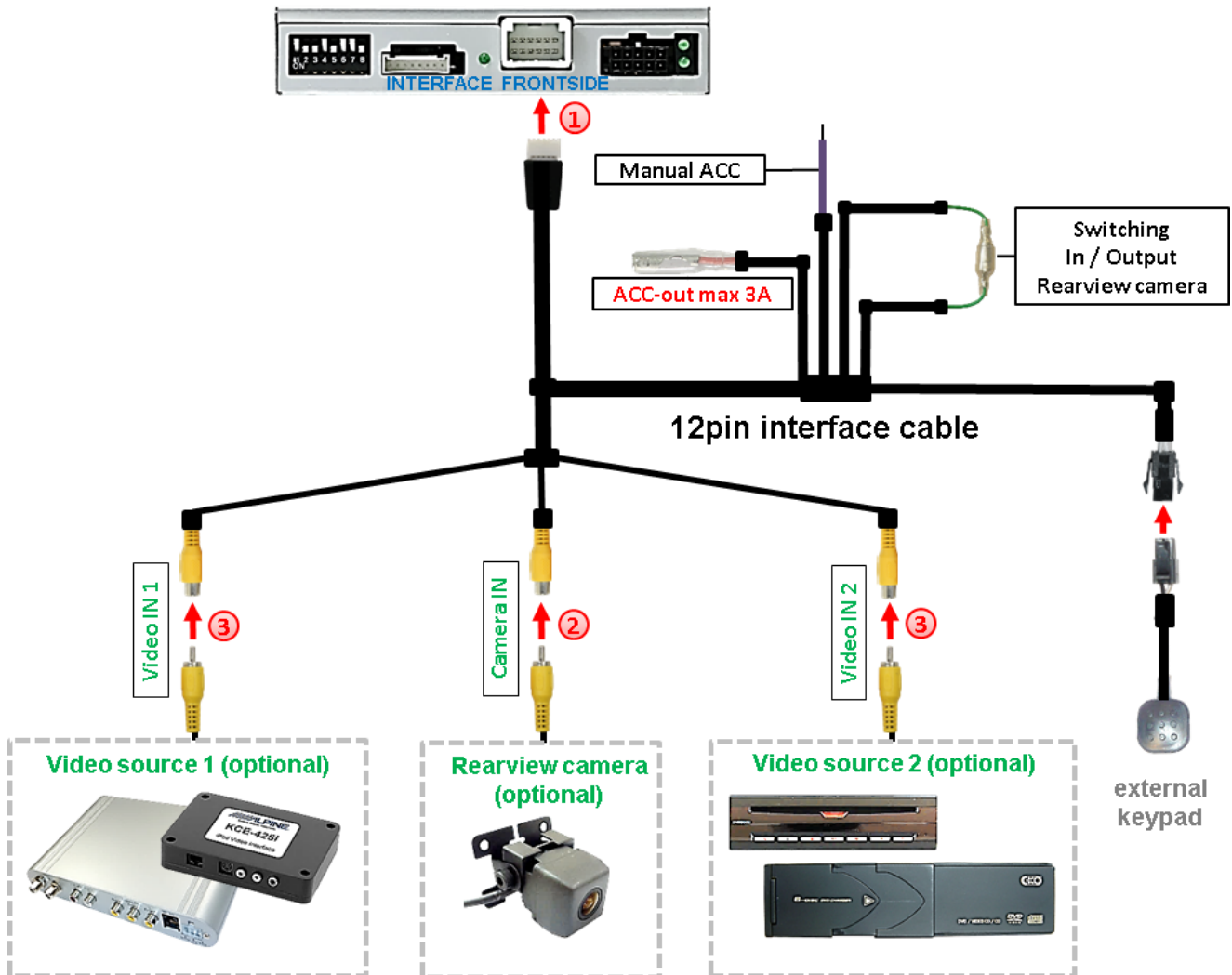

- ① Connect the 12pin interface cable’s female 12pin connector to the male 12pin connector of the video-interface.
- ② Connect the video RCA of the Rear-view camera to the 12pin interface cable’s female RCA connector „Camera IN”.
- ③ Connect the video RCA of the AV source 1 and 2 to the 12pin interface cable’s female RCA connector “Video IN 1” and ” Video IN 2”.

2.4.1. Audio insertion

This interface can only insert video signals into the factory infotainment. If an AV source is connected, the audio insertion has to be performed by a factory aux input or an FM modulator. The inserted video-signal can be activated simultaneously to each audio-mode of the factory infotainment.

If 2 AV-sources shall be connected to the infotainment, for audio switching an additional electronic part is required.

2.4.2. After-market rear-view camera

Some vehicles have a different reverse gear code on the CAN-bus which the video-interface is not compatible with. Therefore, there are two different ways of installation. If the video interface receives a signal of the reverse gear, the green wire **“Reverse-OUT”** of the 20pin cable should carry +12V while the reverse gear is engaged.

Note: Do not forget to set dip5 of the video-interface to **ON** before testing.

2.4.2.1. Case 1: Video interface receives the reverse gear signal

If the CAN-bus interface receives +12V on the green wire of the 20pin cable when reverse gear is engaged, it will automatically be switched to the rear-view camera input “Camera IN” while reverse gear is engaged.

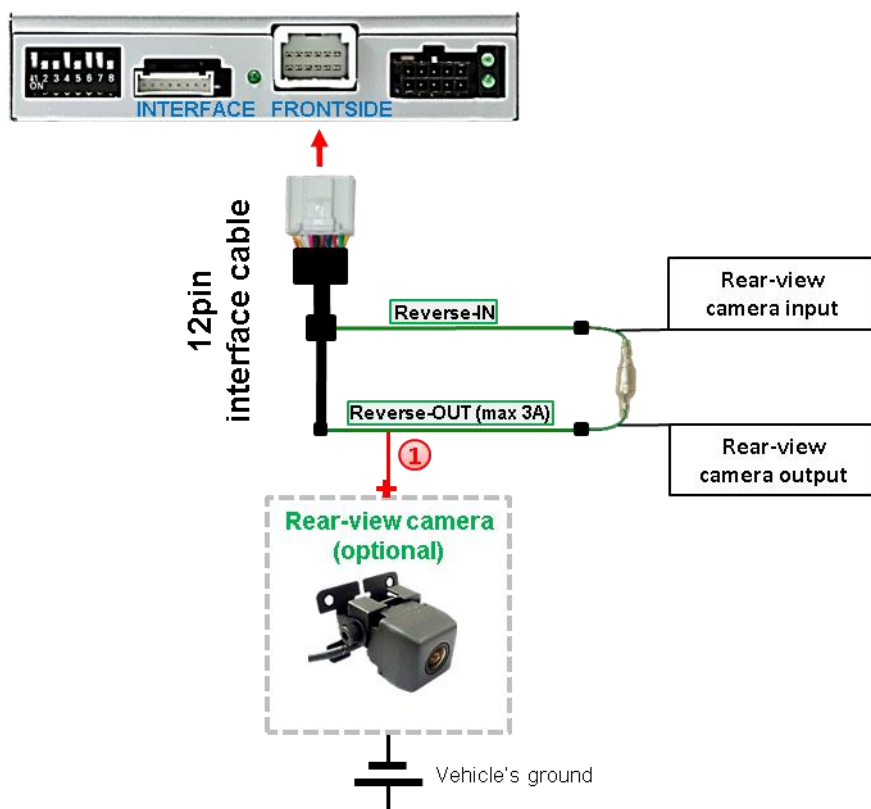

- ① The 12 V power supply for the rear-view camera (max 3A) has to be taken from the green wire of the 20pin cable to avoid an unnecessary, permanent power supply to the camera electronic.

For the operation, both green cables **“Reverse IN”** and **“Reverse OUT”** have to remain connected.

2.4.2.2. Case 2: Video interface does not receive the reverse gear signal

If the video interface does not receive +12V on the green wire of the 20pin cable when reverse gear is engaged (not all vehicles are compatible), an external switching signal from the reverse gear light is required. As the reverse gear light's power supply isn't voltage-stable all the time, an ordinary open relay (e.g AC-RW-1230 with wiring AC-RS5) or filter (e.g. AC-PNF-RVC) is required. The diagram below shows the connection type of the relay.

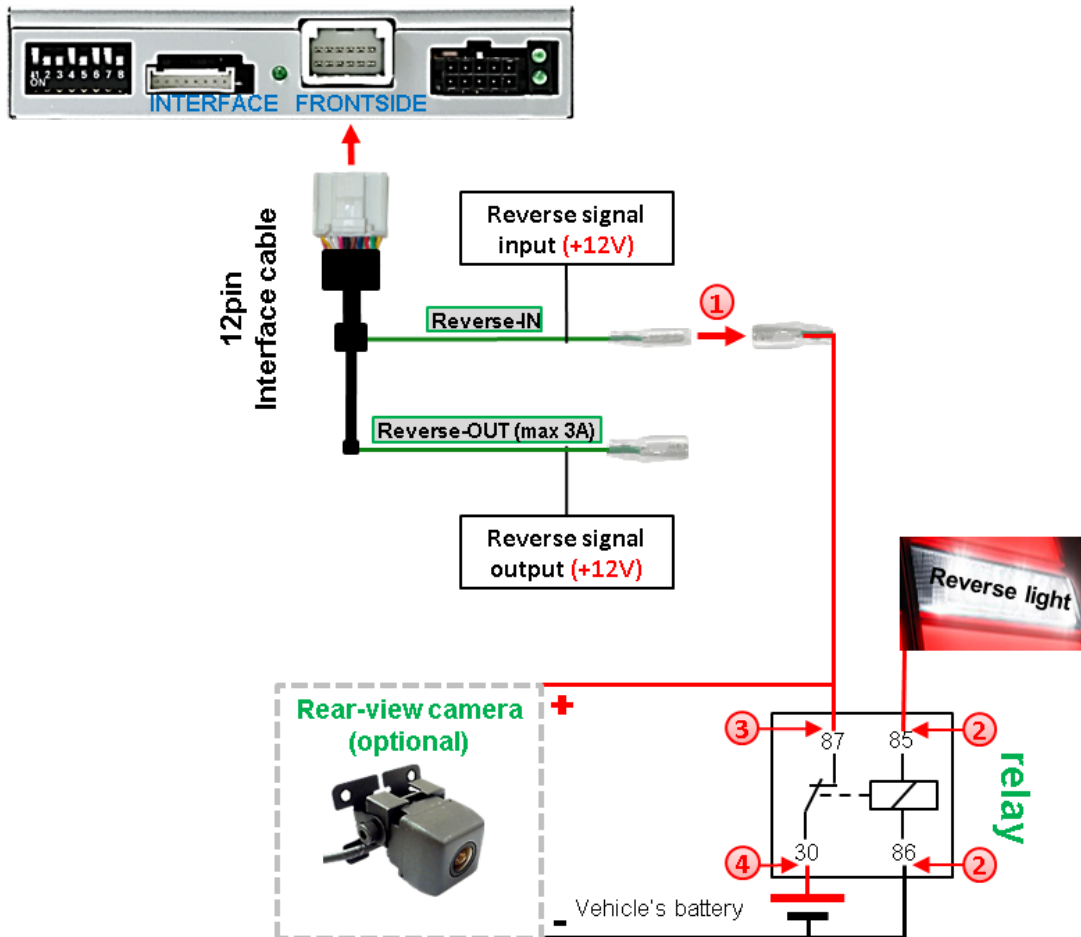

- ① Disconnect the green cable's pre-connected male- and female connectors of the 20pin cable and connect the green input cable "Reverse-IN" to the output connector (87) of the relay.

Note: Not least to avoid short circuits, the best solution should be, to crimp a male 4mm connector to the relay's output cable and connect it to the green cable's female 4mm connector. The output-cable "Reverse-OUT" remains disconnected as it's out of function.

- ② Connect the Reverse light's power-cable to coil (85) and the vehicle's ground to coil (86) of the relay.
- ③ Connect the output connector (87) of the relay to the rear-view camera's power-cable, like you did it to the green "Reverse-IN" cable before.
- ④ Connect permanent power / 12V to the relay's input connector (30).

2.5. Connection - video-interface and external keypad

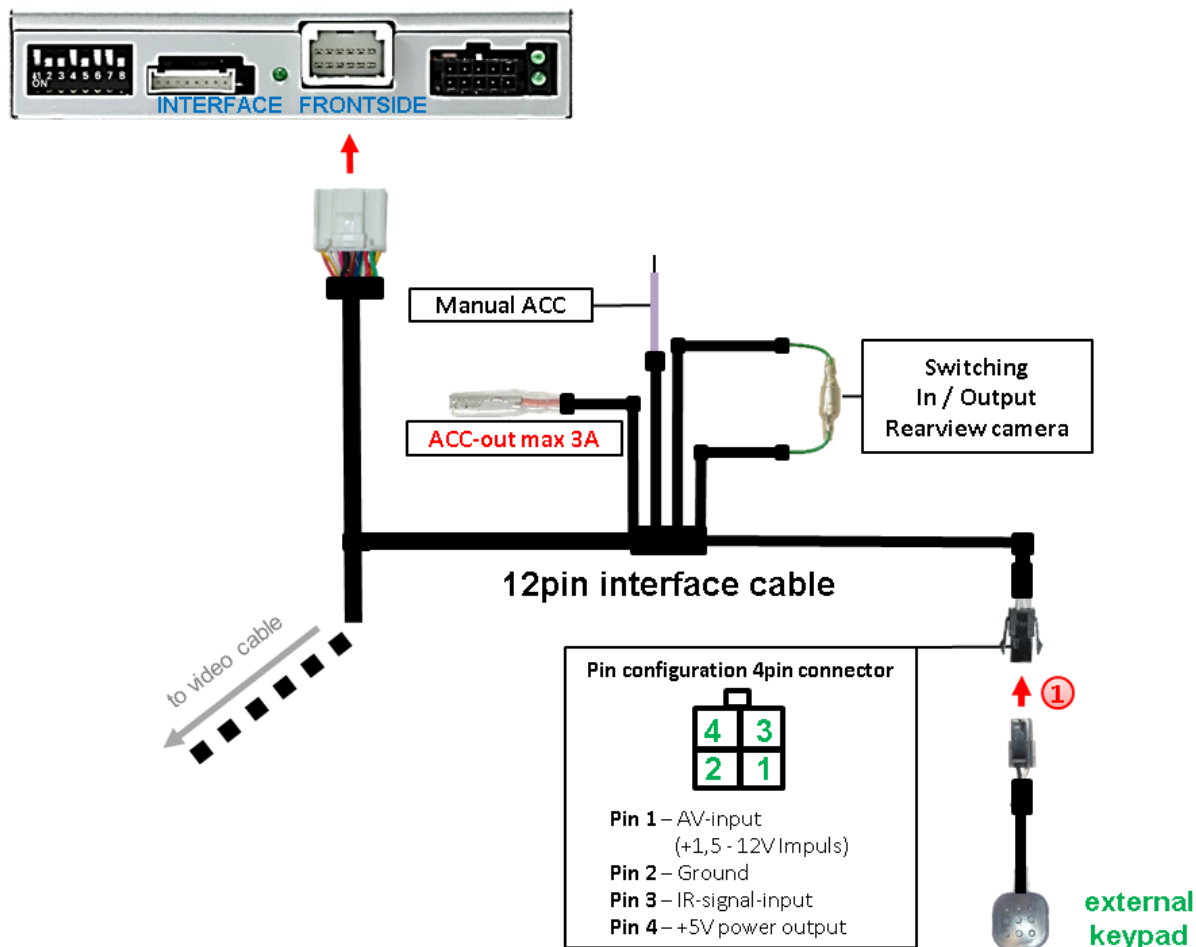

- 1 Connect the keypad's female 4pin connector to the video-interface's male 4pin connector.

Note: Even if the switching through several video sources by the keypad mightn't be required, the invisible connection and availability is strongly recommended.

2.6. Picture settings and guide lines

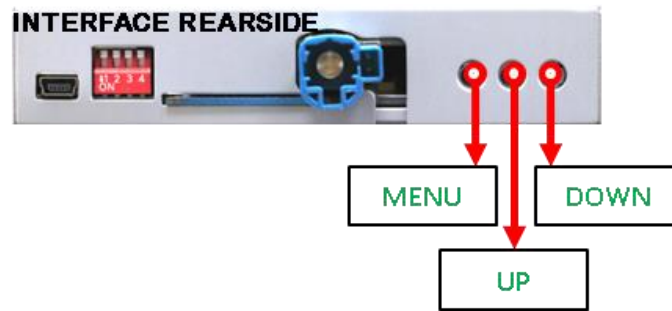

The picture settings can be adjusted by the 3 buttons on the video-interface. Press the **MENU** button to open the OSD settings menu. To switch to the next menu item, pressing **UP** and **DOWN** will change the selected value. The buttons are embedded in the housing to avoid accidental changes during or after installation. The picture settings have to be done separately for AV1 and AV2 while the corresponding input is selected and visible on the monitor.

Note: The OSD menu is only shown when a working video source is connected to the selected video-input of the interface.

The following settings are available:

- Contrast
- Brightness
- Saturation
- Position H (horizontal)
- Position V (vertical)
- IR-AV1 (out of function)
- IR-AV2 (out of function)
- Guide-lines left
- Guide-lines right
- U1-CNTRL - Guide lines for rear-view camera (ON/OFF)
- H-SIZE (horizontal) picture adjustment
- V-SIZE (vertical) for rear-view camera



Options:

- All ON:** Guide lines and PDC will be displayed.
- PDC ON:** Only PDC displayed.
- Guide ON:** Only Guide lines displayed.
- ALL Off:** Guide lines and PDC will not be displayed.

The menu's point „U1 CNTRL“ does support the guide lines options like shown beside:

Note: If the vehicle's CAN communication does not support the video interface, the guide-lines cannot be used, even if they're once shown with the first operation!

3. Interface operation

3.1. By Navi button

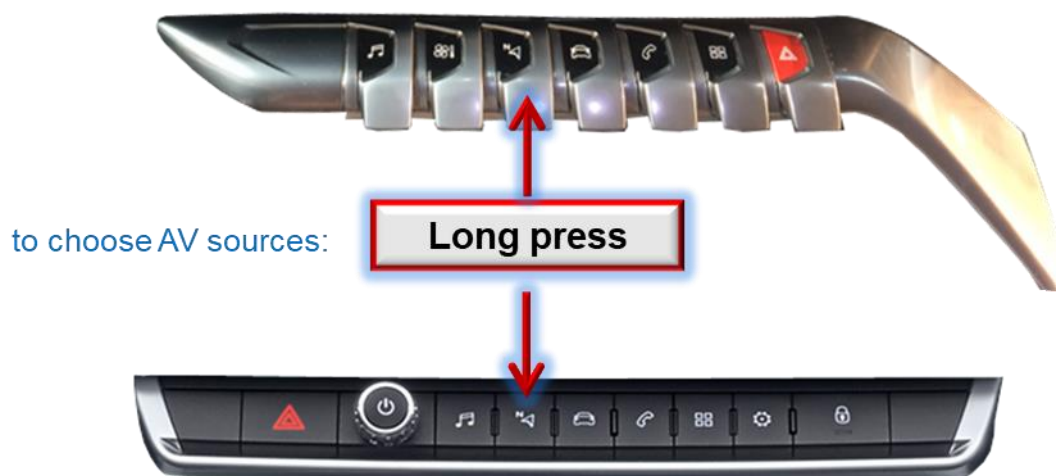

to choose AV sources:

Long press

A long press of the infotainment's "Navi"-button switches the input from factory mode to the inserted video sources. If, by dip switch setting, all inputs are enabled, the order is the following:

Factory video → video IN1 → video IN2 → factory video →...

By dip switch deactivated inputs will be skipped.

Switchover by vehicle buttons isn't possible in all vehicles. In some vehicles the external keypad has to be used.

3.2. By keypad

Alternatively or additionally to the infotainment's "Navi" button, the interface's enabled inputs can also be switched by the external keypad.

4. Specifications

BATT/ACC range	7V - 25V
Stand-by power drain	5mA
Power	240mA @12V
Video input	0.7V – 1V
Video input formats	NTSC
Temperature range	-40°C to +85°C
Dimensions Video-Box	118 x 23 x 105 mm (W x H x D)

5. FAQ – Trouble shooting Interface functions

For any troubles which may occur, check the following table for a solution before requesting support from your vendor.

Symptom	Reason	Possible solution
No picture/black picture (factory picture).	Not all connectors have been reconnected to factory head-unit or monitor after installation.	Connect missing connectors.
	No power on CAN-bus box (all LED CAN-bus box are off).	Check power supply of CAN-bus box. Check CAN-bus connection of CAN-bus box.
	CAN-bus box connected to CAN-bus in wrong place.	Refer to the manual where to connected to the CAN-bus. If not mentioned, try another place to connect to the CAN-bus.
	No power on video-interface (all LED video-interface are off).	Check whether CAN-bus box delivers +12V ACC on red wire output of 8pin to 6pin cable. If not cut wire and supply ACC +12V directly to video-interface.
No picture/black picture/white picture (inserted picture) but factory picture is OK.	No picture from video source.	Check on other monitor whether video source is OK.
	No video-source connected to the selected interface input.	Check settings dips 1 to 3 of video interface which inputs are activated and switch to corresponding input(s).
	LVDS cables plugged in wrong place.	Double-check whether order of LVDS cables is exactly connected according to manual. Plugging into head-unit does not work when the manual says to plug into monitor and vice versa.
Inserted picture totally wrong size or position.	Wrong monitor settings of video-interface.	Try different combinations of dips 7 and 8 of video-interface. Unplug 6pin power after each change.
Inserted picture double or 4 times on monitor.		
Inserted picture distorted, flickering or running vertically.	Video sources output set to AUTO or MULTI which causes a conflict with the interfaces auto detection.	Set video source output fixed to PAL or NTSC. It is best to set all video sources to the same standard.
	If error occurs only after source switching: Connected sources are not set to the same TV standard.	Set all video sources to the same standard.
	Some interfaces can only handle NTSC input.	Check manual whether there is a limitation to NTSC mentioned. If yes, set source fixed to NTSC output.
Inserted picture b/w.	Picture settings have not been adjusted.	Use the 3 buttons and the interface's OSD to adjust the picture settings for the corresponding video input.
Inserted picture qual. bad.		
Inserted picture size slightly wrong.		
Inserted picture position wrong.		
Camera input picture flickers.	Camera is being tested under fluorescent light which shines directly into the camera.	Test camera under natural light outside the garage.
Camera input picture is bluish.	Protection sticker not removed from camera lens.	Remove protection sticker from lens.

Symptom	Reason	Possible solution
Camera input picture black.	Camera power taken directly from reverse gear lamp.	Use relay or electronics to "clean" reverse gear lamp power. Alternatively, if CAN-bus box is compatible with the vehicle, camera power can be taken from green wire of 6pin to 8pin cable.
Camera input picture has distortion.		
Camera input picture settings cannot be adjusted.	Camera input picture settings can only be adjusted in AV2 mode.	Set dip 3 of video-interface to ON (if not input AV2 is not already activated) and connect the camera to AV2. Switch to AV2 and adjust settings. Reconnect camera to camera input and deactivate AV2 if not used for other source.
Graphics of a car in camera input picture.	Function PDC is ON in the interface OSD.	In compatible vehicles, the graphics will display the factory PDC distance. If not working or not wanted, set interface OSD menu item UI-CNTRL to ALLOFF.
Chinese signs in camera input picture	Function RET or ALL is ON (function for Asian market) in the interface OSD.	Set interface OSD menu item UI-CNTRL to ALLOFF or PDCON.
Not possible to switch video sources by OEM button.	CAN-bus interface does not support this function for vehicle.	Use external keypad or cut white wire of 6pin to 8pin cable and apply +12V impulses for AV-switching.
Not possible to switch video sources by external keypad.	Pressed too short.	For video source switching a longer press of about 2.5 seconds is required.
	SW-version of interface does not support external keypad.	Use OEM-button or cut white wire of 6pin to 8pin cable and apply +12V impulses for AV-switching.
Interface does not switch to camera input when reverse gear is engaged.	CAN-bus interface does not support this function for the vehicles.	Cut the green wire of the 6pin to 8pin cable and apply +12V constant from reverse gear-lamp signal. Use relay to "clean" R-gear lamp power.
Interface switches video-sources by itself.	CAN-bus interface compatibility to vehicle is limited.	Cut the grey wire of 6pin to 8pin and isolate both ends. If problem still occurs, additionally cut the white wire of 6pin to 8pin cable and isolate both ends.

6. Technical Support

Please note that direct technical support is only available for products purchased directly from NavLinkz GmbH. For products bought from other sources, contact your vendor for technical support.

NavLinkz GmbH
distribution/tech dealer-support
 Heidberghof 2
 D-47495 Rheinberg

Tel +49 2843 17595 00
 Email mail@navlinkz.de

 10R-03 5384

Made in China

