

r.LiNK Video inserter

RL4-LR17

Compatible with
Land Rover and **Jaguar** vehicles
with Incontrol Touch Pro Duo infotainment
and 10.2 inch monitor



example

**Video-inserter for front- and rear-view camera
and two additional video inputs**

Product features

- Video-inserter for factory-infotainment systems
- 1 CVBS Input for rear-view camera
- 1 CVBS Input for front camera
- 2 CVBS Video-inputs for after-market Video sources (e.g. USB-Player, DVB-T2 Tuner)
- Automatic switching to rear-view camera input on engagement of the reverse gear
- Automatic front camera switching after reverse gear for 10 seconds
- Activatable parking guide lines for rear-view camera (not available for all vehicles)
- Video-in-motion (ONLY for connected video-sources)
- Video-inputs NTSC compatible

Contents

1. Prior to installation

- 1.1. Delivery contents
- 1.2. Checking the compatibility of vehicle and accessories
- 1.3. Connection video interface
- 1.4. Settings of the 8 Dip switches (black)
 - 1.4.1. Activating the front camera input (dip 1)
 - 1.4.2. Enabling the interface's video inputs (dip 2-3)
 - 1.4.3. Rear-view camera setting (dip 5)
 - 1.4.4. Activating the guide lines (dip6)
 - 1.4.5. Activating the PDC (dip7)
 - 1.5. Settings of the 4 Dip switches (CAN function – red)

2. Installation

- 2.1. Place of installation
- 2.2. Monitor removal – example Land Rover
- 2.3. Note for test run
- 2.4. Connection schema
- 2.5. Connection – picture signal cable
- 2.6. Analog power supply for the video interface
- 2.7. Power supply output
- 2.8. Connection - video-sources
 - 2.8.1. Audio insertion
 - 2.8.2. After-market front camera
 - 2.8.3. After-market rear-view camera
 - 2.8.3.1. Case 1: Interface receives the reverse gear signal
 - 2.8.3.2. Case 2: Interface does not receive the reverse gear signal
- 2.9. Connection - video-interface and external keypad
- 2.10. Picture settings

3. Interface operation

- 3.1. By factory touch screen
- 3.2. By keypad

4. Specifications

5. FAQ – Trouble Shooting-Interface functions

6. Technical support

Legal Information

By law, watching moving pictures while driving is prohibited, the driver must not be distracted. We do not accept any liability for material damage or personal injury resulting, directly or indirectly, from installation or operation of this product. Apart from using this product in an unmoved vehicle, it should only be used to display fixed menus or rear-view-camera video when the vehicle is moving (for example the MP3 menu for DVD upgrades).

Changes/updates of the vehicle's software can cause malfunctions of the interface. Up to one year after purchase we offer free software-updates for our interfaces. To receive a free update, the interface has to be sent in at own cost. Wages for de- and reinstallation and other expenditures involved with the software-updates will not be refunded.

1. Prior to installation

Read the manual prior to installation. Technical knowledge is necessary for installation. The video interface's place of installation must be free of moisture and away from heat sources.

Before the final installation in the vehicle of the video sources, we recommend a test-run to ensure the compatibility of vehicle and interface. Due to changes in the production of the vehicle manufacturer there's always a possibility of incompatibility.

1.1. Delivery contents

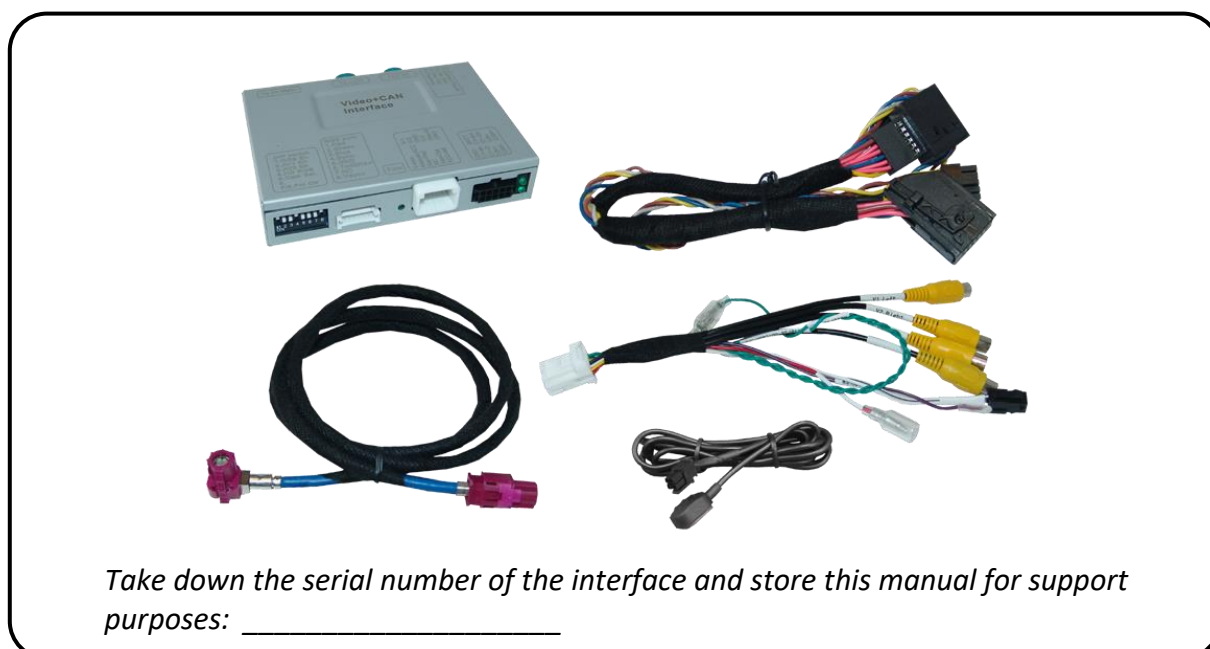

1.2. Checking the compatibility of vehicle and accessories

Requirements

Brand	Compatible vehicles	Compatible systems
Land Rover	Range Rover since model year 2018 Range Rover Sport since model year 2018 Range Rover Velar since model year 2017 Range Rover Evoque since model year 2020 Discovery 5	Incontrol Touch Pro Duo with 10.2 inch 24:9 monitor (glossy) and climate control panel via 2nd touch monitor
Jaguar	XE since model year 2019 I-Pace since model year 2019	

Limitations

<i>Video only</i>	The interface inserts ONLY video signals into the infotainment. For inserting Audio signals either the possibly existing factory audio-AUX-input or a FM-modulator can be used. If 2 audio sources shall be connected to the infotainment, an additional electronic is necessary to switch them.
<i>Factory rear-view camera</i>	Automatically switching-back from inserted video to factory rear-view camera is only possible while the reverse gear is engaged. To delay the switch-back an additional electronic part is required.
<i>After market front camera</i>	The front camera will automatically be switched for 10 seconds after disengaging the reverse gear. A manually front camera switching is possible by external keypad.
<i>PDC and guide lines</i>	If the video interface does not receive the required information from the vehicle CAN-bus, neither guide-lines nor optical PDC display will be supported.
<i>Video input signal</i>	only NTSC compatible

1.3. Connection video interface

The video-interface converts the video signals of connected after-market sources in a factory monitor compatible picture signal which is inserted in the factory monitor, by using separate trigger options. Further it reads the vehicle's digital signals out of the vehicle's CAN-bus and converts them for the video interface.

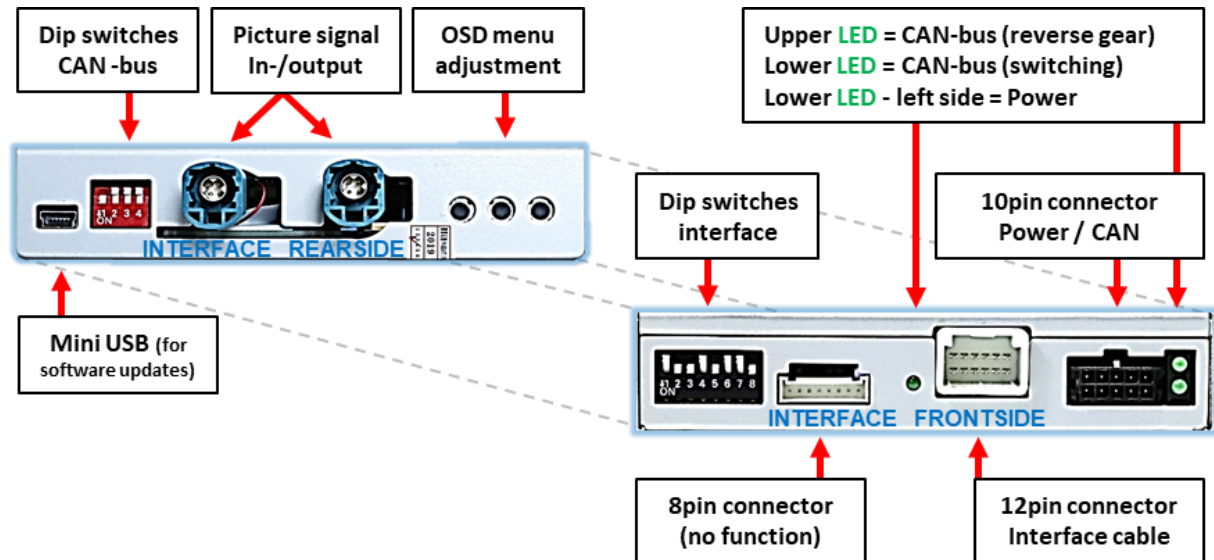

1.4. Settings of the 8 Dip switches (black)

Some settings have to be selected by the dip-switches on the video interface.

Dip position **down = ON** and position **up = OFF**.



Dip	Function	ON (down)	OFF (up)
1	Front camera	enabled*	disabled
	Power supply output (red wire)	+12V (max. 3A) when reverse gear is engaged incl. 10 seconds delay and +12V by manual switching to front camera by keypad	+12V (max. 3A) ACC
2	CVBS AV1-input	enabled	disabled
3	CVBS AV2-input	enabled	disabled
4	No function		Set to OFF
5	Rear-view cam type	after-market	factory or none
6	Guide lines	enabled	disabled
7	PDC	enabled	disabled
8	No function		Set to OFF

*The front camera will automatically be switched for 10 seconds after disengaging the reverse gear.

See the following chapters for detailed information.

After each Dip-switch-change a power-reset of the Can-box has to be performed!

1.4.1. Activating the front camera input (dip 1)

If set to ON, the interface switches for 10 seconds from the rear-view camera to the front camera input after having disengaged the reverse gear. In addition, a manual switch-over to the front camera input is possible via keypad (short press) from any image mode.

Description of the front camera power supply: see chapter "Power supply output".

1.4.2. Enabling the interface's video inputs (dip 2-3)

Only the enabled video inputs can be accessed when switching through the interface's video sources. It is recommended to enable only the required inputs, disabled inputs will be skipped when switching through the video-interfaces inputs.

1.4.3. Rear-view camera setting (dip 5)

If set to OFF, the interface switches to factory picture while the reverse gear is engaged to display factory rear-view camera.

If set to ON, the interface switches to its rear-view camera input „ V4 Reverse “ while the reverse gear is engaged.

1.4.4. Enabling the Guide lines (dip 6)

If set to ON, the interface is activated to show the guide lines for the rear-view camera while the vehicle is in reverse mode (not available for all vehicles).



Note: Some vehicles have a different code on the CAN-bus which the video-interface is not compatible with. If the interface does not completely communicate with the vehicle CAN bus, the reverse gear guide-lines can't be shown during the vehicle's operation, even if they in some vehicles once appear after having switched the system to powerless!

1.4.5. Activating the PDC (dip7)

If set to ON, the PDC car will be displayed on the screen and the park distance will be shown by using the signals of the vehicle's CAN-bus. If there is no communication between the interface and the vehicle's CAN-bus (several vehicles aren't compatible), the park distance can't be shown. In this case, set dip7 to OFF.

Note: Dip 4 and 8 are out of function and have to be set to **OFF!**

1.5. Settings of the 4 Dip switches (CAN functions – red)

All 4 dip-switches of the video interface have no function for normal use and have to be set to OFF.

Dip position “down” is ON and position up is OFF.



Navigation / system	Dip 1	Dip 2	Dip 3	Dip 4
Range Rover, Range Rover Sport, Discovery 5, Range Rover Velar, New Jaguar XE	ON	OFF	OFF	OFF
Jaguar XF protocol	OFF	ON	OFF	OFF
Jaguar XE 2016 protocol	OFF	OFF	OFF	OFF

If the CAN communication doesn't succeed with the mentioned CAN positions, the other CAN protocol can also be tried.

After each Dip-switch-change a power-reset of the video interface has to be performed!

2. Installation

To install the interface, first switch off the ignition and disconnect the vehicle's battery. Please read the owner's manual of the car, regarding the battery's disconnection! If required, enable the car's Sleep-mode (hibernation mode)

In case the sleep-mode does not succeed, the disconnection of the battery can be done with a resistor lead.

If the necessary stabilized power supply for the interface is not taken directly from the battery, the chosen connection has to be checked for being constantly stable.

The interface needs a permanent 12V source!

2.1. Place of installation

The video interface is supposed to be installed at a suitable location behind the factory monitor. This requires the vehicle's centre console to be removed.

2.2. Monitor removal – example Land Rover



1

Remove both sides of the middle console panelling.



2

Turn out these five screws on both sides of the frame behind the side panelling.



3

Turn out this screw on both sides at the top of the frame.



4

Carefully, remove the frame.



5

Carefully, remove this plastic panelling below the instruments.



6

Turn out the screws which fix the monitor part.

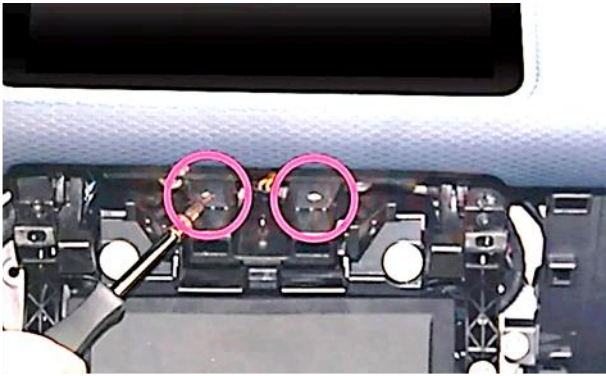

7 Turn out these screws below the trim panel.



8 Remove this plastic cover on the right side of the trim panel.

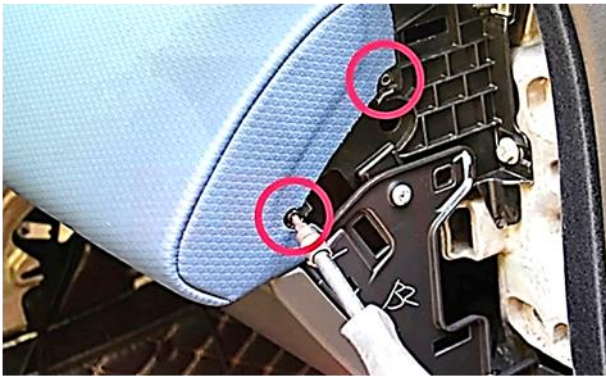

9 Turn out the screws on the right side of the trim panel.



10 Carefully remove the trim panel to allow the monitor's removal.

2.3. Note for test run

In vehicles in which the climate control system is operated by the touchscreen monitor, it is necessary to have the monitor connected for an interface test run.
(Concerns e.g. all Land Rover and some other vehicles)

2.4. Connection schema

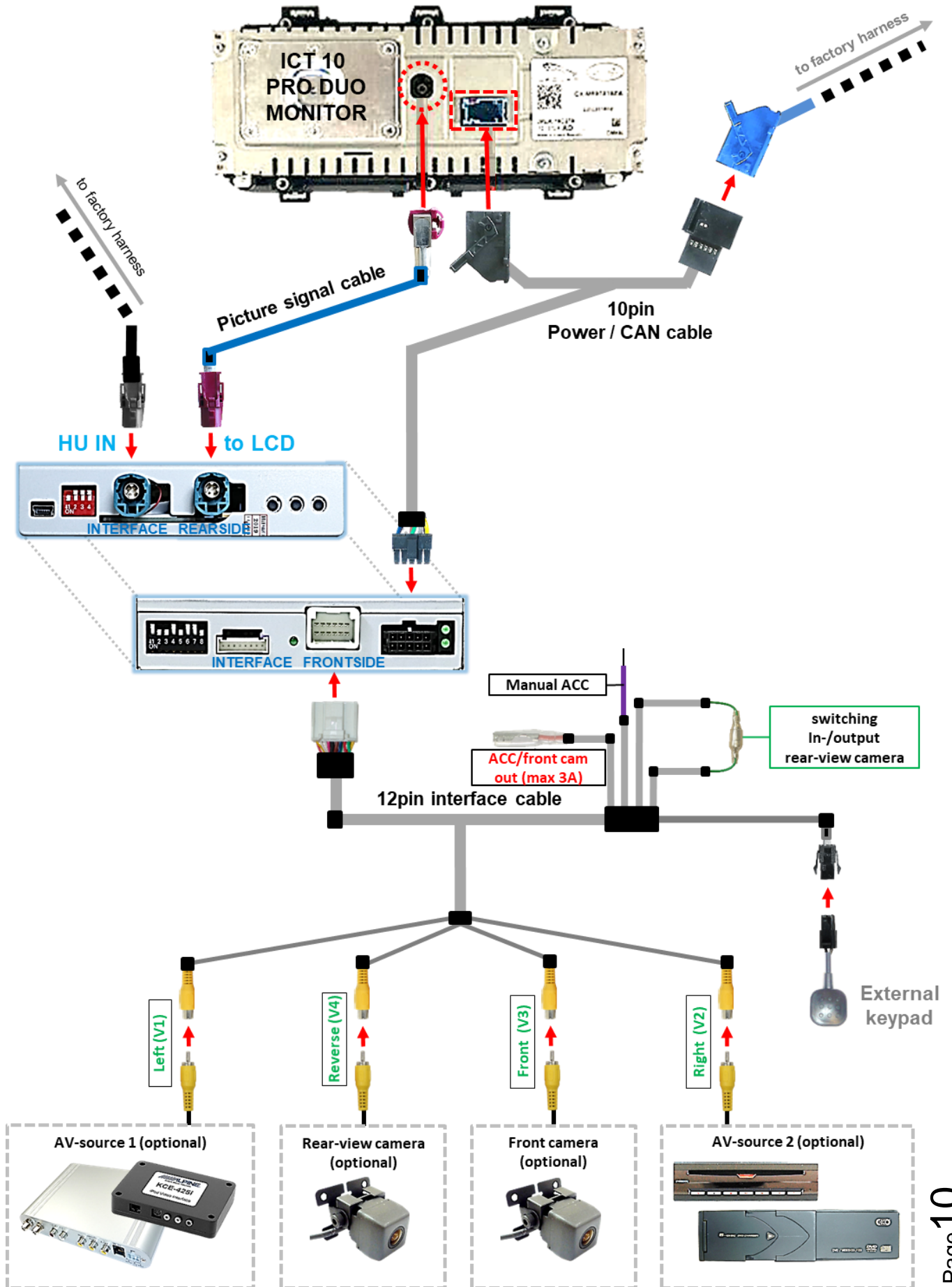

2.5. Connection – picture signal cable

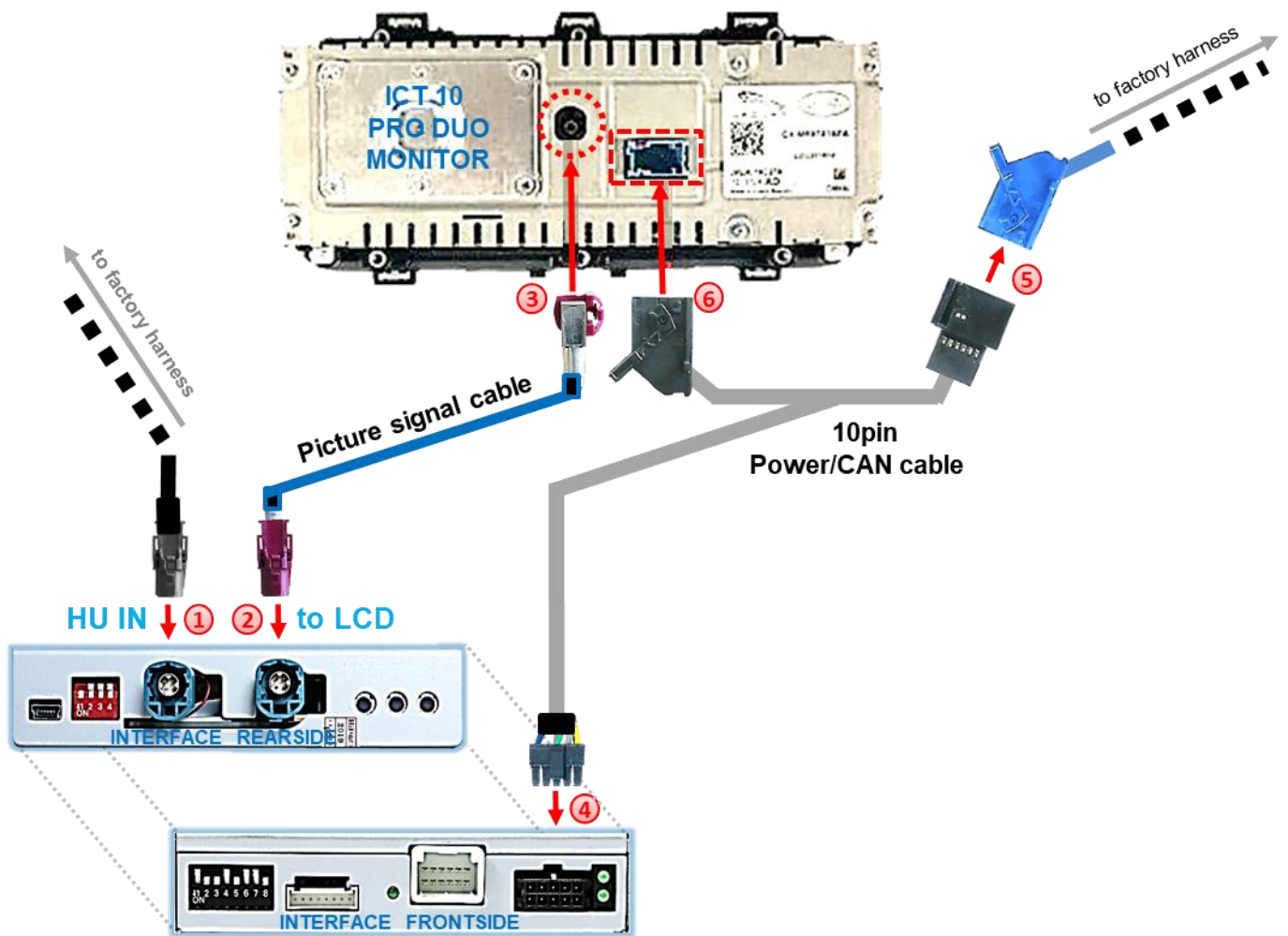

- ① Disconnect the female HSD connector of the vehicle harness from the rear-side of the factory monitor and connect it to the waterblue coloured HSD connector **"HU IN"** of the video interface.
- ② Connect the not-angled female HSD connector of the enclosed picture signal cable to the video interfaces' HSD connector **"TO LCD"**.
- ③ Connect the opposite angled female HSD connector of the enclosed picture signal cable to the previously become free male 4pin HSD connector of the factory monitor
- ④ Connect the 10pin Power/CAN cable's female 10pin connector to the 10pin connector of the video interface.
- ⑤ Disconnect the female 12-Pin AMP locking connector of the vehicle harness from the rear of the factory monitor and connect it to the male 12-Pin AMP connector of the 10pin Power/CAN cable.
- ⑥ Connect the 10pin Power/CAN cable's female 12pin AMP locking connector to the previously become free 12pin AMP connector of the monitor.

Note: The colours of the HSD connectors at monitor and head unit may vary. The picture signal cable's connecting direction doesn't have an impact on the system's function, for that the angled and not-angled HSD connectors are allowed to be interchanged, depending on the HSD connectors mounting space at the monitor.



However, mixing up/interchanging the connections of „HU IN“ and „TO LCD“ may cause dysfunction or even damage to the system!

After the connections of the video interface have been done, carry out the following technical checks:

Check 1

Exceptionally, the CAN communication may not succeed in all vehicles! If, after connecting the PNP harness, no interface LED lightens up while the ignition is turned on, additionally the analog power supply needs to be done! (see following chapter)

Check 2

Exceptionally, the power supply to the video interfaces may not be interrupted after switching to the vehicle's sleep mode. If the interface LEDs continue to shine even in the vehicle's sleep mode, please contact the support!

2.6. Analog power supply for the video interface

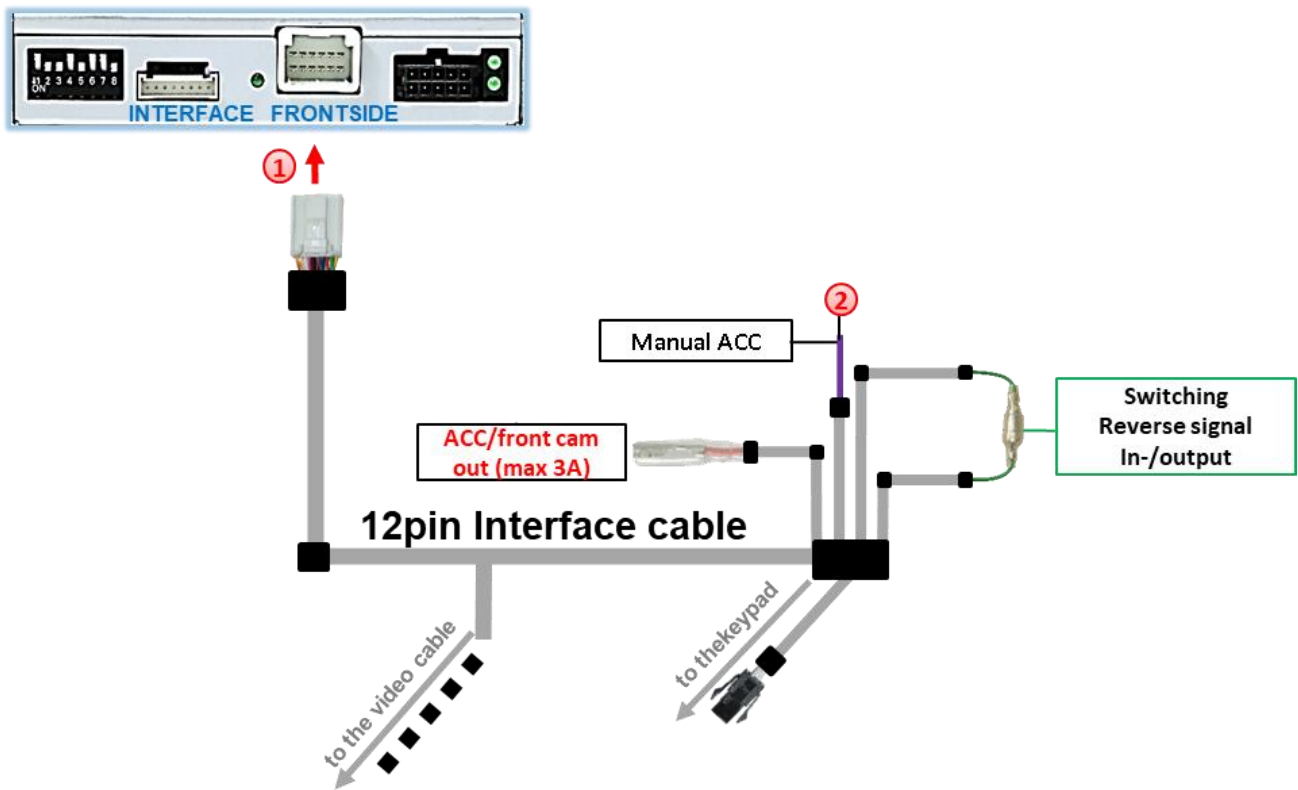

- ① If, after connecting the PNP harness, no interface LED lightens up while the ignition is turned on, the purple coloured wire **Manual ACC** of the 12pin interface cable has to be connected additionally to **S-contact terminal 86s +12V** (e.g. glove compartment illumination).

2.7. Power supply output

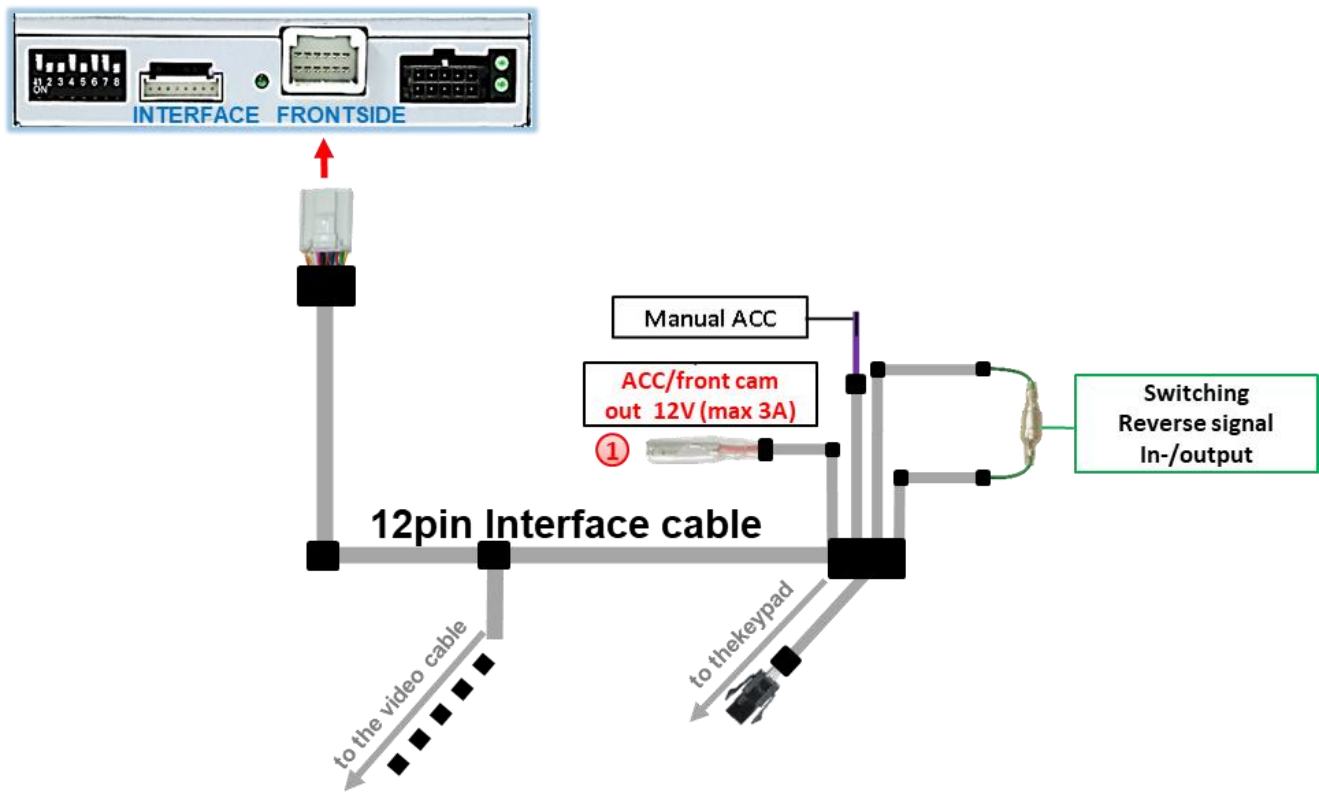

① The red power supply output **ACC/front cam out 12V (max 3A)** can be used to power an external source and has a different assignment, depending on the position of dip switch 1 (of 8 daps):

Dip	Function
Dip 1 ON	+12V (max. 3A) when reverse gear is engaged plus 10 seconds delay after reverse gear is disengaged and +12V when manually switched to front camera by keypad (short press)
Dip 1 OFF	+12V permanent (max. 3A) ACC

2.8. Connection - video sources

It is possible to connect an after-market rear-view camera, an after-market front camera and two more video sources to the video-interface.

Before a final installation of the video sources, we recommend a test-run to ensure the compatibility of vehicle and interface. Due to changes in the production of the vehicle manufacturer there's always a possibility of incompatibility.

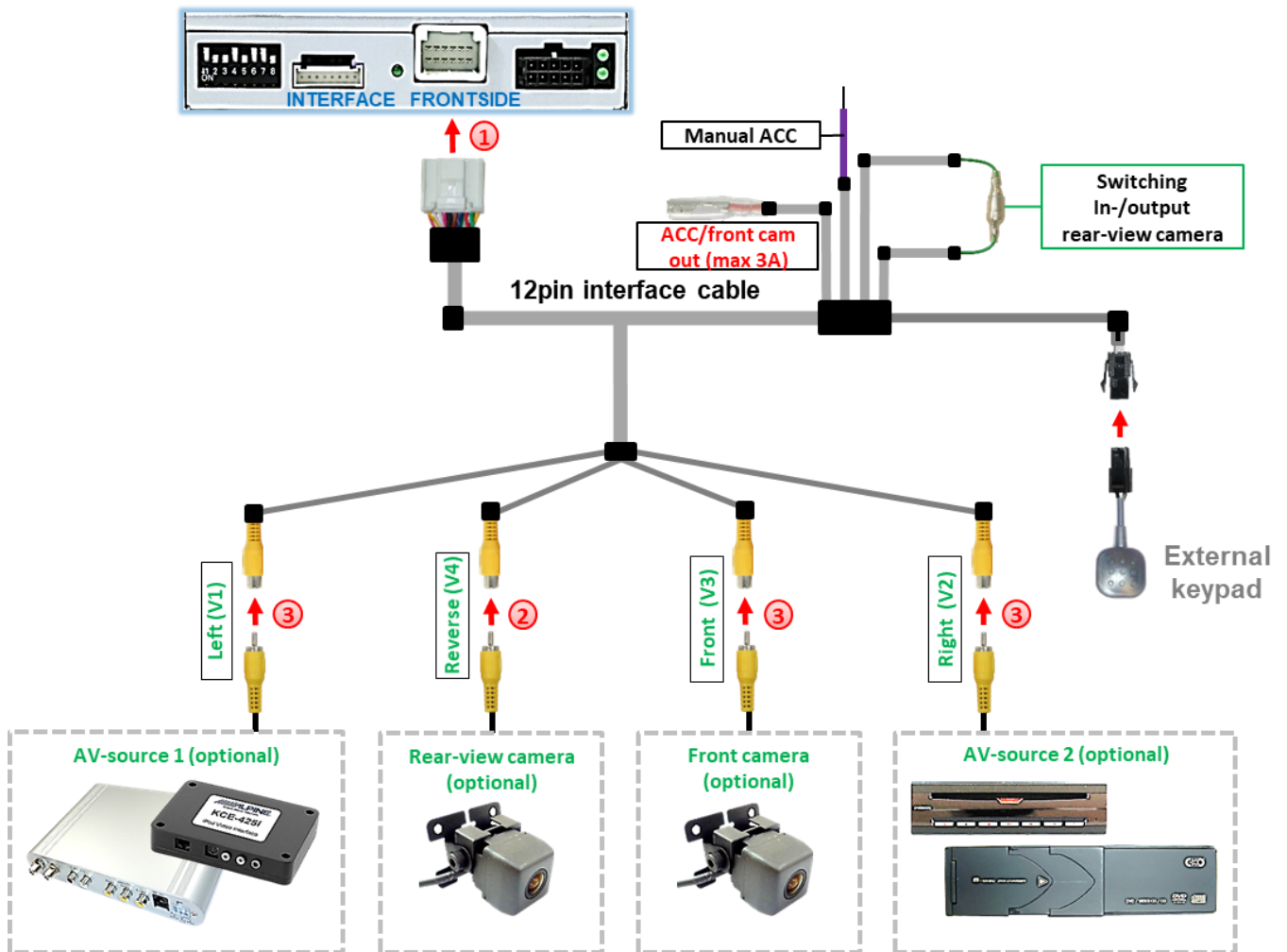

- ① Connect the female 12pin connector of the 12pin interface cable to the male 12pin connector of the video-interface.
- ② Connect the video RCA of the Rear-view camera to the female RCA connector **“Reverse (V4)”** of the 12pin interface cable.
(refer also to chapter “after-market rear-view camera”).
- ③ Connect the video RCA of the front camera to the female RCA connector **“Front (V3)”** of the 12pin interface cable.
(refer also to chapter “After-market front camera”).
- ④ Connect the video RCA of the video source 1 and 2 to the female RCA connector **„Left (V1)”** and **„Right (V2)”** of the 12pin interface cable.

2.8.1. Audio-insertion

This interface is only able to insert video signals into the factory infotainment. If an AV-source is connected, the audio insertion has to be done by the factory audio AUX input or an FM-modulator. The inserted video-signal can be activated simultaneously to each audio-mode of the factory infotainment. If 2 AV sources shall be connected to the infotainment, additional electronic is necessary to switch the audio signals.

2.8.2. After-market front camera

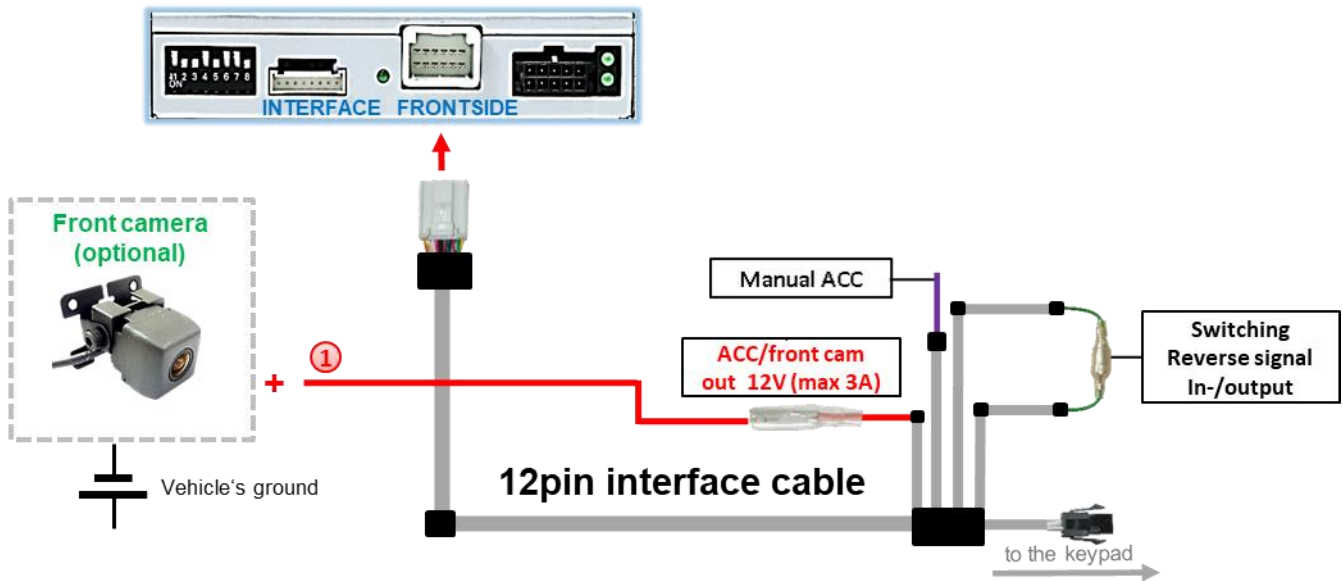

- ① The red power supply output **ACC/front cam out 12V (max 3A)** can be used to power a front camera. If Dip 1 is set to ON (black 8 dips), the power supply output gives +12V (max 3A) when reverse gear is engaged plus 10 seconds delay after reverse gear is disengaged.

Note: In addition, a manual switch-over to the front camera input is possible via keypad (short press) from any image mode. The power supply output gives +12V then, as well (if Dip 1 is set to ON and the front camera input is selected).

Attention: A long press of the external keypad push button will switch the interface to the next source.

2.8.3. After-market rear-view camera

Some vehicles have a different reverse gear code on the CAN-bus which the video-interface is not compatible with. Therefore, there are two different ways of installation. If the video interface receives a signal of the reverse gear, the green wire “Reverse-OUT” of the 20pin cable should carry +12V while the reverse gear is engaged.

Note: Do not forget to set video interface’s dip5 to ON before testing.

2.8.3.1. Case 1: Interface receives the reverse gear signal

If the interface delivers +12V on the green output wire of the 12pin interface cable while reverse gear is engaged, the video interface will automatically switch to the rear-view camera input „Reverse (V4)“ while the reverse gear is engaged.

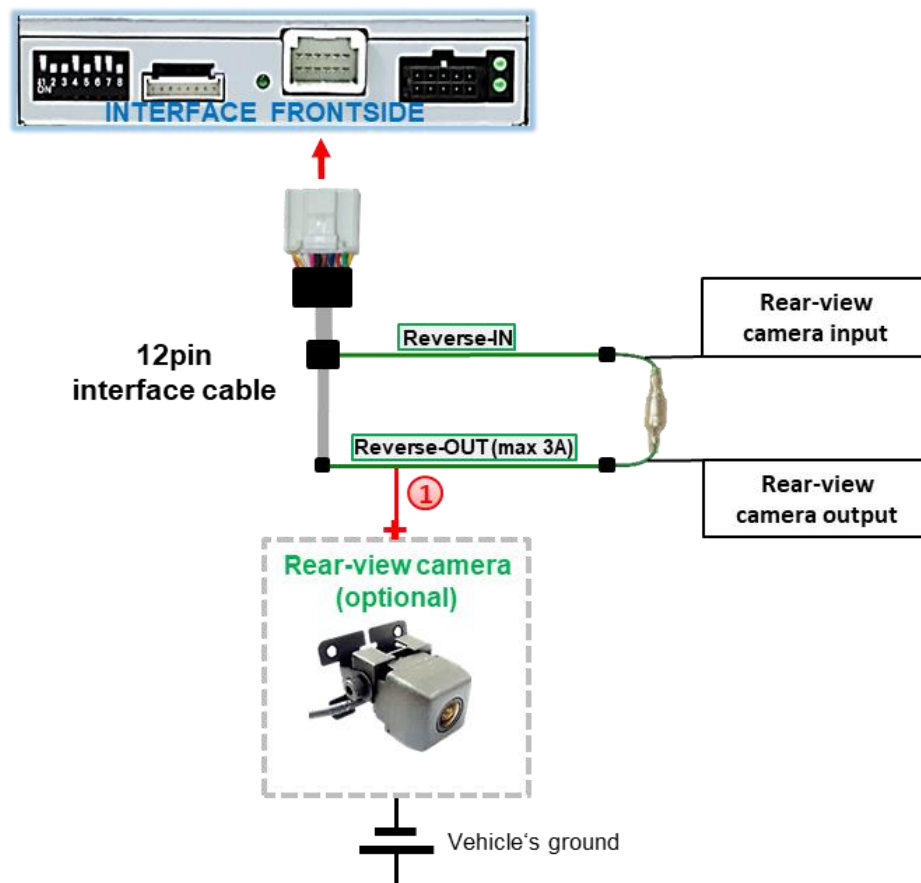

- ① Additionally, the +12V (max. 3A) power supply for the rear-view camera can be taken from the green wire of the 12pin interface cable.

2.8.3.2. Case 2: Interface does not receive the reverse gear signal

If the video interface does not deliver +12V on the green wire of the 12pin cable when reverse gear is engaged (not all vehicles are compatible), an external switching signal from the reverse gear light is required. As the reverse gear light's power supply isn't voltage-stable all the time, an ordinary open relay (e.g AC-RW-1230 with wiring AC-RS5) or filter (e.g. AC-PNF-RVC) is required. The diagram below shows the connection type of the relay.

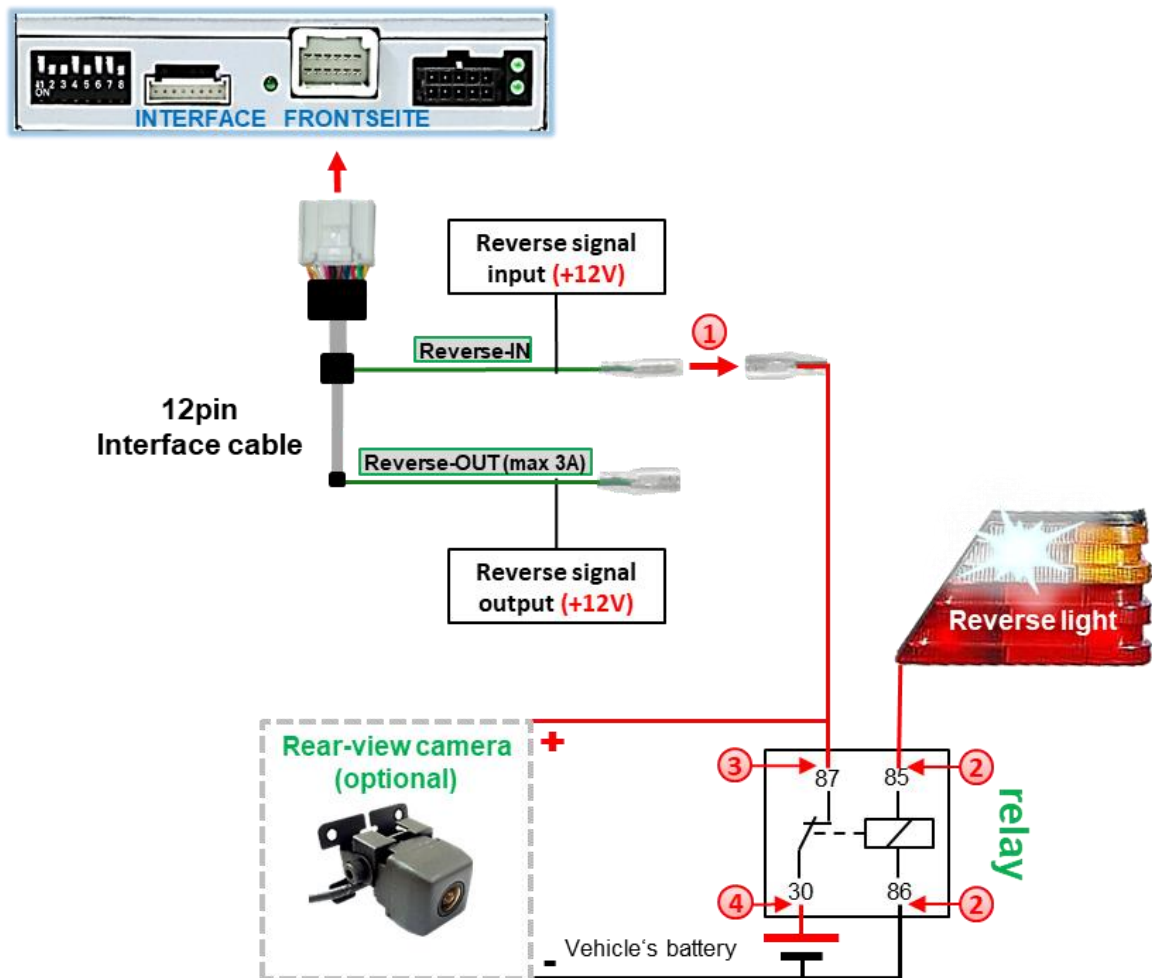

- ① Disconnect the green cable's preconnected male- and female connectors of the 12pin cable and connect the green input cable "Reverse-IN" to the output connector (87) of the relay.

Note: To avoid short circuits, the best solution should be, to crimp a male 4mm connector to the relay's output cable and connect it to the green cable's female 4mm connector. The output-cable "Reverse-OUT" remains disconnected as it's out of function.

- ② Connect the Reverse light's power-cable to coil (85) and the vehicle's ground to coil (86) of the relay.
- ③ Connect the output connector (87) of the relay to the rear-view camera's power-cable, like you did it to the green "Reverse-IN" cable before.
- ④ Connect stable and permanent +12V to the relay's input connector (30).

2.9. Connection - video-interface and external keypad

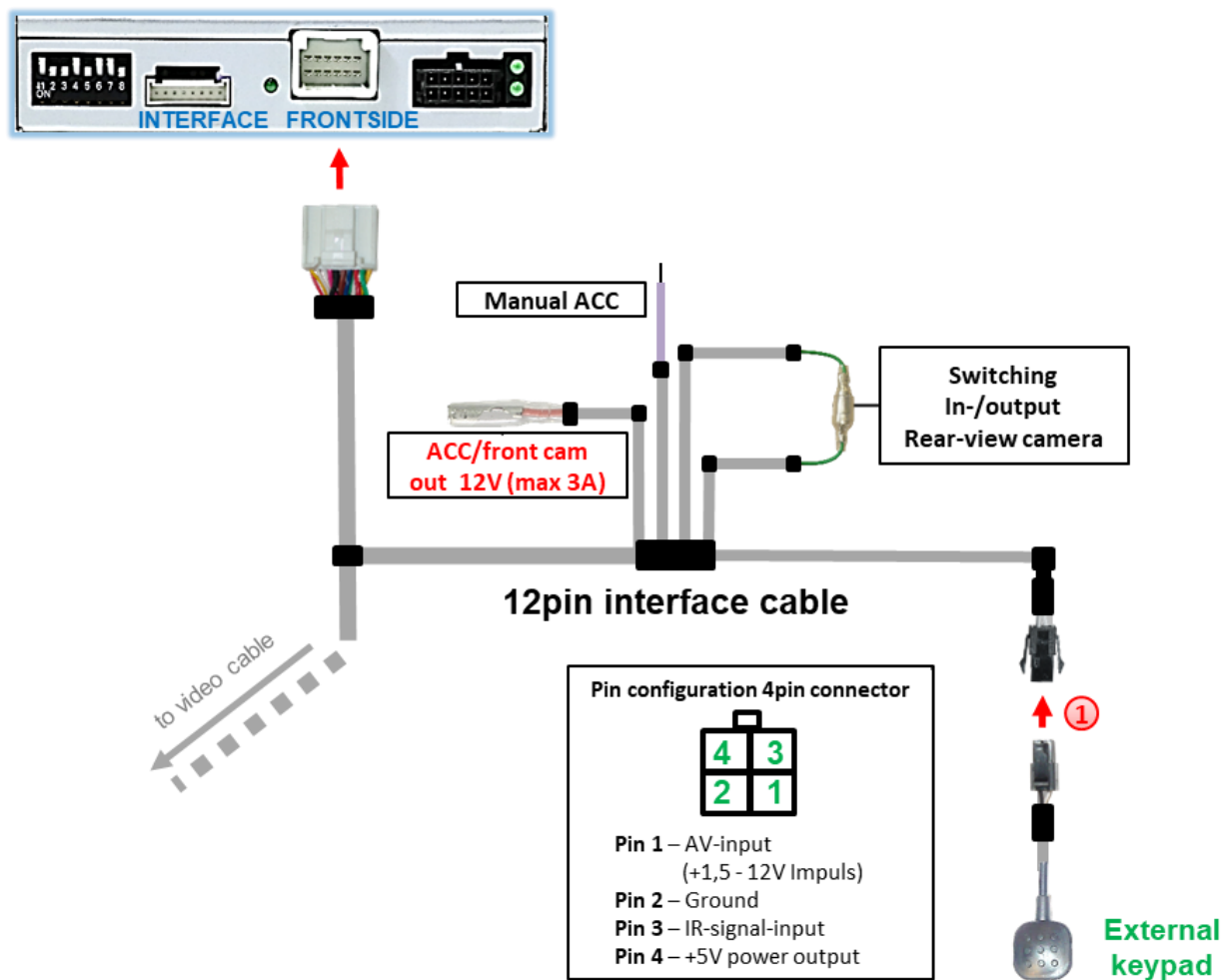

- ① Connect the female 4pin connector of the keypad to the male 4pin connector of the 12pin interface cable.

Note: Even if switching through several video sources by the keypad mightn't be required, the invisible connection and availability is strongly recommended.

2.10. Picture settings

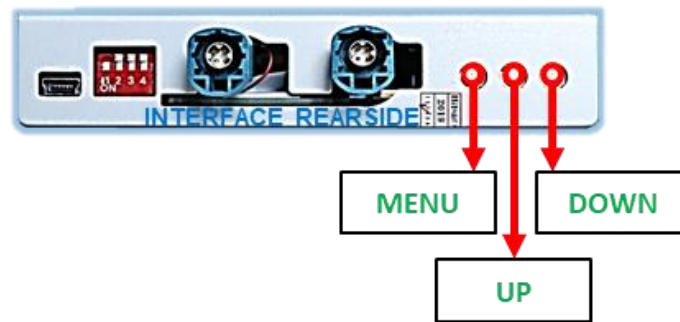

The picture settings are adjustable by the 3 push-buttons on the video-interface. Press the MENU button to open the OSD settings menu or to switch to the next menu item. Press UP and DOWN to change the selected value. The buttons are placed inside in the housing to avoid accidental changes during or after the installation. Picture settings must be done separately for Video1, Video2 and Camera while the corresponding input is selected and visible on the monitor.

Note: The OSD menu is only shown when a working video source is connected to the selected video-input of the interface.

The following settings are available:

- Contrast
- Brightness
- Saturation
- Position H (no function)
- Position V (no function)
- IR-AV1/2 (no function)
- Guide L/R (no function)
- Guide-CNTRL (no function) (Dip switch 6) -
- Size H/V (no function)

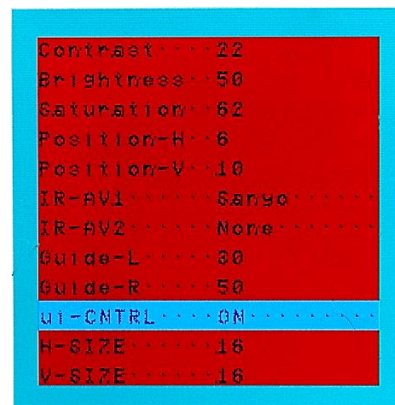

3. Interface operation

3.1. By factory touch screen

To switch the interface's activated video sources, the factory touch screen can be used.

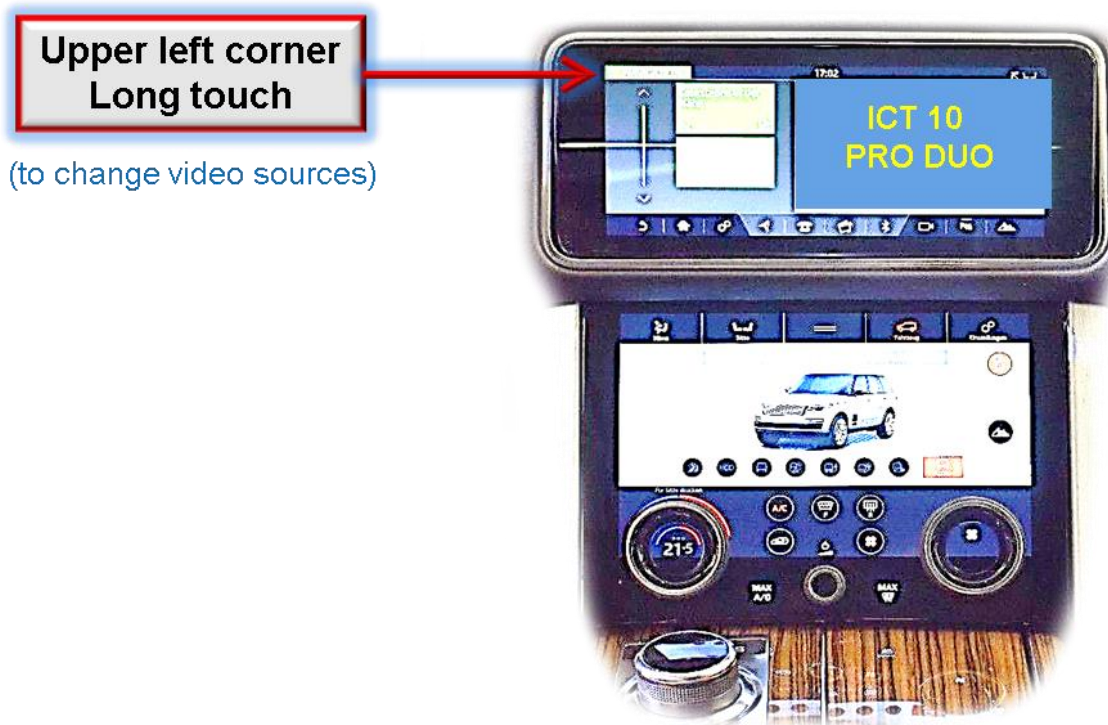

Make a long touch of the left top corner of the factory touch screen to switch the video-source.

Long pressing the left top corner of the factory touch screen switches the input from the factory video to the inserted video sources. If all inputs are activated by dip switch settings, the order is the following:

Factory video → Video IN 1 → Video IN 2 → factory video

Each press will switch to the next enabled input. Inputs which are not enabled will be skipped.

Switchover by factory touch screen isn't possible in all vehicles. In some vehicles the external keypad has to be used.

3.2. By keypad

Alternatively or additionally to the factory infotainment buttons, the interface's external keypad can be used to switch the enabled inputs. Even if not needed, the keypad should always remain connected to the video interface for support purposes. (see next page).

➤ Long press of keypad (2-3 seconds)

By long pressing the external keypad (2-3 seconds), the video interfaces switches the input from the factory video to the inserted video sources.

Each press (approx. 2 sec) will switch to the next enabled input. If all inputs are enabled the order is:

Factory video → video IN1 → video IN2 → factory video →...

Disabled inputs will be skipped.

Note: The interface switches **after releasing** the switch (after long pressure).

➤ Short press of keypad (only if DIP 1 is set to ON)

By short pressing the external keypad, the video interfaces switches from the factory video to the front camera input and back to factory video.

4. Specifications

BATT/ACC range	7V - 25V
Stand-by power drain	6mA
Power	180mA @12V
Video input	0.7V - 1V
Video input formats	NTSC
Temperature range	-40°C to +85°C
Dimensions video-box	117 x 25 x 104 mm (W x H x D)

5. FAQ – Trouble shooting Interface functions

For any troubles which may occur, check the following table for a solution before requesting support from your vendor.

Symptom	Reason	Possible solution
No picture/black picture (factory picture).	Not all connectors have been reconnected to factory head-unit or monitor after installation.	Connect missing connectors.
	No power on CAN-bus box (all LED CAN-bus box are off).	Check power supply of CAN-bus box. Check CAN-bus connection of CAN-bus box.
	CAN-bus box connected to CAN-bus in wrong place.	Refer to the manual where to connected to the CAN-bus. If not mentioned, try another place to connect to the CAN-bus.
	No power on video-interface (all LED video-interface are off).	Check whether CAN-bus box delivers +12V ACC on red wire output of 8pin to 6pin cable. If not cut wire and supply ACC +12V directly to video-interface.
No picture/black picture/white picture (inserted picture) but factory picture is OK.	No picture from video source.	Check on other monitor whether video source is OK.
	No video-source connected to the selected interface input.	Check settings dips 1 to 3 of video interface which inputs are activated and switch to corresponding input(s).
	LVDS cables plugged in wrong place.	Double-check whether order of LVDS cables is exactly connected according to manual. Plugging into head-unit does not work when the manual says to plug into monitor and vice versa.
Inserted picture totally wrong size or position.	Wrong monitor settings of video-interface.	Try different combinations of dips 7 and 8 of video-interface. Unplug 6pin power after each change.
Inserted picture double or 4 times on monitor.		
Inserted picture distorted, flickering or running vertically.	Video sources output set to AUTO or MULTI which causes a conflict with the interfaces auto detection.	Set video source output fixed to PAL or NTSC. It is best to set all video sources to the same standard.
	If error occurs only after source switching: Connected sources are not set to the same TV standard.	Set all video sources to the same standard.
	Some interfaces can only handle NTSC input.	Check manual whether there is a limitation to NTSC mentioned. If yes, set source fixed to NTSC output.
Inserted picture b/w.	Picture settings have not been adjusted.	Use the 3 buttons and the interface's OSD to adjust the picture settings for the corresponding video input.
Inserted picture qual. bad.		
Inserted picture size slightly wrong.		
Inserted picture position wrong.		
Camera input picture flickers.	Camera is being tested under fluorescent light which shines directly into the camera.	Test camera under natural light outside the garage.
Camera input picture is bluish.	Protection sticker not removed from camera lens.	Remove protection sticker from lens.

Symptom	Reason	Possible solution
Camera input picture black.	Camera power taken directly from reverse gear lamp.	Use relay or electronics to "clean" reverse gear lamp power. Alternatively, if CAN-bus box is compatible with the vehicle, camera power can be taken from green wire of 6pin to 8pin cable.
Camera input picture has distortion.		
Camera input picture settings cannot be adjusted.	Camera input picture settings can only be adjusted in AV2 mode.	Set dip 3 of video-interface to ON (if not input AV2 is not already activated) and connect the camera to AV2. Switch to AV2 and adjust settings. Reconnect camera to camera input and deactivate AV2 if not used for other source.
Graphics of a car in camera input picture.	Function PDC is ON in the interface OSD.	In compatible vehicles, the graphics will display the factory PDC distance. If not working or not wanted, set interface OSD menu item UI-CNTRL to ALLOFF.
Chinese signs in camera input picture	Function RET or ALL is ON (function for Asian market) in the interface OSD.	Set interface OSD menu item UI-CNTRL to ALLOFF or PDCON.
Not possible to switch video sources by OEM button.	CAN-bus interface does not support this function for vehicle.	Use external keypad or cut white wire of 6pin to 8pin cable and apply +12V impulses for AV-switching.
Not possible to switch video sources by external keypad.	Pressed too short.	For video source switching a longer press of about 2.5 seconds is required.
	SW-version of interface does not support external keypad.	Use OEM-button or cut white wire of 6pin to 8pin cable and apply +12V impulses for AV-switching.
Interface does not switch to camera input when reverse gear is engaged.	CAN-bus interface does not support this function for the vehicles.	Cut the green wire of the 6pin to 8pin cable and apply +12V constant from reverse gear-lamp signal. Use relay to "clean" R-gear lamp power.
Interface switches video-sources by itself.	CAN-bus interface compatibility to vehicle is limited.	Cut the grey wire of 6pin to 8pin and isolate both ends. If problem still occurs, additionally cut the white wire of 6pin to 8pin cable and isolate both ends.

6. Technical Support

Please note that direct technical support is only available for products purchased directly from NavLinkz GmbH. For products bought from other sources, contact your vendor for technical support.

NavLinkz GmbH
distribution/tech dealer-support
 Heidberghof 2
 D-47495 Rheinberg

Tel +49 2843 17595 00
 Email mail@navlinkz.de

 10R-05 0068

Made in China

