

Video-inserter RL4-NAC

Attention!
*Do not connect to vehicle monitor
Damage to hardware!*



**Compatible with
Opel, Citroen, Peugeot and Toyota vehicles
with NAC or RCC infotainment
and 7inch or 8inch monitor**

**Video-inserter for front- and rear-view camera
and two additional video inputs**

Attention!
*Only for vehicles
with 7 inch or 8 inch monitors
(For 10.25 inch monitors
use RL4-NAC12)*

Product features

- Video-inserter for factory-infotainment systems
- 1 CVBS Input for rear-view camera
- 1 CVBS Input for front camera
- 2 CVBS video-inputs for after-market devices (e.g. USB-Player, DVB-T2 tuner)
- Automatic switching to rear-view camera input on engagement of the reverse gear
- Automatic front camera switching after reverse gear for 10 seconds
- Activatable parking guide lines for the rear-view camera (not available for all vehicles)
- Activatable PDC (not available for all vehicles)
- Video-in-motion (ONLY for connected video-sources)
- Video-inputs NTSC compatible

Contents

1. Prior to installation

- 1.1. Delivery contents
- 1.2. Checking the compatibility of vehicle and accessories
- 1.3. Warning notes
- 1.4. Connection Video-Interface
- 1.5. Settings of the 8 Dip switches (black)
 - 1.5.1. Adjustment – power supply output (dip 1)
 - 1.5.2. Enabling the interface's video inputs (dip 2-3)
 - 1.5.3. Rear-view camera setting (dip 5)
 - 1.5.4. Activating – front camera back switching (dip 6)
 - 1.5.5. Choosing the corresponding head unit version (dip 8)
- 1.6. Settings of the 4 Dip switches (CAN function – red)

2. Installation

- 2.1. Place of installation – video interface
- 2.2. Connection schema
- 2.3. Connection - head-unit
 - 2.3.1. Connection – picture signal cable
 - 2.3.1.1. High version head unit (2 x 4 PIN HSD)
 - 2.3.1.2. Low version head unit (1 x 4 PIN HSD)
 - 2.3.2. Connection– Power / CAN
 - 2.3.3. Analog power supply for the video interface
- 2.4. Power supply output
- 2.5. Connection - video sources
 - 2.5.1. Audio insertion
 - 2.5.2. After-market front camera
 - 2.5.3. After-market rear-view camera
 - 2.5.3.1. Case 1: Video-interface receives the reverse gear signal
 - 2.5.3.2. Case 2: Video interface does not receive the reverse gear signal
- 2.6. Connection - external keypad
- 2.7. Picture settings and guide lines

3. Interface operation

- 3.1. By NAVI button
- 3.2. By external keypad

4. Specifications

5. FAQ – Trouble shooting

6. Technical support

Legal Information

By law, watching moving pictures while driving is prohibited, the driver must not be distracted. We do not accept any liability for material damage or personal injury resulting, directly or indirectly, from installation or operation of this product. Apart from using this product in an unmoved vehicle, it should only be used to display fixed menus or rear-view-camera video when the vehicle is moving (for example the MP3 menu for DVD upgrades).

Changes/updates of the vehicle's software can cause malfunctions of the interface. Up to one year after purchase we offer free software-updates for our interfaces. To receive a free update, the interface has to be sent in at own cost. Wages for de-and reinstallation and other expenditures involved with the software-updates will not be refunded.

1. Prior to installation

Read the manual prior to installation. Technical knowledge is necessary for installation. The place of installation must be free of moisture and away from heat sources.

1.1. Delivery contents



Take down the serial number of the interface and store this manual for support purposes: _____

1.3. Warning notes:

Damage to the head-unit is possible, if this RL4-NAC interface is installed to older Citroen / Peugeot SMEG or SMEG+ head-units (by Magneti Marelli)! Use this RL4-NAC interface only on Citroen/Opel/Peugeot/Toyota head-units NAC (by Continental) or RCC (Bosch). Designs and features – see the following pictures:



NAC-Systems

Furthermore, even when installed to the correct NAC systems, there is also **damage** to the head-unit possible if:

- the 4pin HSD connectors of this harness are wrong-plugged
- the 4pin HSD harness is connected to the vehicle monitor

Attention!
Do not connect to vehicle monitor
Damage to hardware!

Prior to installation, the head-unit's version has to be determined (see following page).

1.4. Checking the head unit's version

Prior to installation, it has to be determined if whether the head-units version is a

low version head-unit

(single black male 4pin
HSD on backside)



Attention: Bosch Low Version requires different Dip 8 switch position (see following chapters)

OR

high version head-unit

(double black male 4pin
HSD on the backside)



Please, carefully follow the manual for high or low version connection of the head unit and the assignment of the Dip-8 switch position!

1.5. Connectors - Video-Interface

The video-interface converts the video signals of connected after-market sources in a factory monitor compatible picture signal which is inserted in the factory monitor, by using separate trigger options. Further it reads the vehicle's digital signals out of the vehicle's CAN-bus and converts them for the video interface.

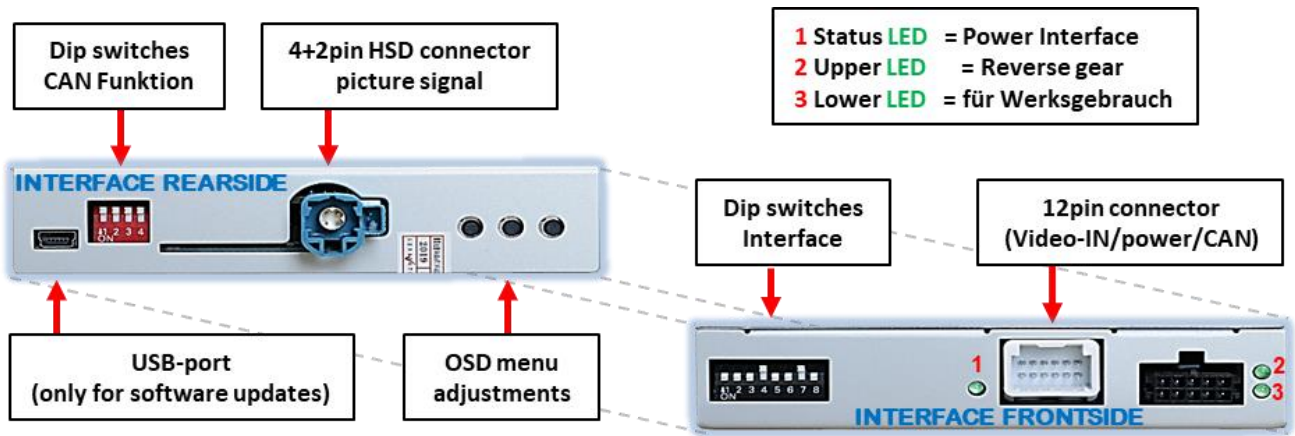

1.6. Settings of the 8 Dip switches (black)

Some settings have to be selected by the 8 dip-switches at the video-interface. Dip position down is ON and position up is OFF.



Dip	Function	ON (down)	OFF (up)
1	Power supply output (red wire)	+12V (max. 3A) when reverse gear is engaged incl. 10 seconds delay and +12V by manual switching to front camera by keypad	+12V (max. 3A) ACC
2	CVBS AV1-input	enabled	disabled
3	CVBS AV2-input	enabled	disabled
4	No function		Set to OFF
5	Rear-view cam type	after-market	factory or none
6	Frontcam back-switching for 10 seconds	enabled	disabled
7	No function		Set to OFF
8	Monitor type	Low resolution monitor	High resolution monitor

If you do not know the resolution, test both settings.
Power reset after change of dip switches necessary.

See the following chapters for detailed information.

After each Dip-switch-change a power-reset of the Interface-box has to be performed!

1.6.1. Adjustment – power supply output (dip 1)

If set to **ON**, the video interfaces' red wire will supply +12V (max 3A) with engaging the reverse gear and additionally 10 more seconds delay for the time of the front camera's back-switching after the reverse gear has been disengaged. Furthermore, the red wire's power supply for the front cam becomes active with manually front camera switching (short press of the external keypad).

If set to **OFF**, the video interfaces' red wire will supply permanent +12V ACC (max 3A).

Description of the power supply output: see chapter "Power supply output".

1.6.2. Enabling the interface's video inputs (dip 2-3)

Only the enabled video inputs can be accessed by switching through the interface's video sources. It is recommended to enable only the required inputs. Then the disabled inputs will be skipped while switching through the video interfaces inputs.

1.6.3. Rear-view camera settings (dip 5)

If set to **OFF**, the interface switches to factory picture while the reverse gear is engaged to display factory rear-view camera or factory optical park system picture.

If set to **ON**, the interface switches to its rear-view camera input while the reverse gear is engaged.

1.6.4. Activating – front camera back-switching (dip 6)

If set to **ON**, the interface switches for 10 seconds from the rear-view camera to the front camera input after having disengaged the reverse gear. In addition, a manual switch-over to the front camera input is possible via keypad (short press) from any image mode.

(Attend to correct adjustment of the power supply output (dip1)!

1.6.5. Head unit selection (Dip 8)

Dipswitch 8 is used to set the corresponding resolution of the factory monitor.

Dip switch position ON supports the low resolution monitor.

Dip switch position OFF supports the high resolution monitor.

Note: If you do not know the resolution, test both settings.

Note: Dip4 and 7 are out of function and have to be set to **OFF**.

After each Dip-switch-change a power-reset of the interface box has to be performed!

1.7. Settings of the 4 Dip switches (CAN function - red)

Dip position down is **ON** and position up is **OFF**.

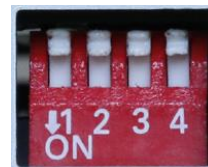

Navigation / Sy5tem	Dip 1	Dip 2	Dip 3	Dip 4
NAC infotainments	OFF	OFF	OFF	OFF

Set all 4 dips to OFF.

After each Dip-switch-change a power-reset of the Can-box has to be performed!

2. Installation

Switch off the ignition and disconnect the vehicle's battery! The interface needs a permanent 12V source. If -according to factory rules- a disconnection of the battery has to be avoided, it should be sufficient to use the vehicle's sleep-mode. In case, the sleep-mode doesn't succeed, the battery has to be disconnected with a resistor lead.

The connection's power has to be checked for being start-up proven and permanent.

Before the final installation, we recommend a test-run of the interface. Due to changes in the production of the vehicle manufacturer, there's always the possibility of incompatibility.

2.1. Place of installation – video-interface

The video-interface is performed to be installed at the head unit's rear side.

Erfahrungswerte zu Einbauorten:

Radio/Navi in **Peugeot 2008 FY 2019** vehicles: Directly behind the display.

Head Units in **Peugeot 5008** and Opel **Grandland X** vehicles: Behind the centre console (for this, remove the panel in the passenger footwell).

Attention!
Do not connect to vehicle monitor
Damage to hardware!

2.2. Connection schema

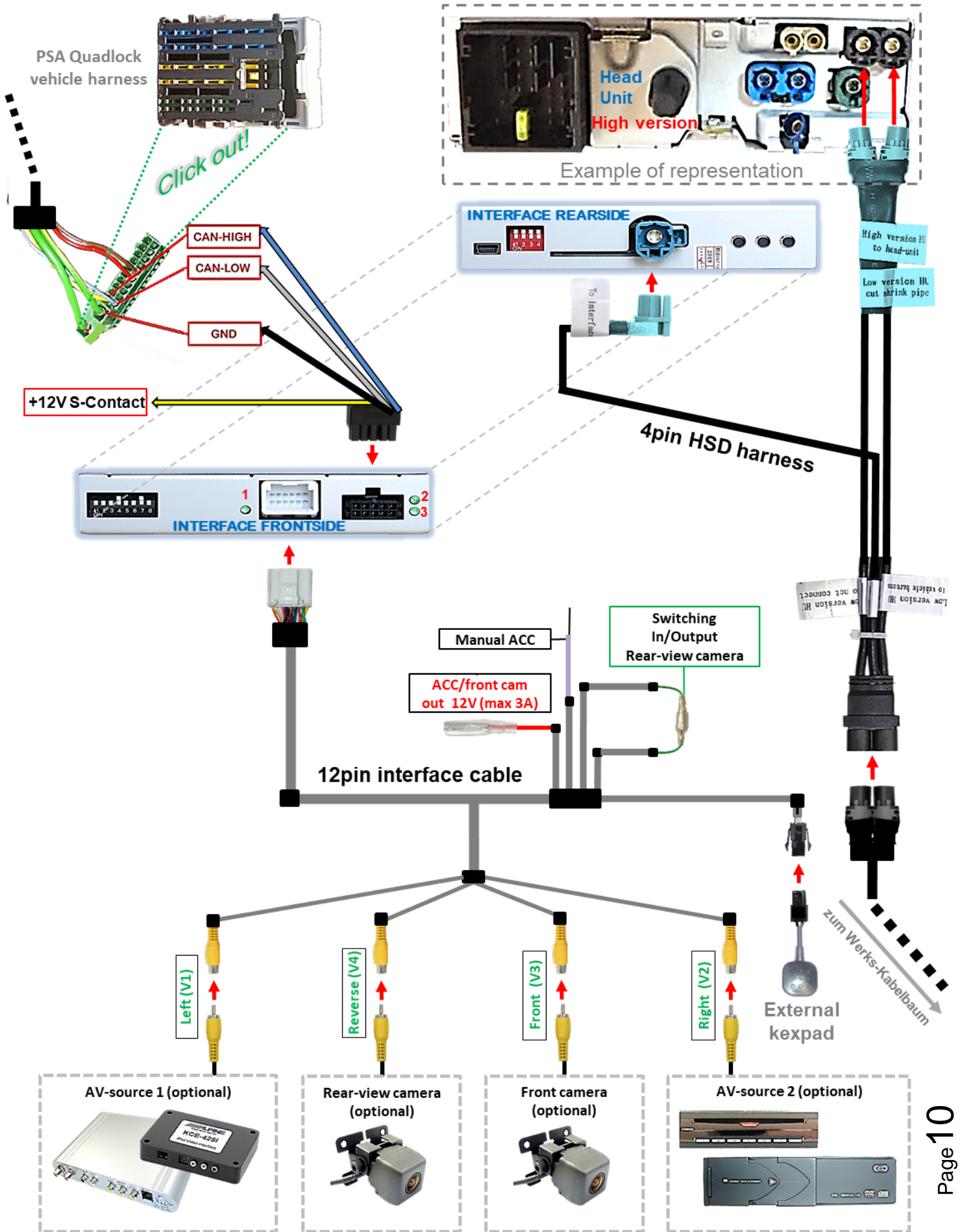

2.3.1.2. Low version head unit (1 X 4pin HSD)

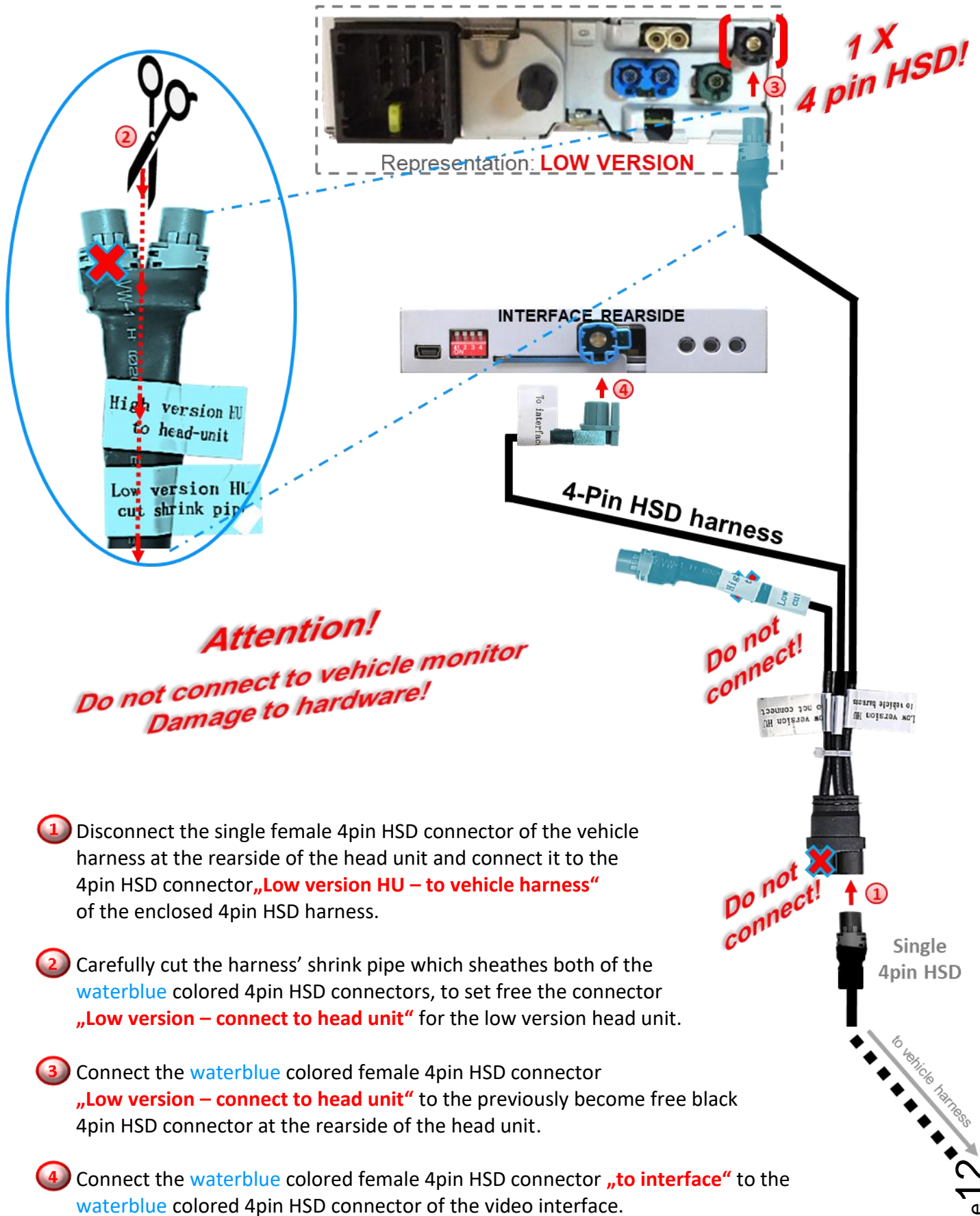

- ① Disconnect the single female 4pin HSD connector of the vehicle harness at the rearside of the head unit and connect it to the 4pin HSD connector „**Low version HU – to vehicle harness**“ of the enclosed 4pin HSD harness.
- ② Carefully cut the harness' shrink pipe which sheathes both of the **waterblue** colored 4pin HSD connectors, to set free the connector „**Low version – connect to head unit**“ for the low version head unit.
- ③ Connect the **waterblue** colored female 4pin HSD connector „**Low version – connect to head unit**“ to the previously become free black 4pin HSD connector at the rearside of the head unit.
- ④ Connect the **waterblue** colored female 4pin HSD connector „**to interface**“ to the **waterblue** colored 4pin HSD connector of the video interface.

2.3.2. Connection – Power / CAN

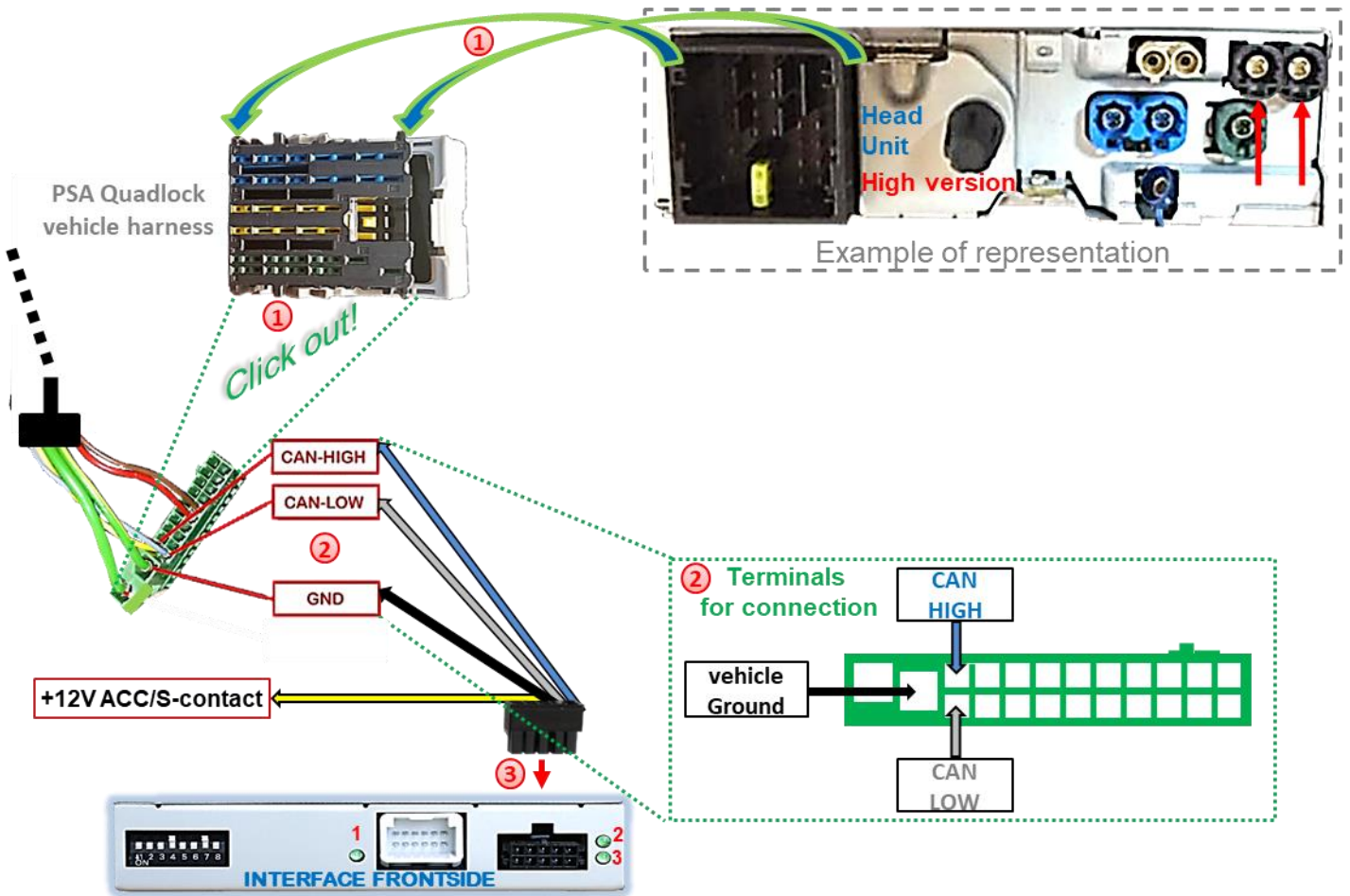

- 1 Disconnect the female PSA Quadlock connector at the rear of the head unit and click out the green female 22pin connector of the female PSA Quadlock connector.
- 2 Connect the single four cables of the POWER / CAN cable to ACC and exactly to the 22pin connector's shown chambers, as the vehicle's cable colours may vary!
- 3 Connect the power / CAN cable's female 10pin connector to the 10pin connector of the video interface.



Check 1

Exceptionally, the GM LAN communication may not succeed in all vehicles! If, after connecting the PNP harness, no interface LED lightens up while the ignition is turned on, the analog power supply needs to be done! (see following chapter)

Check 2

Exceptionally, the power supply to the video interfaces may not be interrupted after switching to the vehicle's sleep mode. If the interface LEDs continue to shine even in the vehicle's sleep mode, please contact the support!

2.3.3. Analog power supply for the video interface

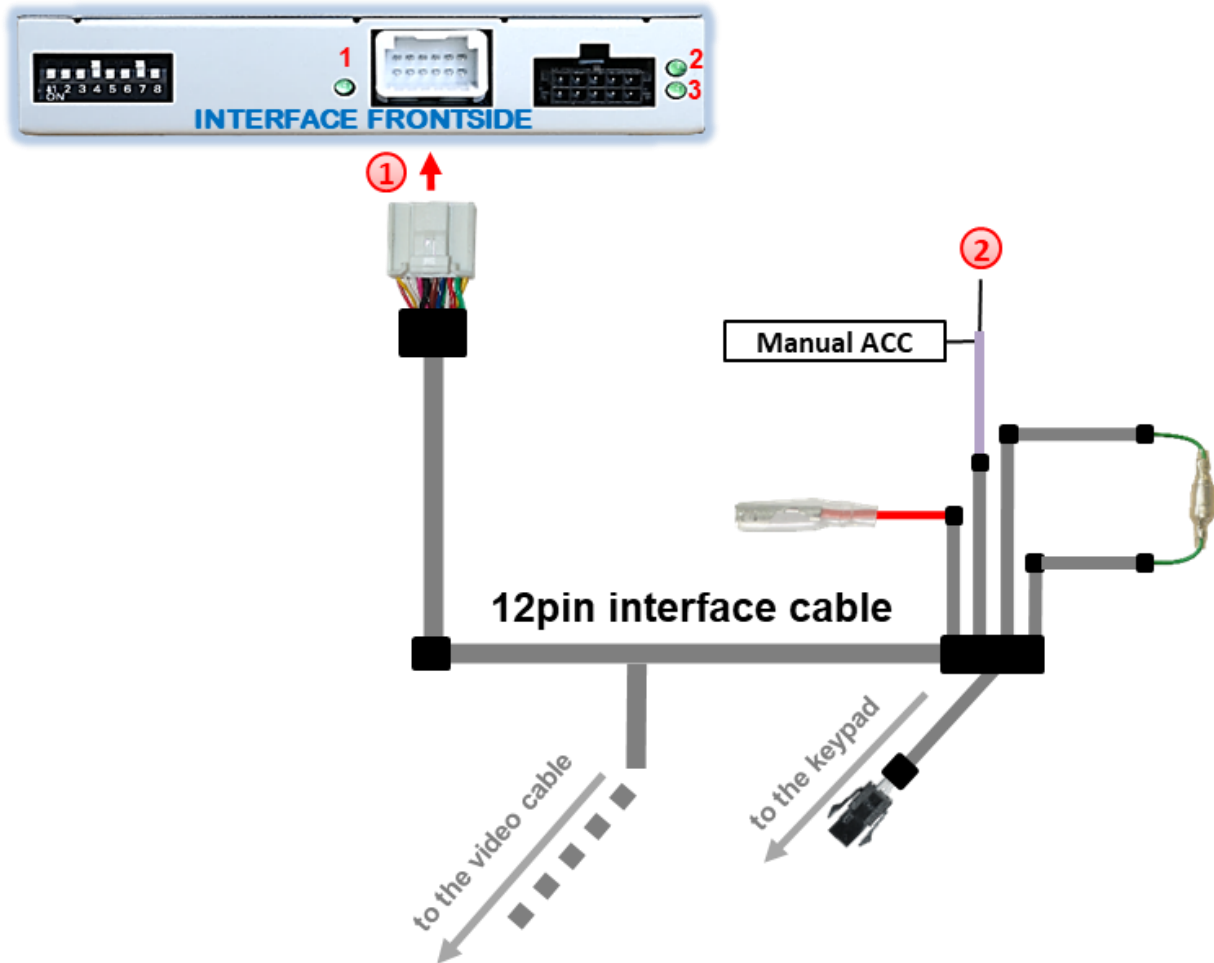

- ① Connect the female 12pin connector of the 12pin interface cable to the male 12pin connector of the video interface.
- ② Connect the 12pin interface cable's purple coloured wire **Manual ACC** to +12V **ACC** or to +12V **S-contact terminal 86s +12V** (e.g. glove compartment illumination).

2.4. Power supply output

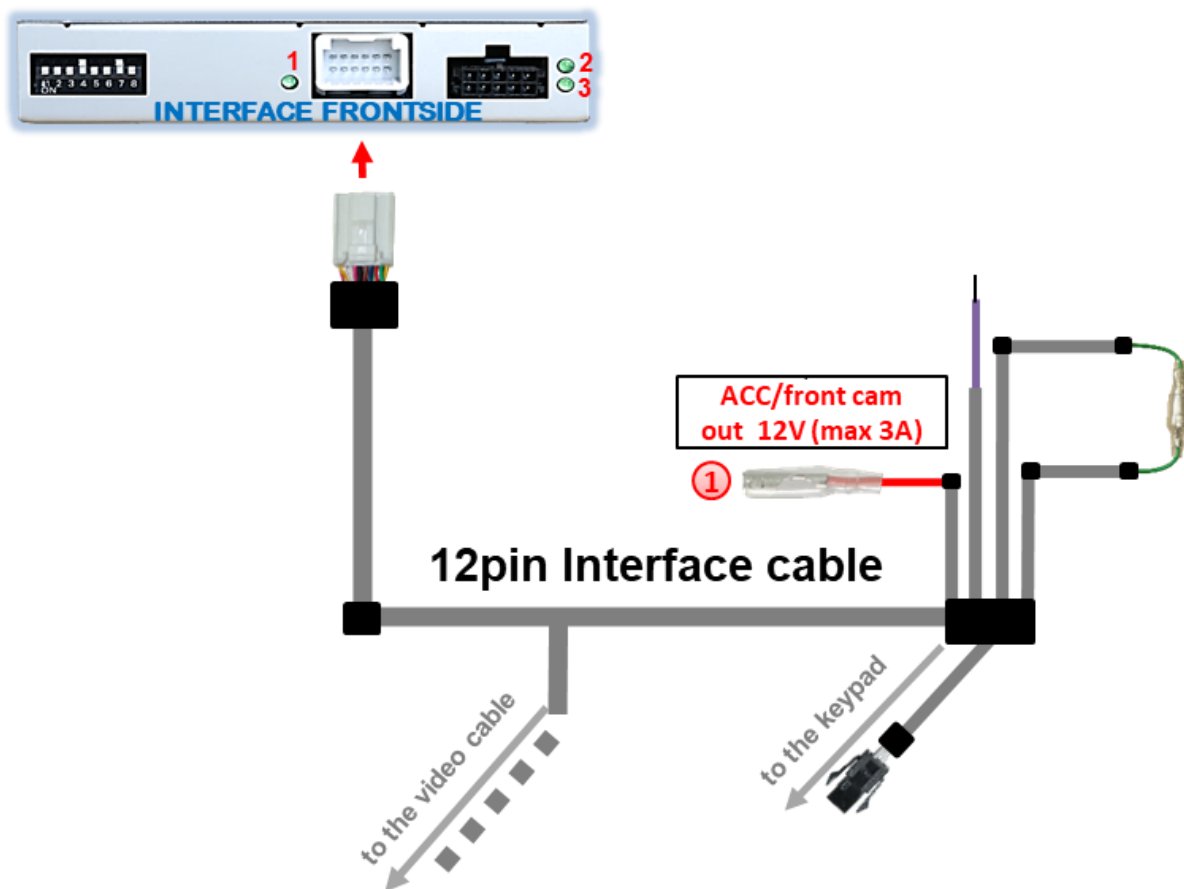

The red power supply output **ACC/front cam out 12V (max 3A)** can be used to power an external source and has a different assignment depending on the position of dip switch 1 (of the black 8 dips):

Dip	Function
Dip 1 ON	+12V (max. 3A) when reverse gear is engaged incl. 10 seconds delay after reverse gear is disengaged and +12V by manual switching to front camera by keypad (short press)
Dip 1 OFF	+12V (max. 3A) simulated ACC (while CAN has activity)

2.5. Connection - video sources

It is possible to connect two after-market video-sources, an after-market rear-view camera and an after-market front camera to the video-interface.

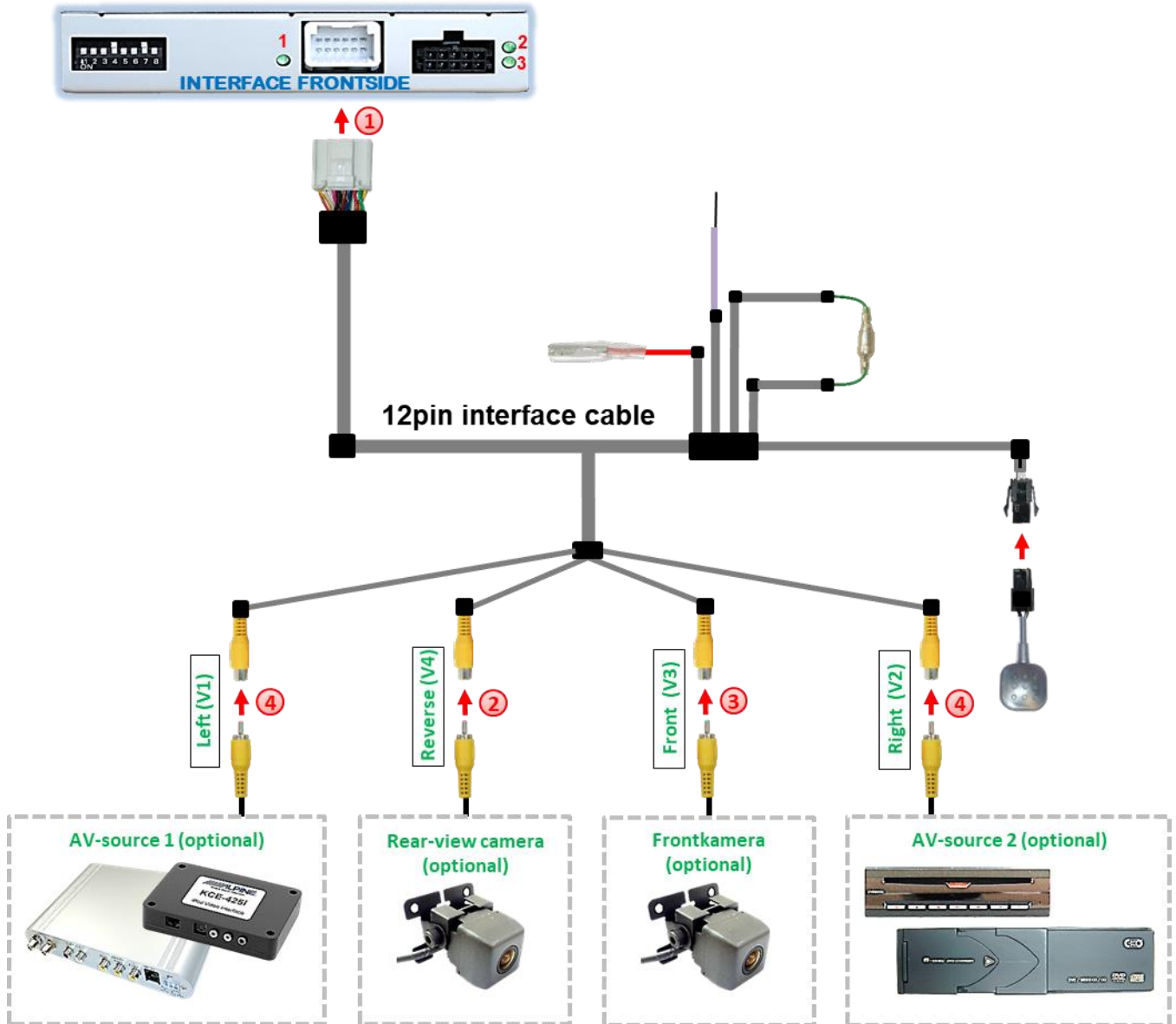

- 1 Connect the 12pin interface cable's female 12pin connector to the male 12pin connector of the video-interface.
- 2 Connect the video RCA of the rear-view camera to the 12pin interface cable's female RCA connector „Reverse V4“.
- 3 Connect the front camera's video RCA connector to the 12pin interface cable's female RCA connector „Front V3“.
- 4 Connect the video RCA of the AV source 1 and 2 to the 12pin interface cable's female RCA connector “Left (V1)” and “Right (V2)”.

2.5.1. Audio insertion

This interface can only insert video signals into the factory infotainment. If an AV source is connected, the audio insertion has to be performed by a factory aux input or an FM modulator. The inserted video-signal can be activated simultaneously to each audio-mode of the factory infotainment.

If 2 AV-sources shall be connected to the infotainment, for audio switching an additional electronic part is required.

2.5.2. After-market front camera

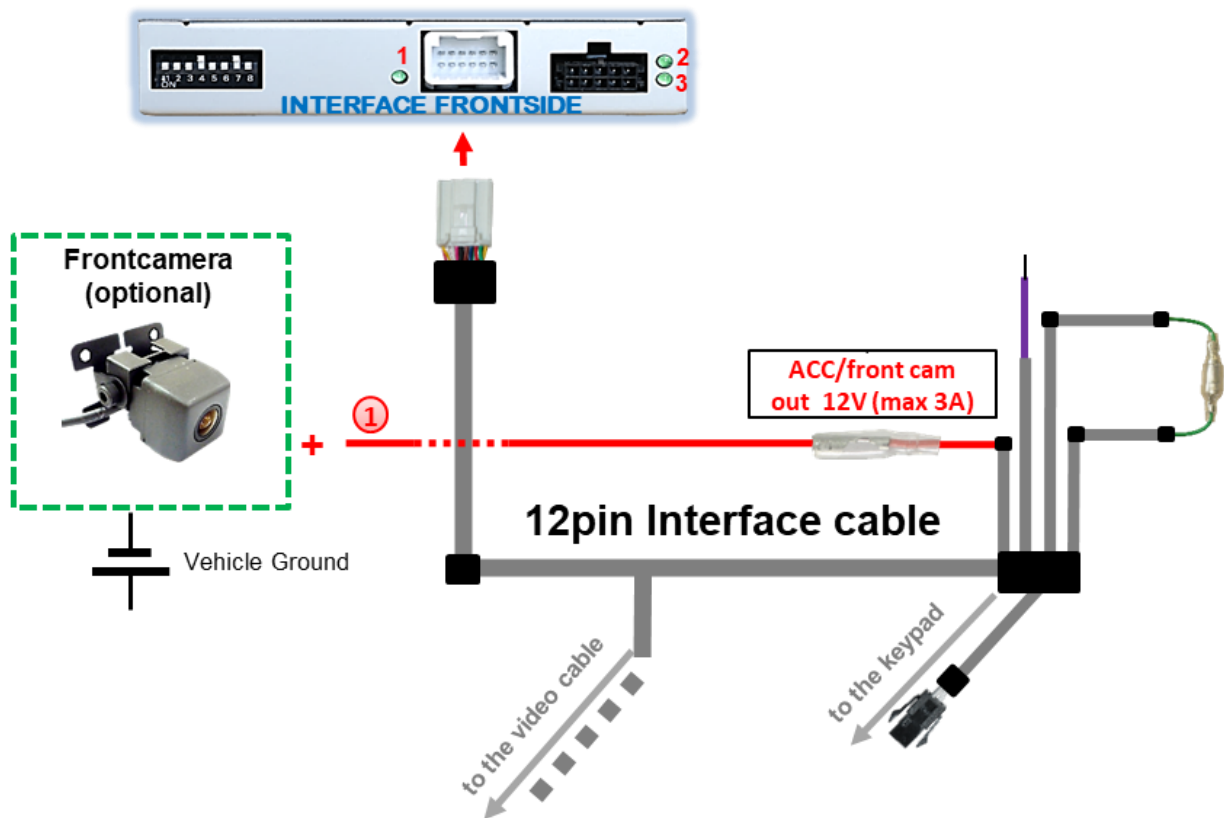

- 1 The red power supply output **ACC/front cam out 12V (max 3A)** can be used to power a front camera. If Dip 1 is set to ON (of the black 8 daps), the power supply output supplies +12V (max 3A) when the reverse gear is engaged and additionally 10 seconds delay after reverse gear is disengaged.

Note: In addition, a manual switch-over to the front camera input is possible via keypad (short press) from any image mode. The power supply output supplies +12V then, too (if Dip 1 is set to ON and the front camera input is selected).

2.5.3. After-market rear-view camera

Some vehicles have a different reverse gear code on the CAN-bus which the video-interface is not compatible with. Therefore, there are two different ways of installation. If the video interface receives a signal of the reverse gear, the green wire **“Reverse-OUT”** of the 20pin cable should carry +12V while the reverse gear is engaged.

Note: Do not forget to set dip5 of the video-interface to **ON** before testing.

2.5.3.1. Case 1: Video interface receives the reverse gear signal

If the CAN-bus interface receives +12V on the green wire of the 20pin cable when reverse gear is engaged, it will automatically be switched to the rear-view camera input “Camera IN” while reverse gear is engaged.

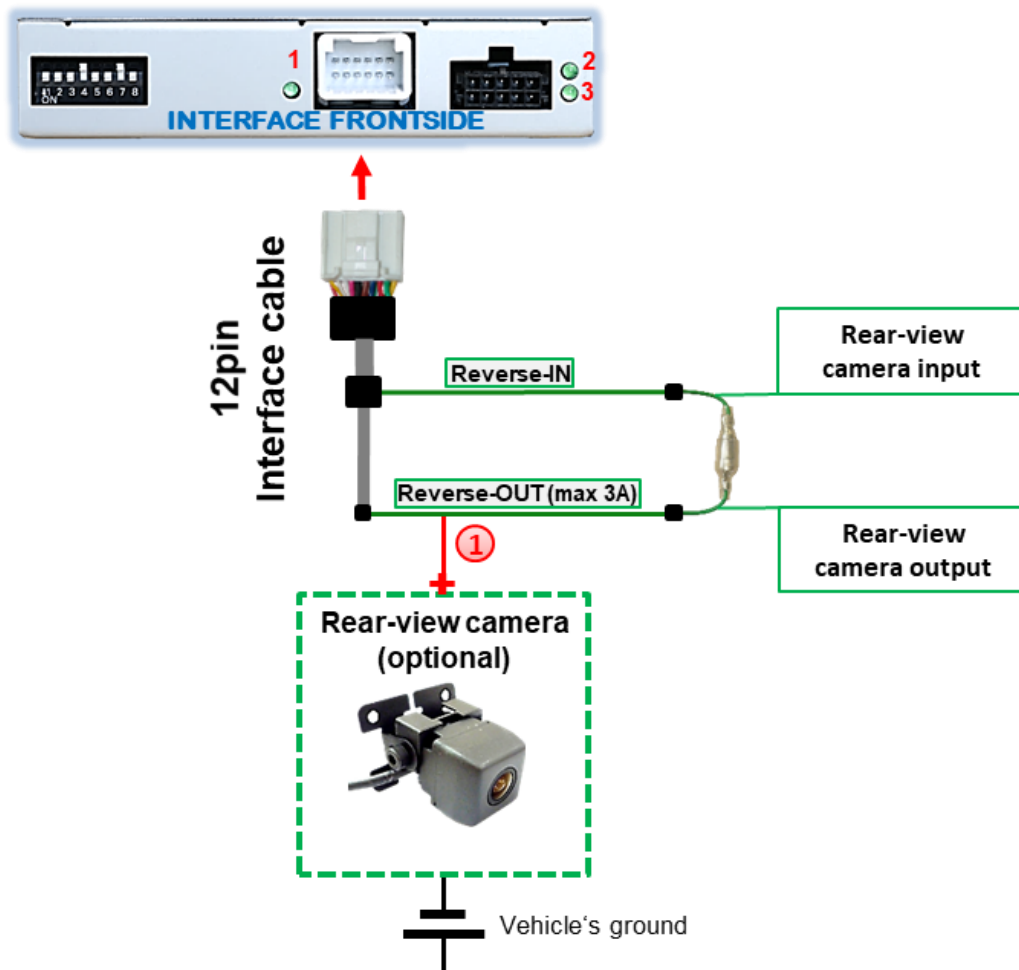

- 1** The 12 V power supply for the rear-view camera (max 3A) has to be taken from the green wire of the 20pin cable to avoid an unnecessary, permanent power supply to the camera electronic.
For the operation, both green cables **“Reverse IN”** and **“Reverse OUT”** have to remain connected.

2.5.3.2. Case 2: Video interface does not receive the reverse gear signal

If the video interface does not receive +12V on the green wire of the 20pin cable when reverse gear is engaged (not all vehicles are compatible), an external switching signal from the reverse gear light is required. As the reverse gear light's power supply isn't voltage-stable all the time, an ordinary open relay (e.g AC-RW-1230 with wiring AC-RS5) or filter (e.g. AC-PNF-RVC) is required. The diagram below shows the connection type of the relay.

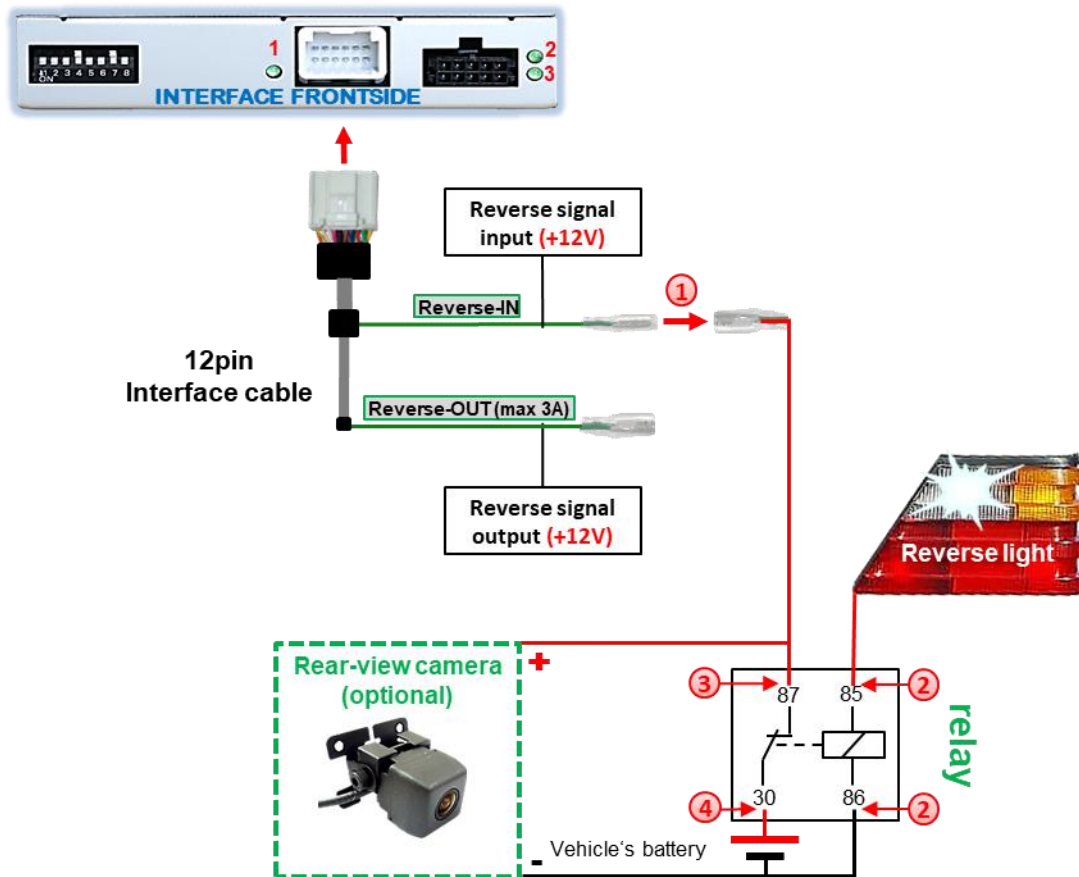

- ① Disconnect the green cable's pre-connected male- and female connectors of the 20pin cable and connect the green input cable "Reverse-IN" to the output connector (87) of the relay.

Note: Not least to avoid short circuits, the best solution should be, to crimp a male 4mm connector to the relay's output cable and connect it to the green cable's female 4mm connector. The output-cable "Reverse-OUT" remains disconnected as it's out of function.

- ② Connect the Reverse light's power-cable to coil (85) and the vehicle's ground to coil (86) of the relay.
- ③ Connect the output connector (87) of the relay to the rear-view camera's power-cable, like you did it to the green "Reverse-IN" cable before.
- ④ Connect permanent power / 12V to the relay's input connector (30).

2.6. Connection - external keypad

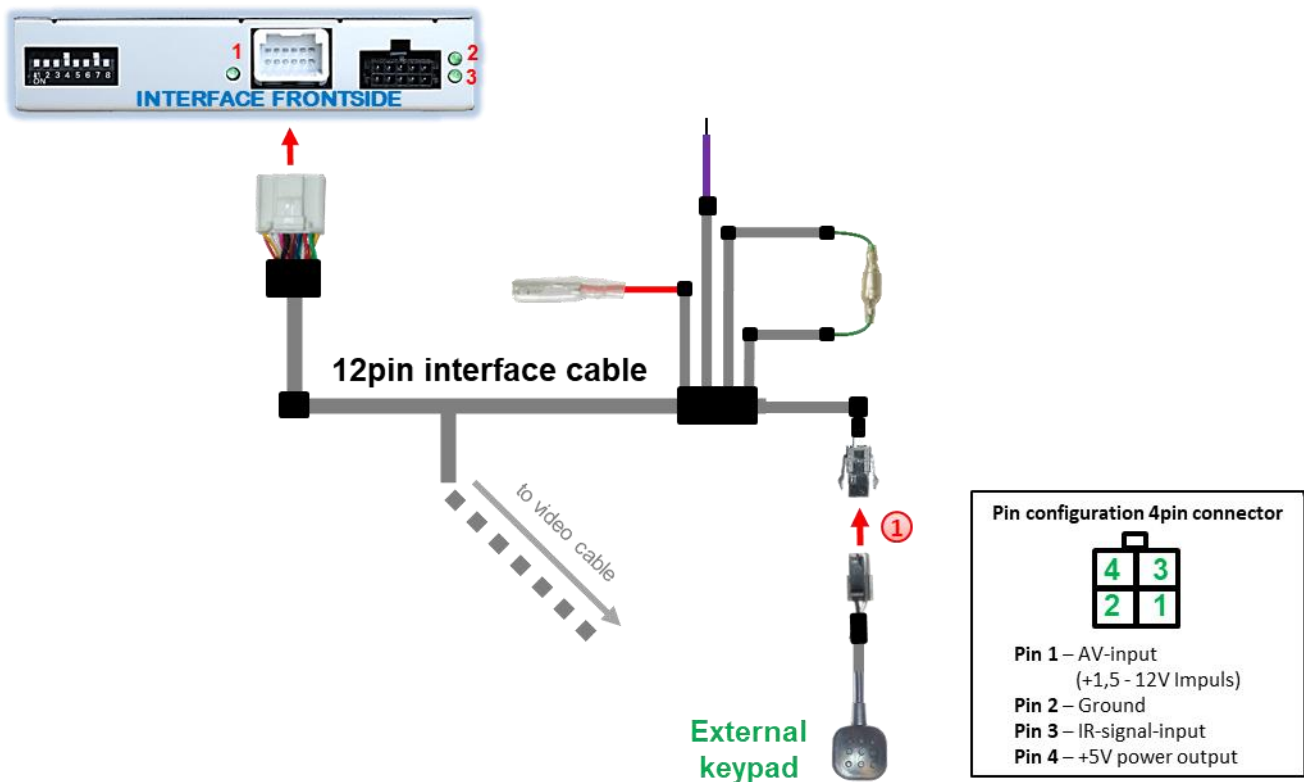

- 1 Connect the keypad's female 4pin connector to the video-interface's male 4pin connector.

Note: Even if the switching through several video sources by the keypad mightn't be required, the invisible connection and availability is strongly recommended.

2.7. Picture settings and guide lines

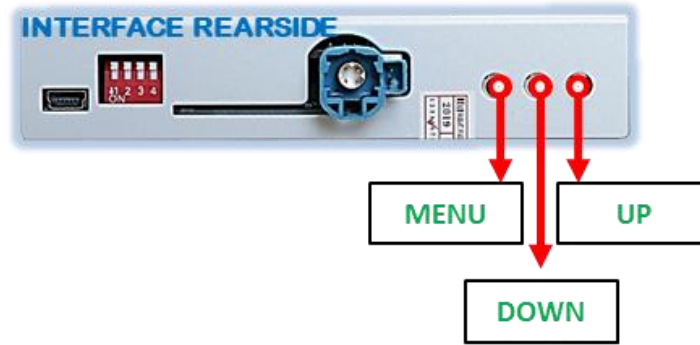

The picture settings can be adjusted by the 3 buttons on the video-interface. Press the **MENU** button to open the OSD settings menu. To switch to the next menu item, pressing **UP** and **DOWN** will change the selected value. The buttons are embedded in the housing to avoid accidental changes during or after installation. The picture settings have to be done separately for AV1 and AV2 while the corresponding input is selected and visible on the monitor.

Note: The OSD menu is only shown when a working video source is connected to the selected video-input of the interface.

The following settings are available:

Contrast	
Brightness	
Saturation	
Position H	horizontal picture position
Position V	vertical picture position
IR-AV1	(out of function)
IR-AV2	(out of function)
Guide-L	Guide lines position
UI-CNTRL	Options – see pink diagram
Guide-CNTRL -	Guide lines for rear-view camera /PDC
H-SIZE	horizontal picture size RVC
V-SIZE	vertical picture size RVC



Options:

- ALL ON:** Guide lines and PDC will be displayed.
- PDC ON:** Only PDC displayed.
- Guide ON:** Only Guide lines displayed.
- ALL Off:** Guide lines and PDC will not be displayed.

The menu's point „UI-CNTRL“ does support the guide lines options like shown beside:

If there is no communication between interface and the vehicle's CAN-bus (several vehicles aren't compatible), the optical PDC and the reverse gear guide-lines can't be shown during the vehicle's operation, even if they once appear after having switched the system to powerless!

3. Interface operation

3.1. By Navi button

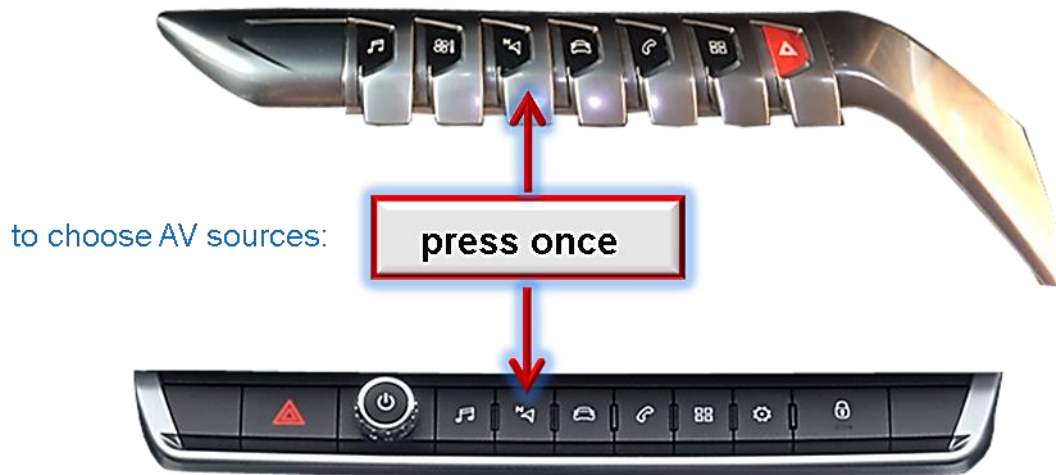

A press of the infotainment's "Navi"-button switches the input from factory mode to the inserted video sources. If, by dip switch setting, all inputs are enabled, the order is the following:

Factory video → video IN1 → video IN2 → factory video →...

By dip switch deactivated inputs will be skipped.

Switchover by vehicle buttons isn't possible in all vehicles. In some vehicles the external keypad has to be used.

3.2. By keypad

Alternatively or additionally to the infotainment's "Navi" button, the interface's enabled inputs can also be switched by the external keypad.

➤ Long press of keypad (2-3 seconds)

By long pressing the external keypad (2-3 seconds), the video interfaces switches the input from the factory video to the inserted video sources. If all inputs are activated by dip switch settings, the order is the following:

Factory video → Left (V1) → Right (V2) → factory video

Each long press will switch to the next enabled input. Inputs which are not enabled will be skipped.

Note: The interface switches after releasing the switch (after long pressure).

➤ Short press of keypad (only if DIP 1 is set to ON)

By short pressing the external keypad, the video interfaces switches from the factory video to the front camera input and back to factory video.

4. Specifications

BATT/ACC range	7V - 25V
Stand-by power drain	15mA
Power	310mA @12V
Video input	0.7V – 1V
Video input formats	NTSC
Temperature range	-40°C to +85°C
Dimensions Video-Box	118 x 23 x 105 mm (W x H x D)

5. FAQ – Trouble shooting Interface functions

For any troubles which may occur, check the following table for a solution before requesting support from your vendor.

Symptom	Reason	Possible solution
No picture/black picture (factory picture).	Not all connectors have been reconnected to factory head-unit or monitor after installation.	Connect missing connectors.
	No power on CAN-bus box (all LED CAN-bus box are off).	Check power supply of CAN-bus box. Check CAN-bus connection of CAN-bus box.
	CAN-bus box connected to CAN-bus in wrong place.	Refer to the manual where to connected to the CAN-bus. If not mentioned, try another place to connect to the CAN-bus.
	No power on video-interface (all LED video-interface are off).	Check whether CAN-bus box delivers +12V ACC on red wire output of 8pin to 6pin cable. If not cut wire and supply ACC +12V directly to video-interface.
No picture/black picture/white picture (inserted picture) but factory picture is OK.	No picture from video source.	Check on other monitor whether video source is OK.
	No video-source connected to the selected interface input.	Check settings dips 1 to 3 of video interface which inputs are activated and switch to corresponding input(s).
	LVDS cables plugged in wrong place.	Double-check whether order of LVDS cables is exactly connected according to manual. Plugging into head-unit does not work when the manual says to plug into monitor and vice versa.
Inserted picture totally wrong size or position.	Wrong monitor settings of video-interface.	Try different combinations of dips 7 and 8 of video-interface. Unplug 6pin power after each change.
Inserted picture double or 4 times on monitor.		
Inserted picture distorted, flickering or running vertically.	Video sources output set to AUTO or MULTI which causes a conflict with the interfaces auto detection.	Set video source output fixed to PAL or NTSC. It is best to set all video sources to the same standard.
	If error occurs only after source switching: Connected sources are not set to the same TV standard.	Set all video sources to the same standard.
	Some interfaces can only handle NTSC input.	Check manual whether there is a limitation to NTSC mentioned. If yes, set source fixed to NTSC output.
Inserted picture b/w.	Picture settings have not been adjusted.	Use the 3 buttons and the interface's OSD to adjust the picture settings for the corresponding video input.
Inserted picture qual. bad.		
Inserted picture size slightly wrong.		
Inserted picture position wrong.		
Camera input picture flickers.	Camera is being tested under fluorescent light which shines directly into the camera.	Test camera under natural light outside the garage.
Camera input picture is bluish.	Protection sticker not removed from camera lens.	Remove protection sticker from lens.

Symptom	Reason	Possible solution
Camera input picture black.	Camera power taken directly from reverse gear lamp.	Use relay or electronics to "clean" reverse gear lamp power. Alternatively, if CAN-bus box is compatible with the vehicle, camera power can be taken from green wire of 6pin to 8pin cable.
Camera input picture has distortion.		
Camera input picture settings cannot be adjusted.	Camera input picture settings can only be adjusted in AV2 mode.	Set dip 3 of video-interface to ON (if not input AV2 is not already activated) and connect the camera to AV2. Switch to AV2 and adjust settings. Reconnect camera to camera input and deactivate AV2 if not used for other source.
Graphics of a car in camera input picture.	Function PDC is ON in the interface OSD.	In compatible vehicles, the graphics will display the factory PDC distance. If not working or not wanted, set interface OSD menu item UI-CNTRL to ALLOFF.
Chinese signs in camera input picture	Function RET or ALL is ON (function for Asian market) in the interface OSD.	Set interface OSD menu item UI-CNTRL to ALLOFF or PDCON.
Not possible to switch video sources by OEM button.	CAN-bus interface does not support this function for vehicle.	Use external keypad or cut white wire of 6pin to 8pin cable and apply +12V impulses for AV-switching.
Not possible to switch video sources by external keypad.	Pressed too short.	For video source switching a longer press of about 2.5 seconds is required.
	SW-version of interface does not support external keypad.	Use OEM-button or cut white wire of 6pin to 8pin cable and apply +12V impulses for AV-switching.
Interface does not switch to camera input when reverse gear is engaged.	CAN-bus interface does not support this function for the vehicles.	Cut the green wire of the 6pin to 8pin cable and apply +12V constant from reverse gear-lamp signal. Use relay to "clean" R-gear lamp power.
Interface switches video-sources by itself.	CAN-bus interface compatibility to vehicle is limited.	Cut the grey wire of 6pin to 8pin and isolate both ends. If problem still occurs, additionally cut the white wire of 6pin to 8pin cable and isolate both ends.

6. Technical Support

Please note that direct technical support is only available for products purchased directly from NavLinkz GmbH. For products bought from other sources, contact your vendor for technical support.

NavLinkz GmbH
distribution/tech dealer-support
 Heidberghof 2
 D-47495 Rheinberg

Tel +49 2843 17595 00
 Email mail@navlinkz.de

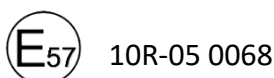

Made in China

