

Video-inserter VL1-NG4-HU

Compatible with

Alfa Romeo, Citroen, Peugeot, Maserati
vehicles with infotainment NG4 with colour display
and 10pin LVDS monitor connector



**Video-inserter for rear-view camera
and two additional video sources**

Product features

- Video-inserter for factory-infotainment systems
- 1 CVBS Rear-view camera video-input
- 2 CVBS video-inputs for after-market devices (e.g. USB-Player, DVB-T2 tuner, ...)
- Automatic switching to rear-view camera input on engagement of reverse gear
- Video-in-motion (ONLY for connected video-sources)
- Video-inputs NTSC compatible

Contents

1. Prior to installation

- 1.1. Delivery contents
- 1.2. Checking the compatibility of vehicle and accessories
- 1.3. Connectors – video interface
- 1.4. Dip-switch settings
 - 1.4.1. Enabling the interface's video inputs (dip 2-3)
 - 1.4.2. Rear-view camera setting (dip 5)
 - 1.4.3. Monitor selection (dip 7-8)

2. Installation

- 2.1. Place of installation
- 2.2. Connection schema
- 2.3. Connection – 6pin interface cable
- 2.4. Connection - head-unit
- 2.5. Connection - Video-sources
 - 2.5.1. Audio-switch and audio-insertion
 - 2.5.2. After-market rear-view camera
- 2.6. Connection – external keypad
- 2.7. Picture settings

3. Interface operation

4. Specifications

5. FAQ - Trouble shooting Interface functions

6. Technical support

Legal Information

By law, watching moving pictures while driving is prohibited, the driver must not be distracted. We do not accept any liability for material damage or personal injury resulting, directly or indirectly, from installation or operation of this product. This product should only be used while standing or to display fixed menus or rear-view-camera video when the vehicle is moving, for example the MP3 menu for DVD upgrades.

Changes/updates of the vehicle's software can cause malfunctions of the interface. We offer free software-updates for our interfaces for one year after purchase. To receive a free update, the interface must be sent in at own cost. Labor cost for and other expenses involved with the software-updates will not be refunded.

1. Prior to installation

Read the manual prior to installation.

Technical knowledge is necessary for installation. The place of installation must be free of moisture and away from heat sources.

1.1. Delivery contents

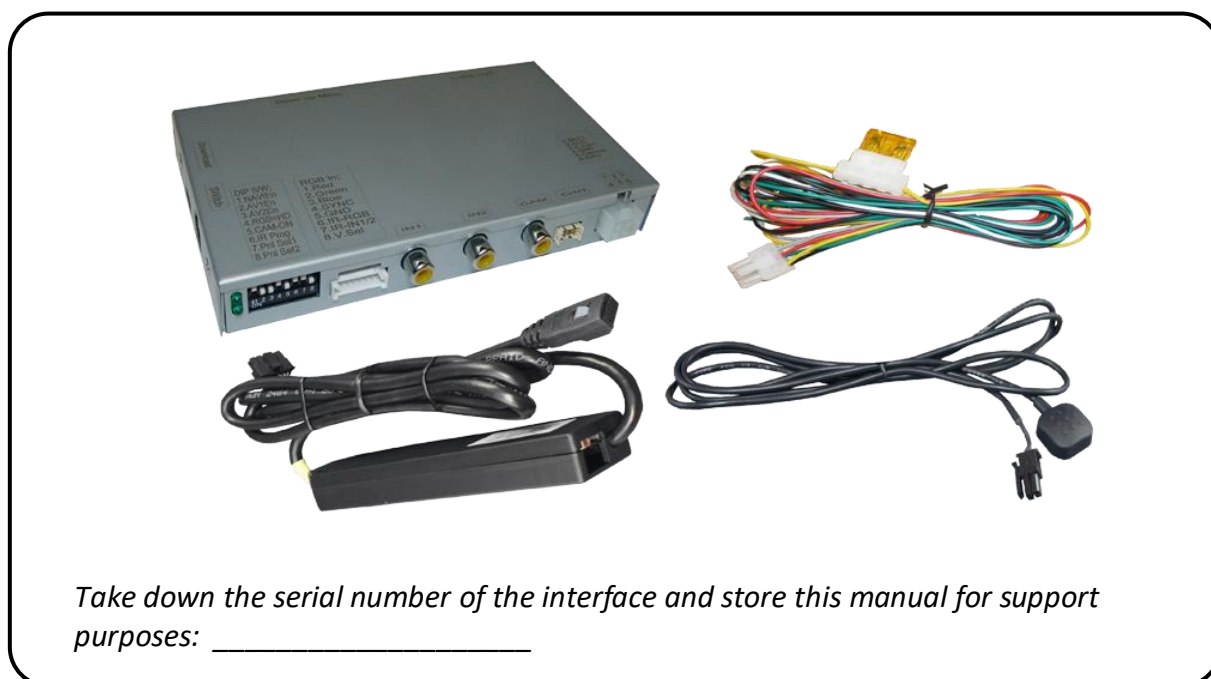

1.2. Checking the compatibility of vehicle and accessories

Requirements		
Brand	Model	Navigation
Alfa Romeo	Giulietta (940)	Blue&Me
Citroen	Berlingo (B9) 04/2008-03/2015, C3 11/2009-ca.2015, C3 Picasso 02/2009-07/2017, C4 (N) 08/2010-12/2014, C4 Picasso 09/2006-03/2013, C5 model years 2008-2017, C6 09/2005-12/2012, C8 model years 2008-2014, DS3 03/2010 – model year 2015, DS4 05/2011 – model year 2014, DS5 11/2011-03/2015, Jumpy II 2009-2015	NaviDrive RT3evo/4/5, MyWay RNEG, NaviDrive 3D NG4, eMyWay
Maserati	GranCabrio 2010-2017, GranTurismo 2007-2017, Quattroporte 2009-2012	N3 Magneti Marelli
Peugeot	1007 12/2006-12/2009, 207 02/2011-05/2012, 307 01/2007-03/2008, 307CC 01/2007-03/2009, 308 09/2007-2014, 308CC 04/2009-2015, 3008 06/2009-10/2016, 407 10/2006-12/2011, 508 10/2010-07/2014, 5008 10/2009-01/2017, 607 08/2006-09/2010, Expert II 07/2007-2016, Partner II 11/2007-05/2015, RCZ 02/2010-12/2015	WIP Com/Connect Com RT3evo/4/5/6, RNEG, WIP Com/Connect Com 3D NG4, WIP Nav+/Connect Nav+
Limitations		
<i>Video only</i>	The interface inserts ONLY video signals into the infotainment. For sound use the possibly existing factory-audio-AUX-input or a FM-modulator. If 2 AV sources shall be connected, the CAB-FV-AUDIO audio cable is optionally available for audio switching.	
<i>Factory rear-view camera</i>	Automatic switch-back from inserted video to factory rear-view camera only while reverse gear is engaged. To delay the switch-back time, additional electronics is required.	
<i>Video input signal</i>	NTSC video sources compatible only.	

1.3. Connectors – video interface

The video-interface converts the connected after-market sources video signals to an LVDS signal which is the inserted into the factory monitor on certain trigger options.

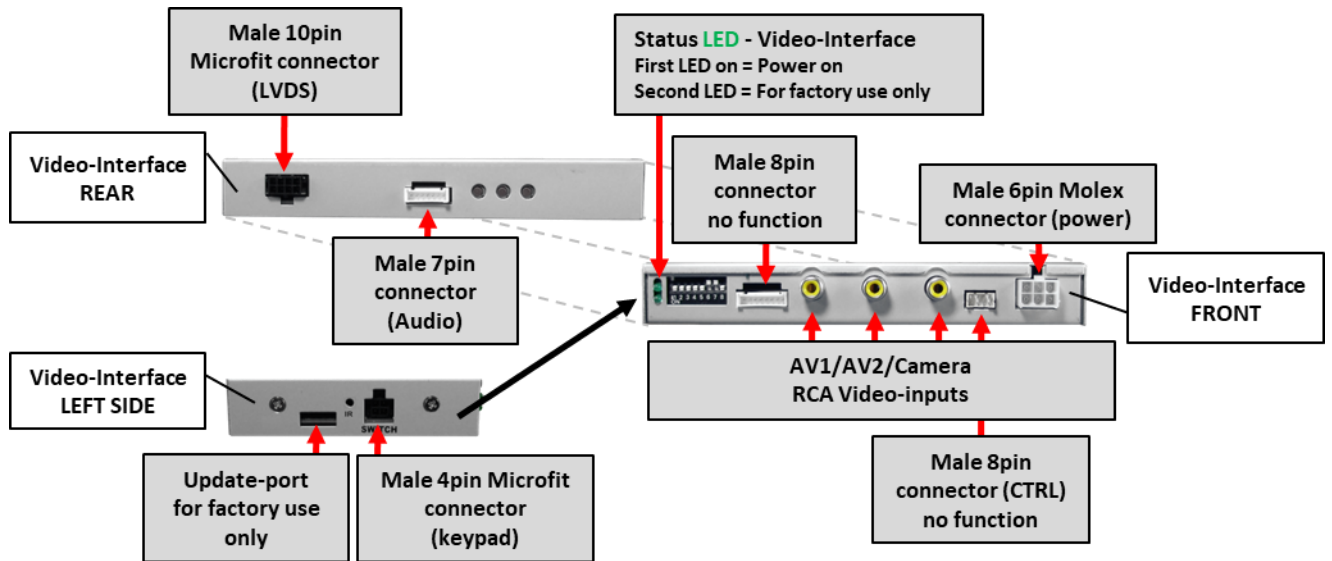

1.4. Dip-switch settings



Some settings must be selected by the dip-switches on the video-interface. Dip position down is ON and position up is OFF.

Dip	Function	ON (down)	OFF (up)
1	No function		set to OFF
2	CVBS AV1-input	enabled	disabled
3	CVBS AV2-input	enabled	disabled
4	No function		set to OFF
5	Rear-view cam type	after-market	factory or none
6	No function	-	set to OFF
7	Monitor selection	Try all 4 possible combinations of dip 7 and 8 to find the best picture (quality and size)	
8			

See following chapters for detailed information.

1.4.1. Enabling the interface's video inputs (dip 2-3)

Only the enabled video inputs can be accessed when switching through the interface's video sources. It is recommended to enable only the required inputs for the disabled will be skipped when switching through the video-interfaces inputs.

1.4.2. Rear-view camera setting (dip 5)

If set to OFF, the interface switches to factory LVDS picture while the reverse gear is engaged to display factory rear-view camera or factory optical park system picture.

If set to ON, the interface switches to its rear-view camera input CAM while the reverse gear is engaged.

1.4.3. Monitor selection (dip 7-8)

Dip 7 and 8 are for monitor-specific video settings which cannot be predicted as even within the same head-unit version, the monitor specifications may vary. It is necessary to try all possible combinations (both OFF, both ON, 7 OFF and 8 ON, 7 ON and 8 OFF) - while a working video source is connected to the chosen input of the interface - to see which combination gives the best picture quality and size (some may give no picture). It is possible to first hot plug through the dip combinations, but if you do not experience any change of picture after trying all 4 options, retry and disconnected the 6pin power plug of the video-box between every change of the dip setting.

Dip1, 4 and 6 are out of function and have to be set to OFF

2. Installation

Switch off ignition and disconnect the vehicle's battery! The interface needs a permanent 12V source. If according to factory rules disconnecting the battery is to be avoided, it is usually sufficient to put the vehicle in sleep-mode. In case the sleep-mode does not show success, disconnect the battery with a resistor lead.

If power source is not taken directly from the battery, the connection has to be checked for being start-up proven and permanent.

2.1. Place of installation

The interface is performed to be installed at the **rear-side of the head-unit**.

2.2. Connection schema

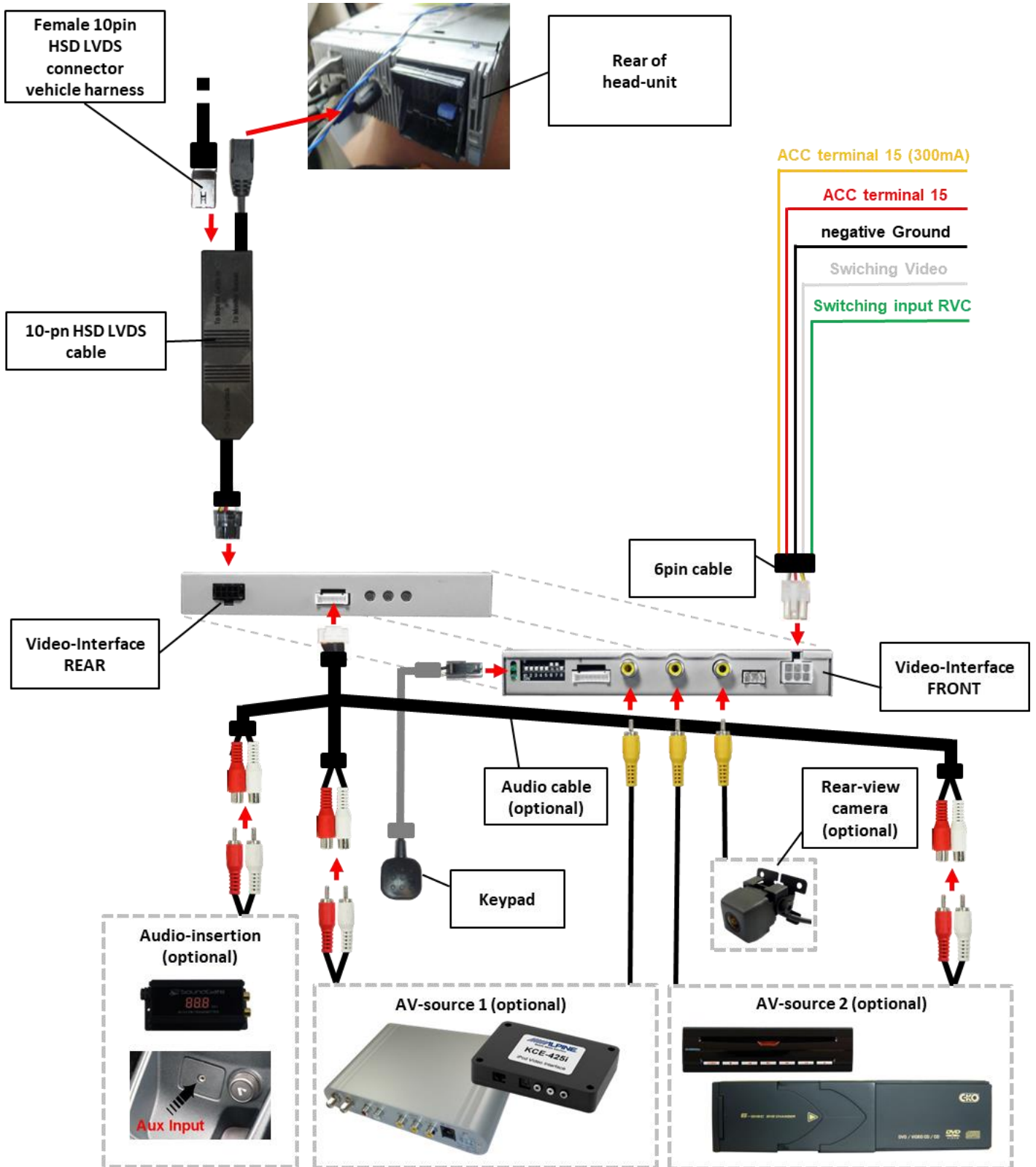

2.3. Connection – 6pin interface cable

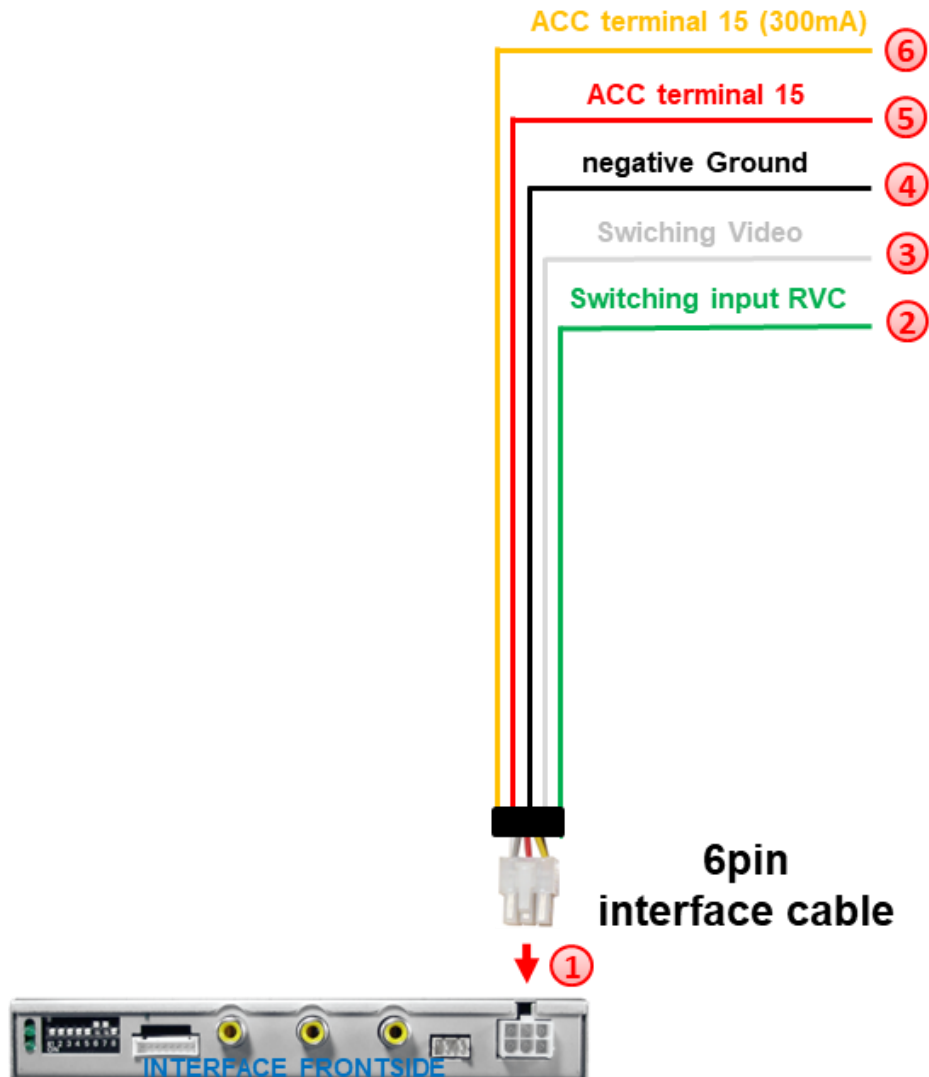

- ① Connect the white female 6pin connector of the 6pin interface cable to the male 6pin connector of the video interface.
- ② Connect the green wire of the 6pin interface cable to +12V of the reverse gear signal. (e.g. reversing light).
- ③ If desired, the white wire of the 6pin interface cable can be used alternatively to the external button to switch the video sources (12V pulse for 2-3 seconds).
- ④ Connect the black wire of the 6pin interface cable to vehicle ground.
- ⑤ Connect the red wire of the 6pin interface cable to +12V ACC terminal 15.
- ⑥ Connect the yellow wire of the 6pin interface cable to +12V ACC (300mA).

Note: The connection of the green wire (Reverse signal) will be described in chapter “After-market rear-view camera”. The white wire, can be used by +12V impulse to switch the enabled video sources , same as the keypad (see chapter “video interface-operation”).

2.4. Connections - head-unit

Remove head-unit.

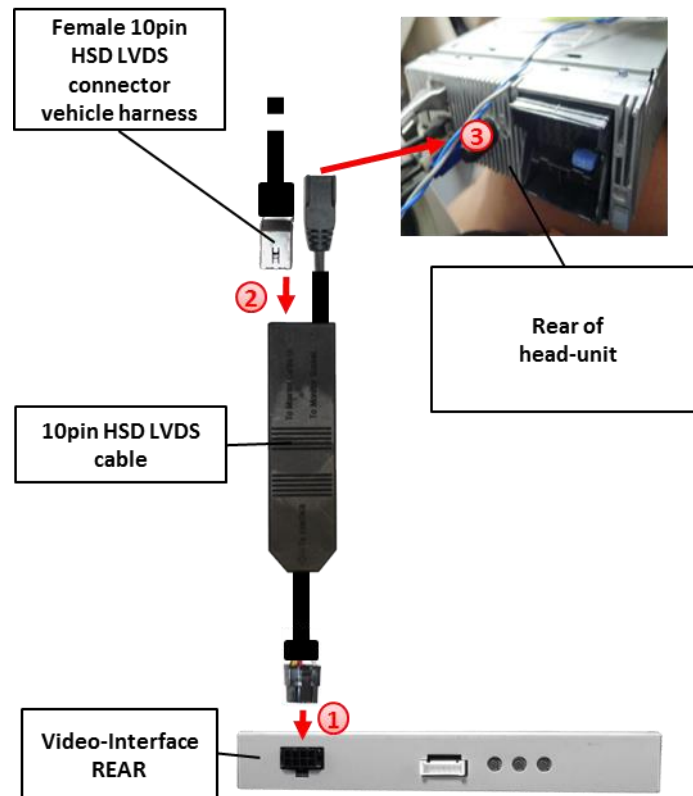

- ① Connect female 10pin Micro-Fit connector of the 10pin HSD LVDS cable to the male 10pin Micro-Fit connector of the video-interface.
- ② Remove female 10pin HSD LVDS connector from the rear of the head-unit and connect it to the LVDS-switch-box of the 10pin HSD LVDS cable.
- ③ Connect female 10pin connector of the 10pin HSD LVDS cable to the male 10pin HSD LVDS connector of the head-unit.

2.5. Connection video sources

It is possible to connect two after-market AV-sources and one after-market rear-view camera to the video-interface.

Before final installation, we recommend a test-run of the interface. Due to changes in the production of the vehicle manufacturer is always the possibility of incompatibility.

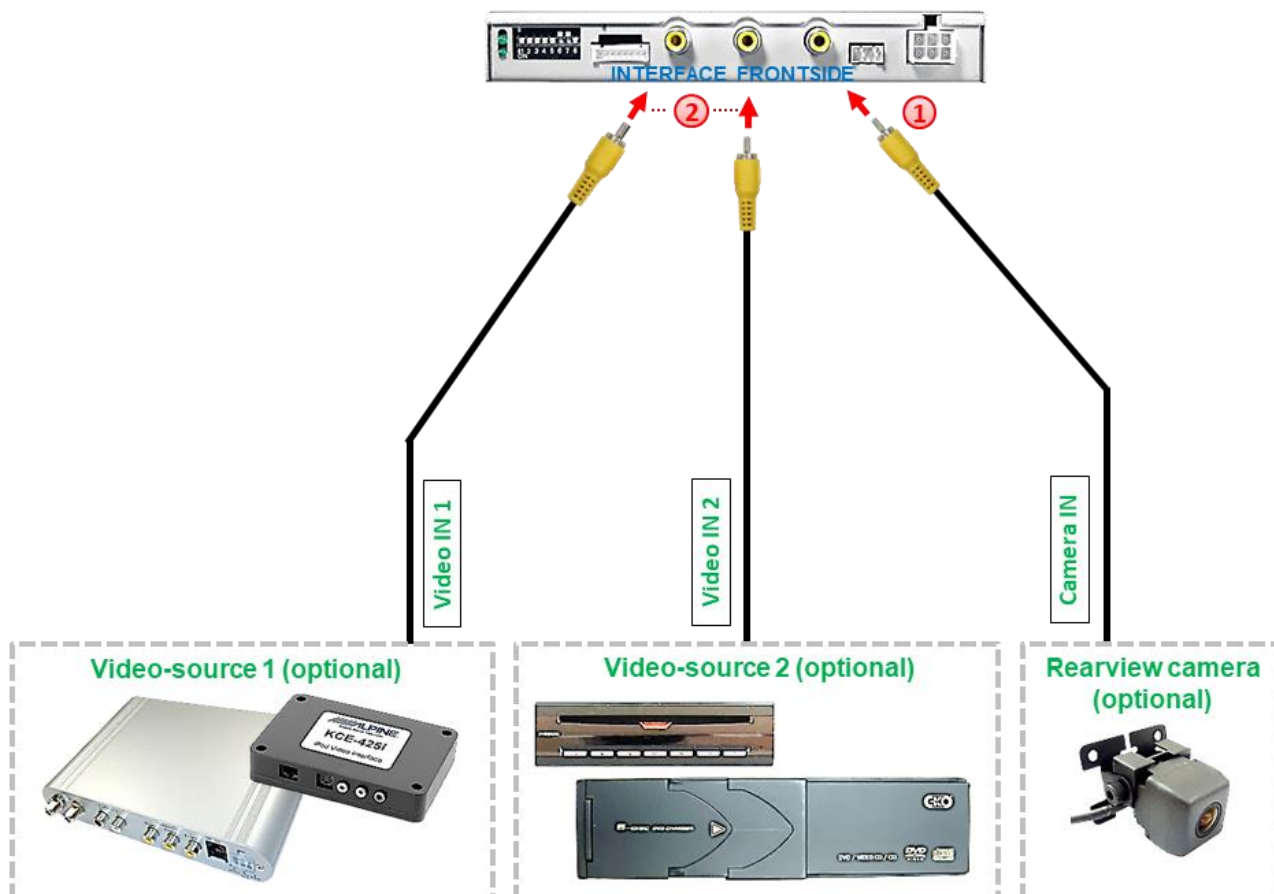

- 1 Connect the rear-view camera's male RCA to the video interface's female RCA „Camera IN”.
- 2 Connect the male RCAs of possibly existing video sources 1 and 2 to the video interface's female RCAs „Video IN1” and „Video IN2”.

2.5.1. Audio-switch and audio insertion

This interface is only able to insert video signals into the factory infotainment and switch audio signals. If an AV-source is connected, audio insertion must be done by factory audio AUX input or FM-modulator. The inserted video-signal can be activated simultaneously to each audio-mode of the factory infotainment.

Connection of 1 AV source

If only one AV-source shall be connected, it is possible to connect the audio output of the AV-source directly to the point of audio-insertion (e.g. to the factory AUX input).

Connection of 2 AV sources

This interface has an integrated audio switch for switching the audio signals. If two AV sources are connected, the audio output of the AV sources is connected to the point of audio-insertion via the optionally available audio cable CAB-FV-AUDIO (e.g. to the factory AUX input). When switching the video interface from AV1 to AV2, the audio signal is also switched automatically.



Attention: The audio cable CAB-FV-AUDIO shown in the diagram is not included in the delivery contents and is optionally available!

Pin-assignment white 12pin insert of the vehicle's Quadlock

Cable colour	Assignment
● Yellow	Audio left Pin 4
● Blue	Audio right Pin 3
● Brown	Ground Pin 5

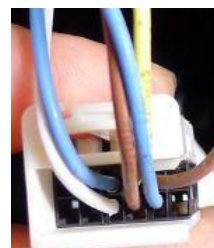

No liability for vehicle wire colors and pin definition! Possible changes by the vehicle manufacturer. The given information must be verified by the installer.

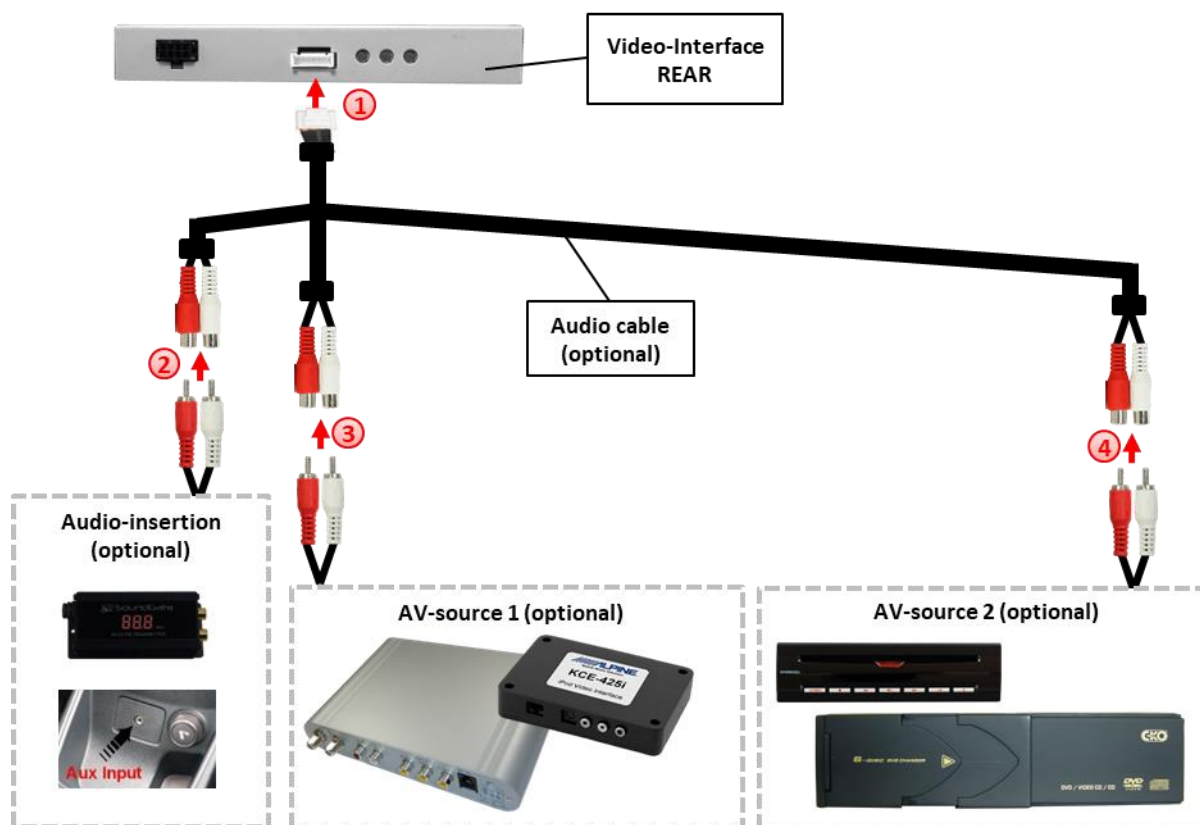

- ① Connect female 7pin connector of the audio cable to male 7pin connector of the video-interface.
- ② Connect the audio-RCA of the possibly existing factory AUX-input or the FM-modulator to the female RCA port AV-Out of the audio cable.
- ③ Connect the audio-RCA of the AV-source 1 to the female RCA port AV1 of the audio cable.
- ④ Connect the audio-RCA of the AV-source 2 to the female RCA port AV2 of the audio cable.

Pin definition 7pin connector

Audio pins	Definition
1/2	Audio input signal R/L of source AV2
3/4	Audio input signal R/L of source AV1
5/6	Audio output signal R/L for factory audio AUX or FM-modulator
7	Ground



Attention: The audio cable CAB-FV-AUDIO shown in the diagram is not included in the delivery contents and is optionally available!

2.5.2. After-market rear-view camera

Note: Do not forget to set dip5 of video-interface to ON before testing.

To switch to the rear-view camera when reverse gear is engaged, an external switching signal from the reverse gear light is required. As the reverse gear light signal contains electronic interference, a traditional open relay (e.g AC-RW-1230 with wiring AC-RS5) or filter (e.g. AC-PNF-RVC) is required. Below schema shows the use of a relay (normally open).

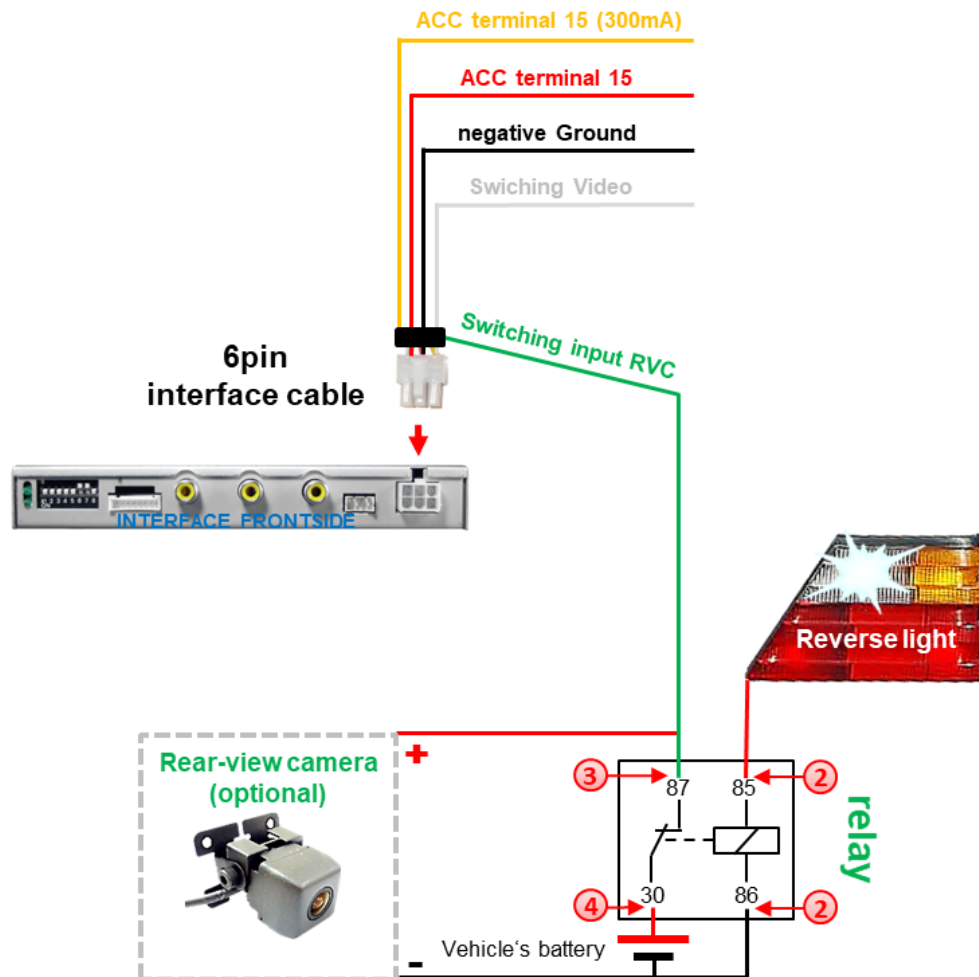

- 1 Connect the green **switching input cable** to the output connector (87) of the relay.
- 2 Connect the Reverse light's power-cable to coil (85) and the vehicle's ground to coil (86) of the relay.
- 3 Connect the output connector (87) of the relay to the rear-view camera's power-cable, like you did it to the green **switching input cable** before.
- 4 Connect stabile and permanent +12V to the relay's input connector (30).

Note: Picture settings for CAM input must be done in AV2.

2.6. Connection – external keypad

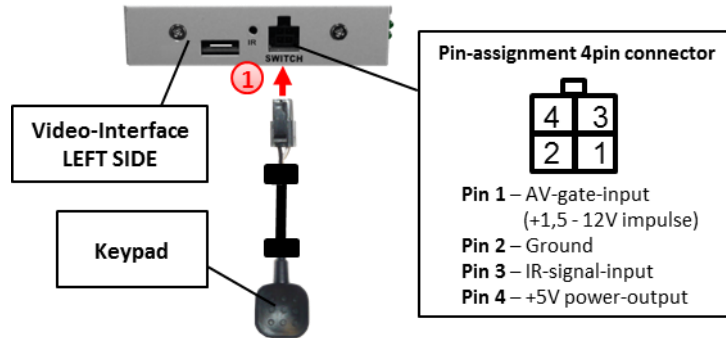

- 1 Connect the female 4pin connector of the keypad to the male 4pin connector of the video-interface.

2.6. Picture settings

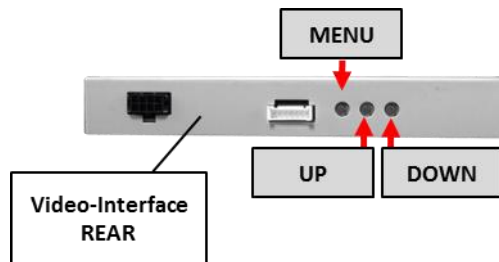

The picture settings can be adjusted by the 3 buttons on the video-interface. Press the MENU button to open the OSD settings menu or to switch to the next menu item. Press UP and DOWN change the selected value. The buttons are embedded in the housing to avoid accidental changes during or after installation. Picture settings must be done separately for RGB, AV1 and AV2 while the corresponding input is selected and visible on the monitor. AV2 and CAM share the same settings which must be adjusted in AV2.

Note: The OSD menu is only shown when a working video source is connected to the selected video-input of the interface.

The following settings are available:

- Contrast
- Brightness
- Saturation
- Sharpness
- DVD – no function
- Tuner – no function
- Navi – no function

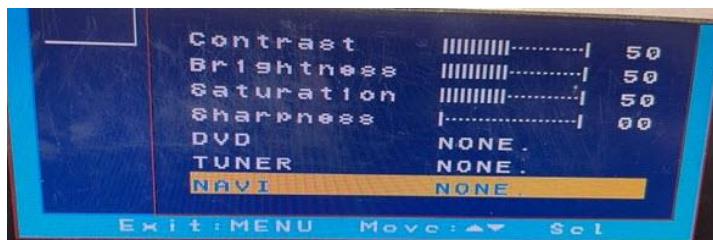

3. Interface operation

The external keypad can be used to switch the enabled inputs.

Long press (2-3 seconds) will switch the video source. Each repetition will switch to the next enabled input. If all inputs are enabled the order is

Factory video → RGB-in → video IN1 → video IN2 → factory video →...

Inputs which are not enabled are skipped. If the audio cable is connected, when switching from video IN1 to video IN2, also the sound will be switched.

Note: The white wire of the 6pin cable can be used with a +12V pulse to switch the video-sources alternatively.

4. Specifications

BATT/ACC range	7V - 25V
Stand-by power drain	30mA
Power	190mA
Video input	0.7V - 1V
Video input formats	NTSC
RGB-video amplitude	0.7V with 75 Ohm impedance
Temperature range	-40°C to +85°C
Dimensions video-box	158 x 22 x 102 mm (W x H x D)

5. FAQ – Trouble shooting Interface functions

For any troubles which may occur, check the following table for a solution before requesting support from your vendor.

Symptom	Reason	Possible solution
No picture/black picture (factory picture).	Not all connectors have been reconnected to factory head-unit or monitor after installation.	Connect missing connectors.
	No power on CAN-bus box (all LED CAN-bus box are off).	Check power supply of CAN-bus box. Check CAN-bus connection of CAN-bus box.
	CAN-bus box connected to CAN-bus in wrong place.	Refer to the manual where to connected to the CAN-bus. If not mentioned, try another place to connect to the CAN-bus.
	No power on video-interface (all LED video-interface are off).	Check whether CAN-bus box delivers +12V ACC on red wire output of 8pin to 6pin cable. If not cut wire and supply ACC +12V directly to video-interface.
No picture/black picture/white picture (inserted picture) but factory picture is OK.	No picture from video source.	Check on other monitor whether video source is OK.
	No video-source connected to the selected interface input.	Check settings dips 1 to 3 of video interface which inputs are activated and switch to corresponding input(s).
	LVDS cables plugged in wrong place.	Double-check whether order of LVDS cables is exactly connected according to manual. Plugging into head-unit does not work when the manual says to plug into monitor and vice versa.
Inserted picture totally wrong size or position.	Wrong monitor settings of video-interface.	Try different combinations of dips 7 and 8 of video-interface. Unplug 6pin power after each change.
Inserted picture double or 4 times on monitor.		
Inserted picture distorted, flickering or running vertically.	Video sources output set to AUTO or MULTI which causes a conflict with the interfaces auto detection.	Set video source output fixed to PAL or NTSC. It is best to set all video sources to the same standard.
	If error occurs only after source switching: Connected sources are not set to the same TV standard.	Set all video sources to the same standard.
	Some interfaces can only handle NTSC input.	Check manual whether there is a limitation to NTSC mentioned. If yes, set source fixed to NTSC output.
Inserted picture b/w.	Picture settings have not been adjusted.	Use the 3 buttons and the interface's OSD to adjust the picture settings for the corresponding video input.
Inserted picture qual. bad.		
Inserted picture size slightly wrong.		
Inserted picture position wrong.		
Camera input picture flickers.	Camera is being tested under fluorescent light which shines directly into the camera.	Test camera under natural light outside the garage.
Camera input picture is bluish.	Protection sticker not removed from camera lens.	Remove protection sticker from lens.

Symptom	Reason	Possible solution
Camera input picture black.	Camera power taken directly from reverse gear lamp.	Use relay or electronics to "clean" reverse gear lamp power. Alternatively, if CAN-bus box is compatible with the vehicle, camera power can be taken from green wire of 6pin to 8pin cable.
Camera input picture has distortion.		
Camera input picture settings cannot be adjusted.	Camera input picture settings can only be adjusted in AV2 mode.	Set dip 3 of video-interface to ON (if not input AV2 is not already activated) and connect the camera to AV2. Switch to AV2 and adjust settings. Reconnect camera to camera input and deactivate AV2 if not used for other source.
Graphics of a car in camera input picture.	Function PDC is ON in the interface OSD.	In compatible vehicles, the graphics will display the factory PDC distance. If not working or not wanted, set interface OSD menu item UI-CNTRL to ALLOFF.
Chinese signs in camera input picture	Function RET or ALL is ON (function for Asian market) in the interface OSD.	Set interface OSD menu item UI-CNTRL to ALLOFF or PDCON.
Not possible to switch video sources by OEM button.	CAN-bus interface does not support this function for vehicle.	Use external keypad or cut white wire of 6pin to 8pin cable and apply +12V impulses for AV-switching.
Not possible to switch video sources by external keypad.	Pressed too short.	For video source switching a longer press of about 2.5 seconds is required.
	SW-version of interface does not support external keypad.	Use OEM-button or cut white wire of 6pin to 8pin cable and apply +12V impulses for AV-switching.
Interface does not switch to camera input when reverse gear is engaged.	CAN-bus interface does not support this function for the vehicles.	Cut the green wire of the 6pin to 8pin cable and apply +12V constant from reverse gear-lamp signal. Use relay to "clean" R-gear lamp power.
Interface switches video-sources by itself.	CAN-bus interface compatibility to vehicle is limited.	Cut the grey wire of 6pin to 8pin and isolate both ends. If problem still occurs, additionally cut the white wire of 6pin to 8pin cable and isolate both ends.

6. Technical Support

Please note that direct technical support is only available for products purchased directly from NavLinkz GmbH. For products bought from other sources, contact your vendor for technical support.

NavLinkz GmbH
distribution/tech dealer-support
 Heidberghof 2
 D-47495 Rheinberg

Tel +49 2843 17595 00
 Email mail@navlinkz.de

 10R-03 5384

Made in China

