

## Video-inserter

### VL2-PCM31

## Compatible with PORSCHE vehicles with PCM 3.1 infotainment

Video-inserter with 2 video inputs and 1 rear-view camera input with CAN control



example PCM 3.1

### Product features

- Video-inserter for factory-infotainment systems
- 2 video-inputs for after-market devices (e.g. DVD-Player, DVB-T tuner)
- Built-in audio-switch (no audio-insertion)
- Rear-view camera video-input
- Automatic switching to rear-view camera input on engagement of the reverse gear
- Activatable parking guide lines for rear-view camera (not for all vehicles available)
- Video-in-motion (ONLY for connected video-sources)
- Video-inputs NTSC compatible

## Contents

### 1. Prior to installation

- 1.1. Delivery contents
- 1.2. Checking the compatibility of vehicle and accessories
- 1.3. Boxes and connectors
  - 1.3.1. Video-Interface
  - 1.3.2. CAN-bus box
  - 1.3.3. Dip-switch settings – interface (black)
    - 1.3.3.1. Enabling the interface's video inputs (dip 2-3)
    - 1.3.3.2. Rear-view camera setting (dip 5)

### 2. Installation

- 2.1. Place of installation
  - 2.1.1. Place of Installation – video interface and Can-Bus box
  - 2.1.2. Place of Installation – daughter PCB
- 2.2. Connection schema
- 2.3. Opening the factory head unit
- 2.4. Connection-50pin ribbon cables – daughter PCB
  - 2.4.1. Warning notes, concerning the installation of ribbon cables
- 2.5. Connection and cable laying of the picture signal cable – head unit
- 2.6. Reassembling the head unit's housing parts
- 2.7. Connection of the picture signal cable – video interface
- 2.8. Connecting video-interface – Power/CAN
- 2.9. Connection video-interface – analogue
- 2.10. Connection – video sources
- 2.11. Audio-switch and audio-insertion
- 2.12. After-market rear-view camera
  - 2.12.1. . Case 1: CAN-box receives the reverse gear signal
  - 2.12.2. . Case 2: CAN-box does not receive the reverse gear signal
- 2.13. Connecting video-interface - external keypad
- 2.14. Picture settings and guide lines

### 3. Video interface operation

- 3.1. By infotainment button
- 3.2. By external keypad or white wire of the 6pin cable

### 4. Specifications

### 5. FAQ – Trouble Shooting-Interface functions

### 6. Technical support

## Legal Information

By law, watching moving pictures while driving is prohibited, the driver must not be distracted. We do not accept any liability for material damage or personal injury resulting, directly or indirectly, from installation or operation of this product. Apart from using this product in an unmoved vehicle, it should only be used to display fixed menus or rear-view-camera video when the vehicle is moving (for example the MP3 menu for DVD upgrades).

Changes/updates of the vehicle's software can cause malfunctions of the interface. Up to one year after purchase we offer free software-updates for our interfaces. To receive a free update, the interface has to be sent in at own cost. Wages for de-and reinstallation and other expenditures involved with the software-updates will not be refunded.

No liability for vehicle wire colours and pin definition!

Changes by the vehicle manufacturer are possible. The given information has to be verified by the installer.

## 1. Prior to installation

Read the manual prior to installation. Technical knowledge is necessary for installation. The place of installation must be free of moisture and away from heat sources.

### 1.1. Delivery contents

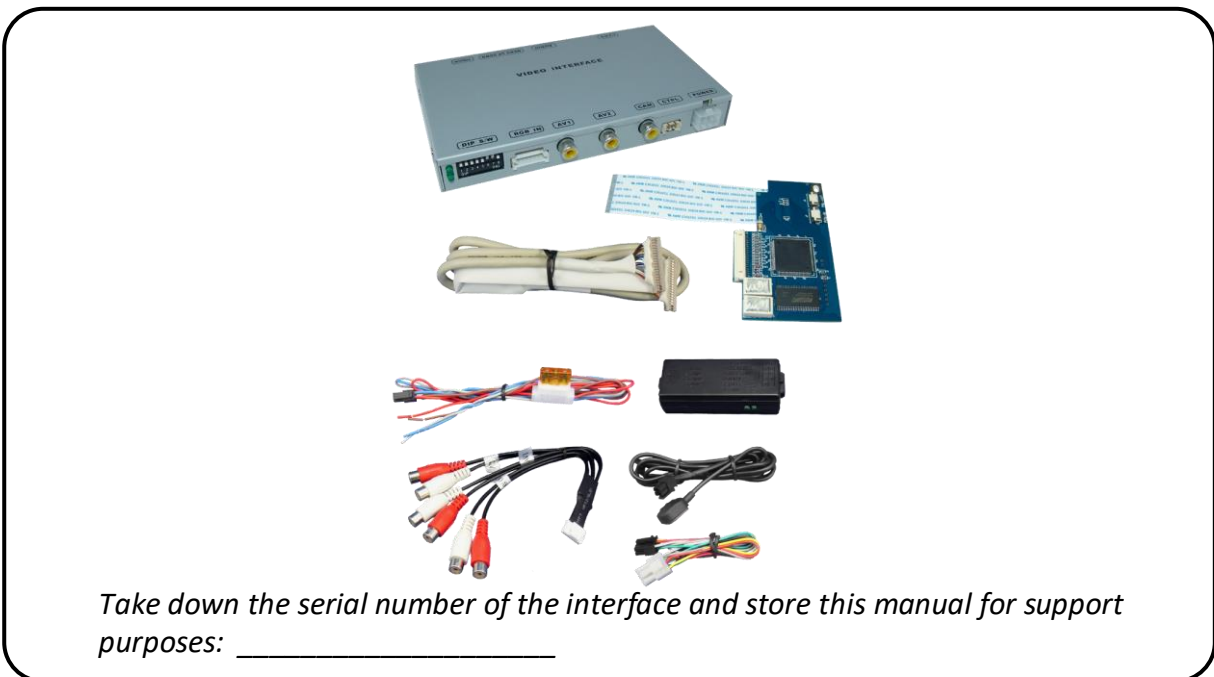

## 1.2. Checking the compatibility of vehicle and accessories

Requirements		
Brand	Compatible vehicles	Compatible systems
<b>Porsche</b>	911 (991) model year 2011-2015 Boxster (981) model year 2012-2015 Cayenne E2 (92A) model year 2011-2015 Cayman (981c) model year 2013-2016 Macan model year 2013-2014 Panamera (970) model year 2009-2016	PCM 3.1
<b>Limitations:</b>		
<i>Video only</i>	The interface inserts ONLY video signals into the infotainment. For inserting Audio signals either the possibly existing factory audio-AUX-input or a FM-modulator can be used.	
<i>Factory rear-view camera</i>	Automatically switching-back from inserted video to factory rear-view camera is only possible while the reverse gear is engaged. To delay the switch-back an additional electronic part is required.	
<i>Guidelines</i>	Displayed guidelines are not available in all vehicles.	
<i>Video input signal</i>	NTSC video sources compatible only.	

## 1.3. Boxes and connectors

### 1.3.1. Video Interface

The video-interface converts the video signals of connected after-market sources in a factory monitor compatible picture signal which is inserted in the factory monitor, by using separate trigger options. Further it reads the vehicle's digital signals out of the vehicle's CAN-bus and converts them for the video interface.

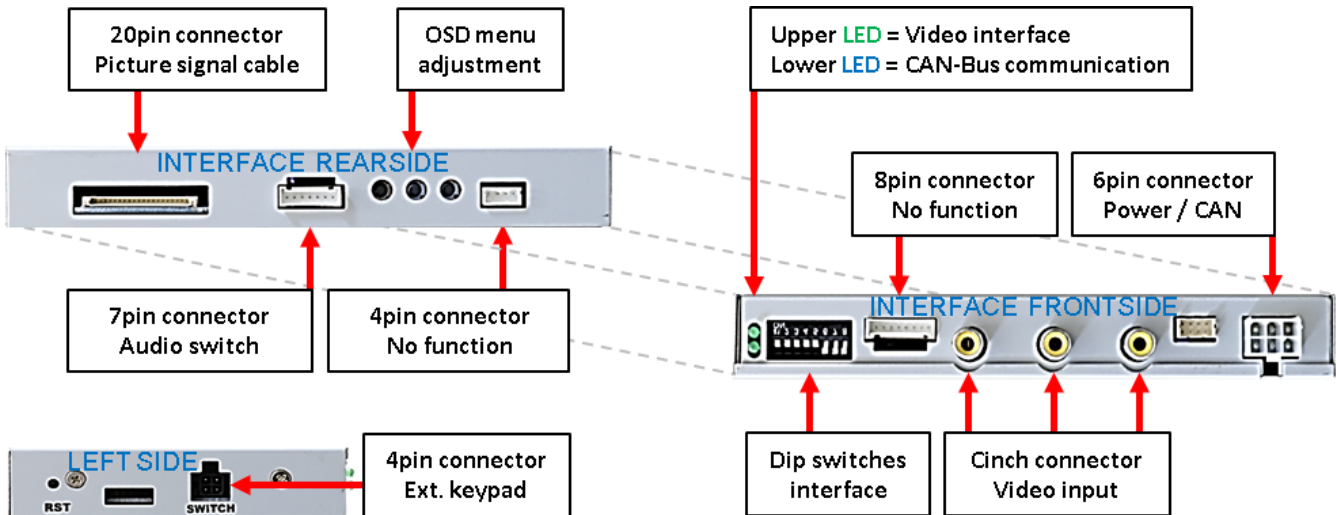

### 1.3.2. CAN-bus box

The CAN box reads the vehicle's digital signals out of the vehicle's CAN-bus and converts them for the video interface.

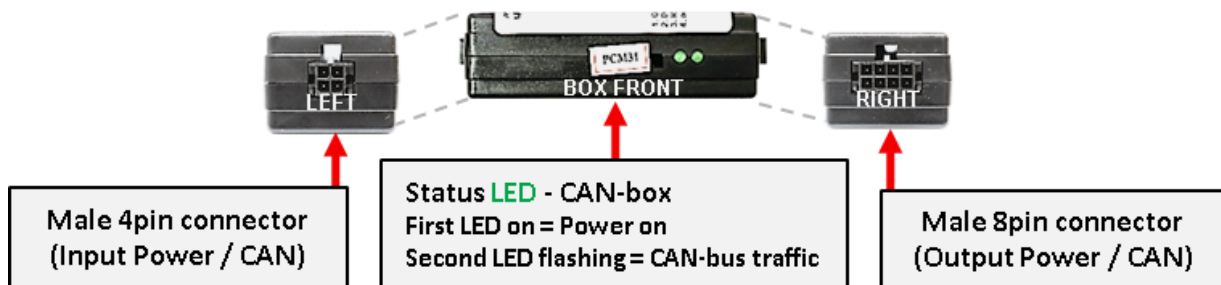

### 1.3.3. Dip-switch settings – interface (black)

Some settings have to be selected by the dip-switches on the video interface. Dip position down is ON and position up is OFF.



Dip	Function	ON (down)	OFF (up)
1	No function		set to OFF
2	CVBS AV1-input	enabled	disabled
3	CVBS AV2-input	enabled	disabled
4	No function		set to OFF
5	Rear-view cam type	after-market	factory or none
6	Monitor specific adjustments		set to OFF
7			
8			

**After each Dip-switch-change a power-reset of the Can-box has to be performed!**

See the following chapters for detailed information.

#### 1.3.3.1. Enabling the interface's video inputs (dip 2-3)

Only the enabled video inputs can be accessed by switching through the interface's video sources. It is recommended to enable only the required inputs, because the disabled inputs will be skipped while switching through the video interfaces inputs.

#### 1.3.3.2. Rear-view camera setting (dip 5)

If set to OFF, the interface switches to factory LVDS picture while the reverse gear is engaged to display factory rear-view camera or factory optical park system picture.

If set to ON, the interface switches to its rear-view camera input while the reverse gear is engaged.

#### 1.3.3.3. Monitor selection (dip6, 7-and 8)

Set to OFF

**Note:** Dip 1 and 4 are out of function and have to be set to **OFF**.

## 2. Installation

To install the interface, first switch off the ignition and disconnect the vehicle's battery. Please read the owner's manual of the car, regarding the battery's disconnection! If required, enable the car's sleep-mode (hibernation mode)

In case the sleep-mode does not succeed, the disconnection of the battery can be done with a resistor lead.

If the necessary stabilized power supply for the interface is not taken directly from the battery, the chosen connection has to be checked for being constantly stable.

The interface needs a permanent 12V source!

### 2.1. Place of installation

#### 2.1.1. Place of installation – video interface und CAN-Bus box

The boxes shall be installed behind the vehicle's head-unit or the glove department, depending on equipment and space.

#### 2.1.2. Place of installation - daughter PCB

The interface's daughter PCB is prepared to be installed in the head unit's housing.

### Internal PCB installation





## 2.2. Connection schema

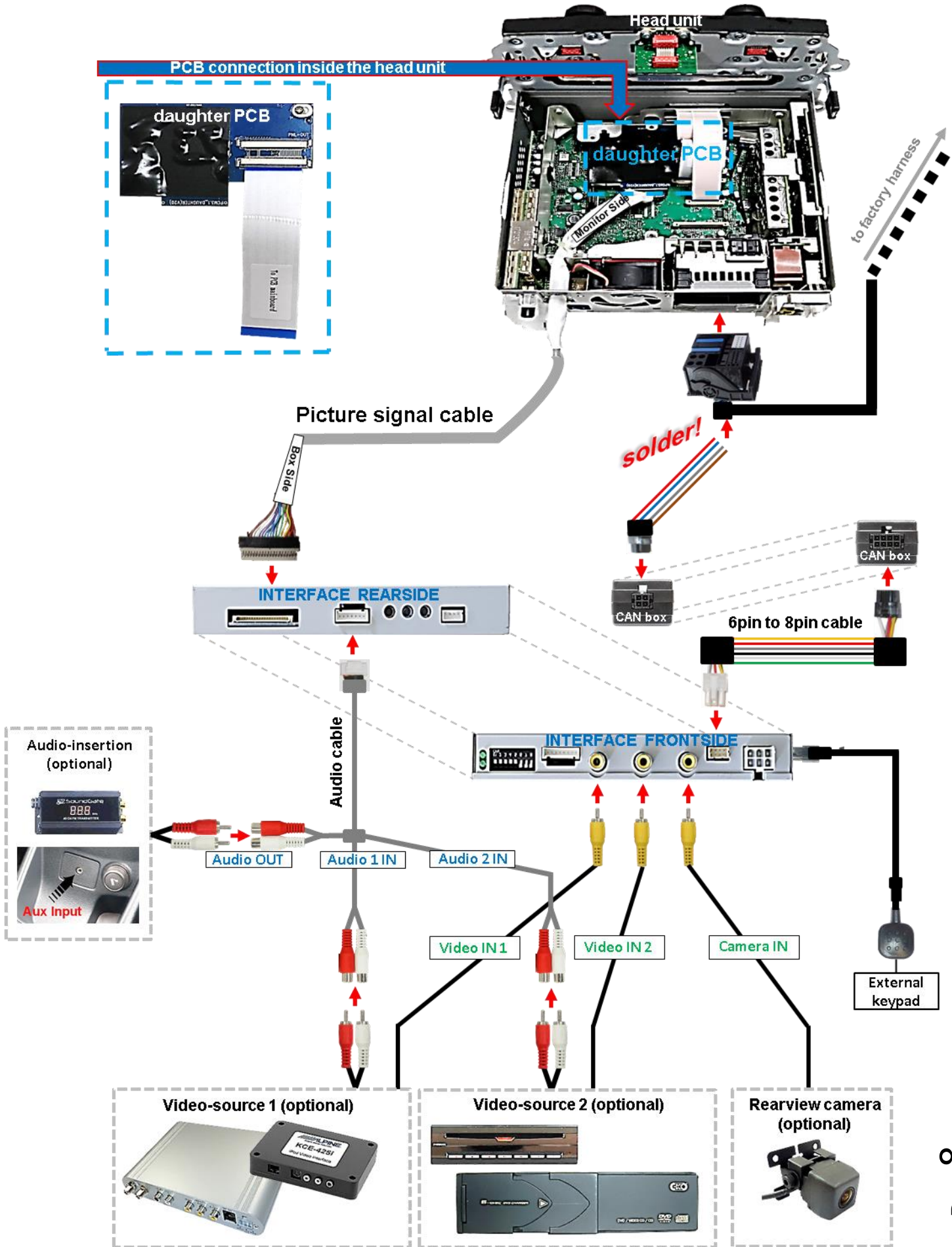



## 2.3. Opening the factory head unit

Remove the vehicle's head-unit.



- 1 Turn out both Torx screws of the head unit's bottom part of the head unit (red arrows) and both Torx screws at the upper part of the head unit.

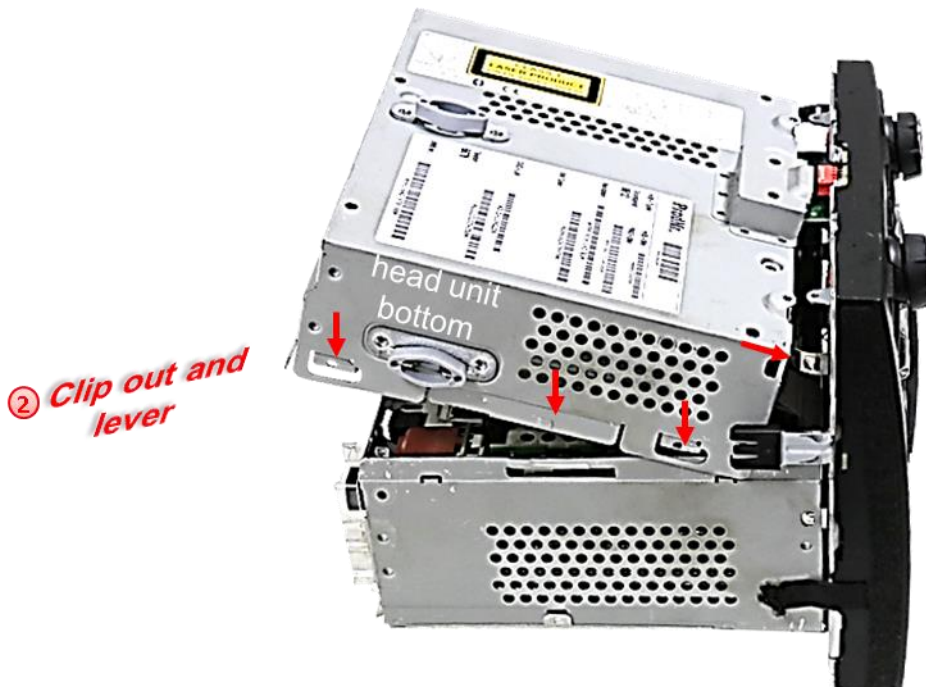

- 2 Clip out and lever the fixing points of the head unit's upper and lower housing parts (red arrows) all around the housing and carefully separate both parts.



**Pay attention to sensitive cable connections between the parts and disconnect before separating!**

## 2.4. Connection-50pin ribbon cables -

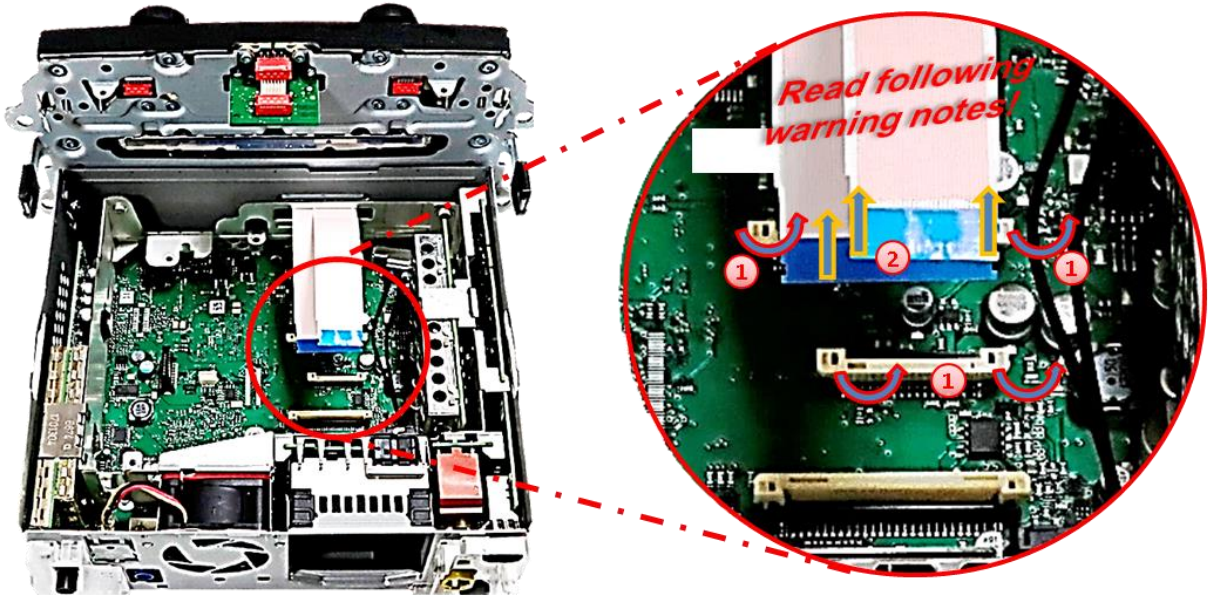

- 1 Push upwards the white hinges of the factory ribbon cable bases to unlock the original 50pin and 30pin ribbon cables of the factory PCB (red arrows)
- 2 Carefully pull out both original ribbon cables (yellow arrows).

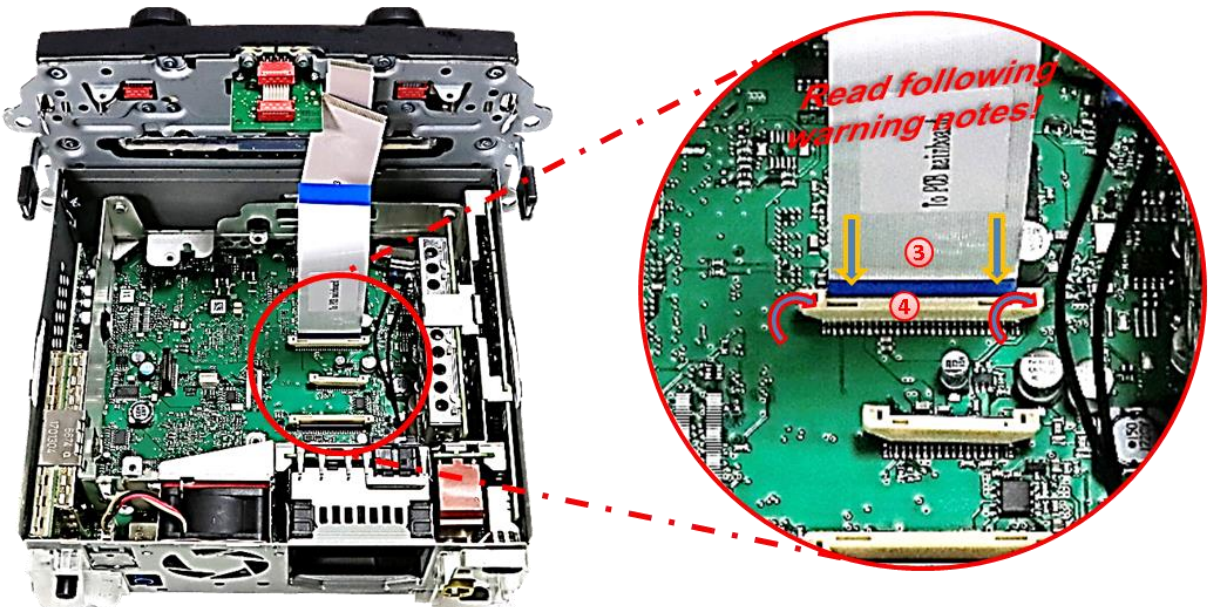

- 3 Connect the daughter PCB's 50pin ribbon cable „**To PCB mainboard**“ to the previously become free 50pin ribbon cable base of the factory PCB. Make sure that the connector pins are faced in the invisible direction.
- 4 After a check of its perfect position, close the ribbon cable base's lock by pushing downwards the white hinge, to fix the connection again.



- 1 As shown in the picture, bring the daughter PCB in position and fix it to the mainboard by using the enclosed brass spacer.
- 2 In case that the daughter PCB's 50pin ribbon cable had been disconnected before, reconnect it and fix it with the black lock hinge at the ribbon cable base.

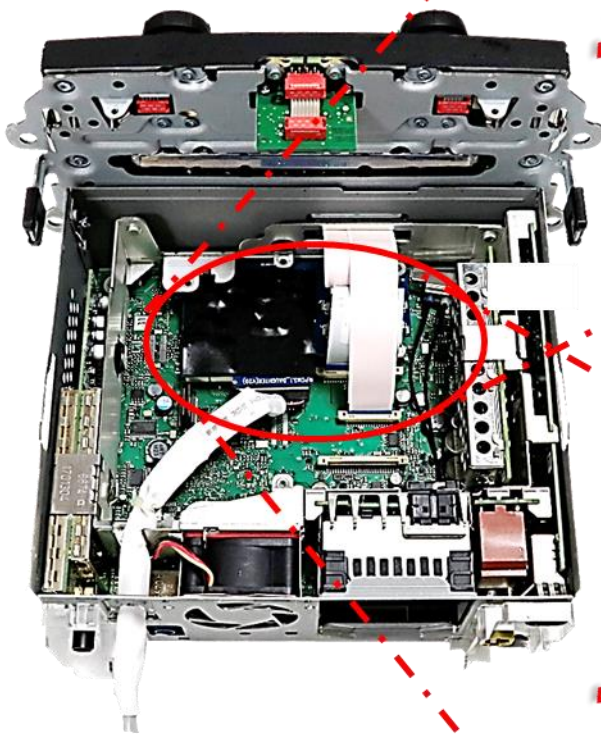
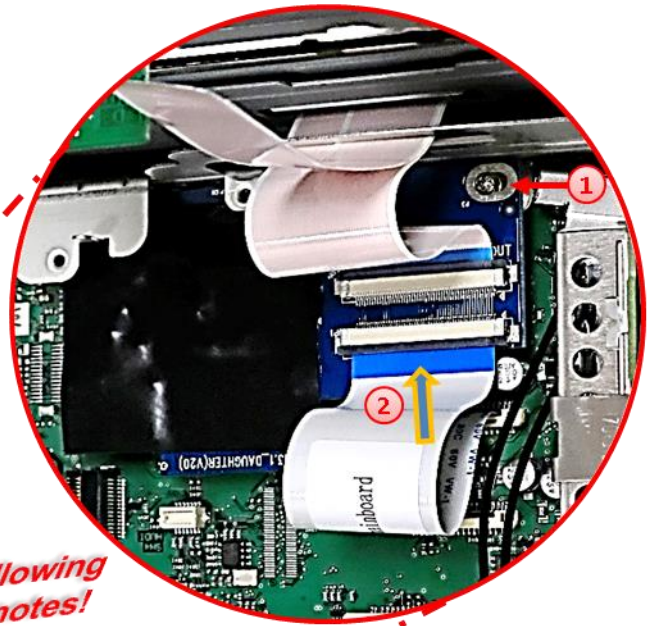

*Read following warning notes!*

- 3 Reconnect the original 30pin ribbon cable to the mainboard's 30pin ribbon cable base.
- 4 After a check of its perfect position, close the ribbon cable base's lock by pressing the black hinge, to save the connection again.

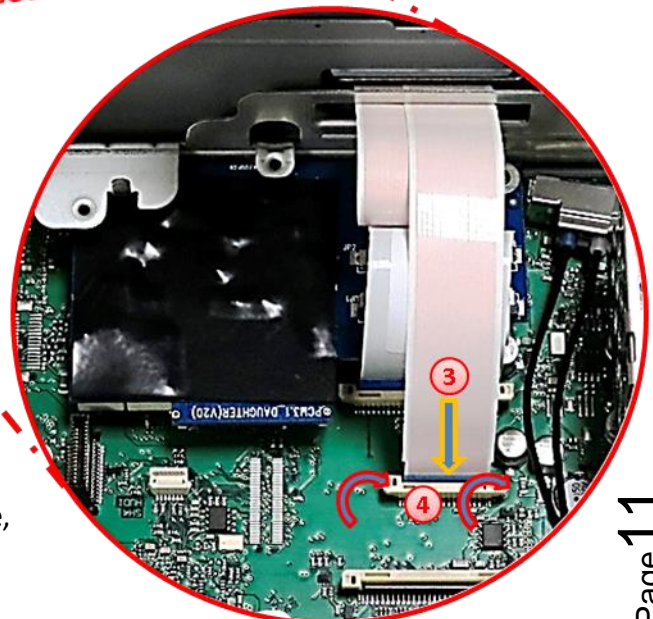

## 2.4.1. Warning notes, concerning the installation of ribbon cables

- 1) The contacting ends of ribbon cables always have to be installed in a straight and precise 180° position to the connector. Each deviation from a perfect contact position will cause faulty contact and even danger of short circuit
- 2) The ribbon cable's contacting side always has to correspond to the contacting side of the connector, concerning the mounting position.
- 3) Avoid cable contusion or cable injury caused by sharp-edged metal.

## 2.5. Connection and cable laying of the picture signal cable – head unit

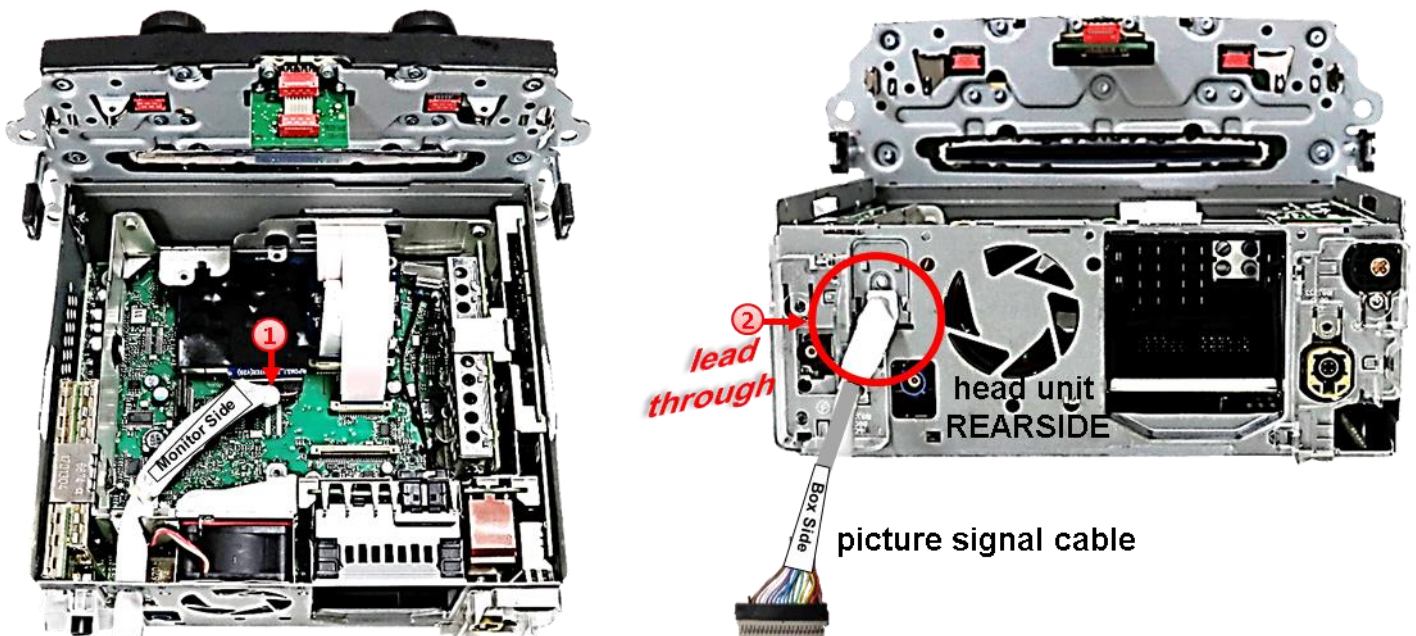

- 1 Connect the picture signal cable's female 20pin connector „ **MONITOR SIDE**“ with its contacting side in down position to the 20pin connector of the installed daughter PCB inside the head unit.



Take care for installing the picture signal cable in the right direction, as both connectors seem to be identical. (Pay attention to the cable's caption "**MONITOR SIDE**" and "**BOX SIDE**")

- 2 Lead the connected picture signal cable out of the head unit at the location that's shown in the picture and save it against cable damage.



## 2.6. Reconnection of the head unit's housing parts

① clip in  
and  
screw in

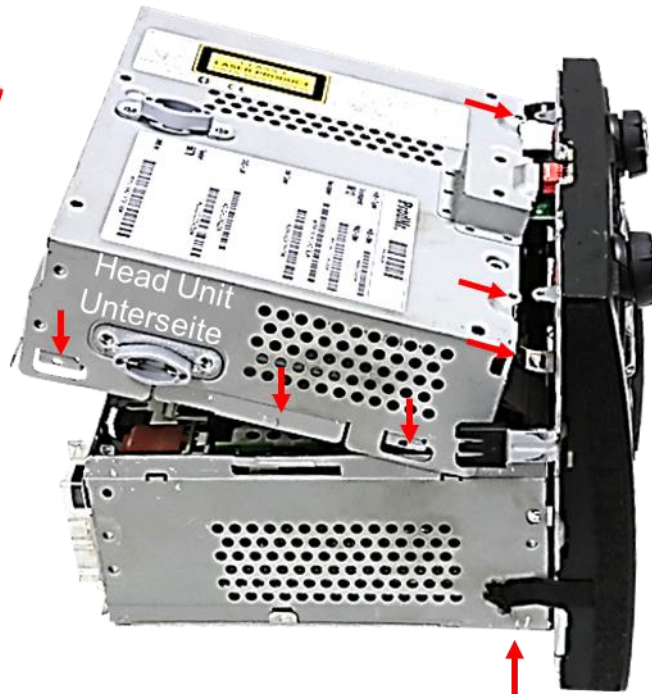

- ① Clip in the head unit housing's mounting locations and again fix the parts to the monitor by using the 4 original Torx screws.

## 2.7. Connection of the picture signal cable

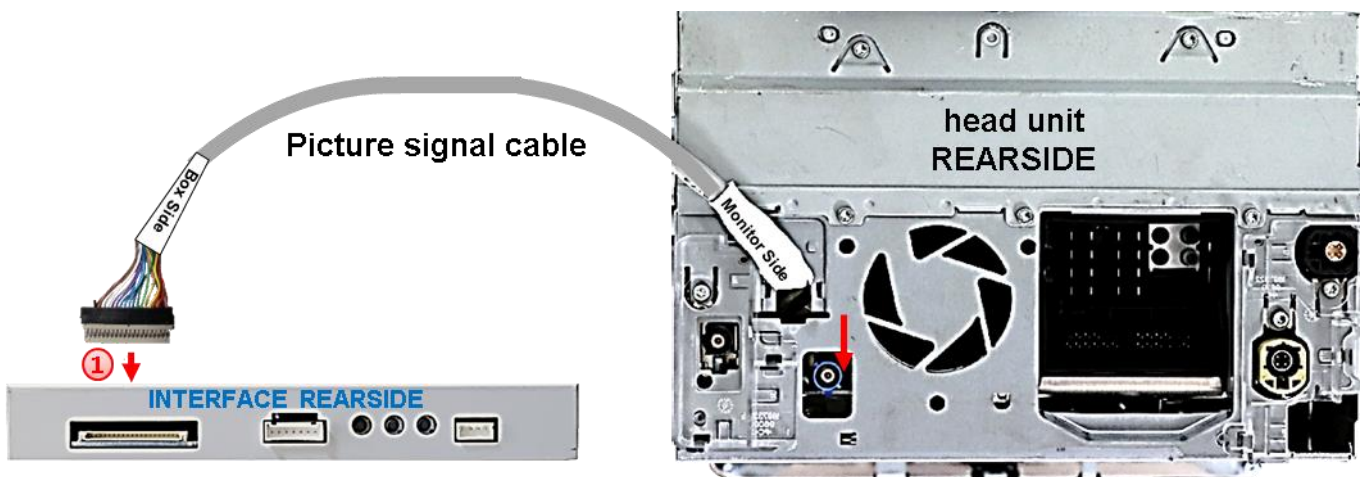

- ① Connect the picture signal cable's female 20pin connector „ **BOX SIDE**“ to the 20pin connector of the video interface, with its contacting side in the UP position.



Take care for installing the picture signal cable in the right direction, as both connectors seem to be identical. (Pay attention to the cable's caption "**MONITOR SIDE**" and "**BOX SIDE**")

## 2.8. Connecting video-interface – Power / CAN

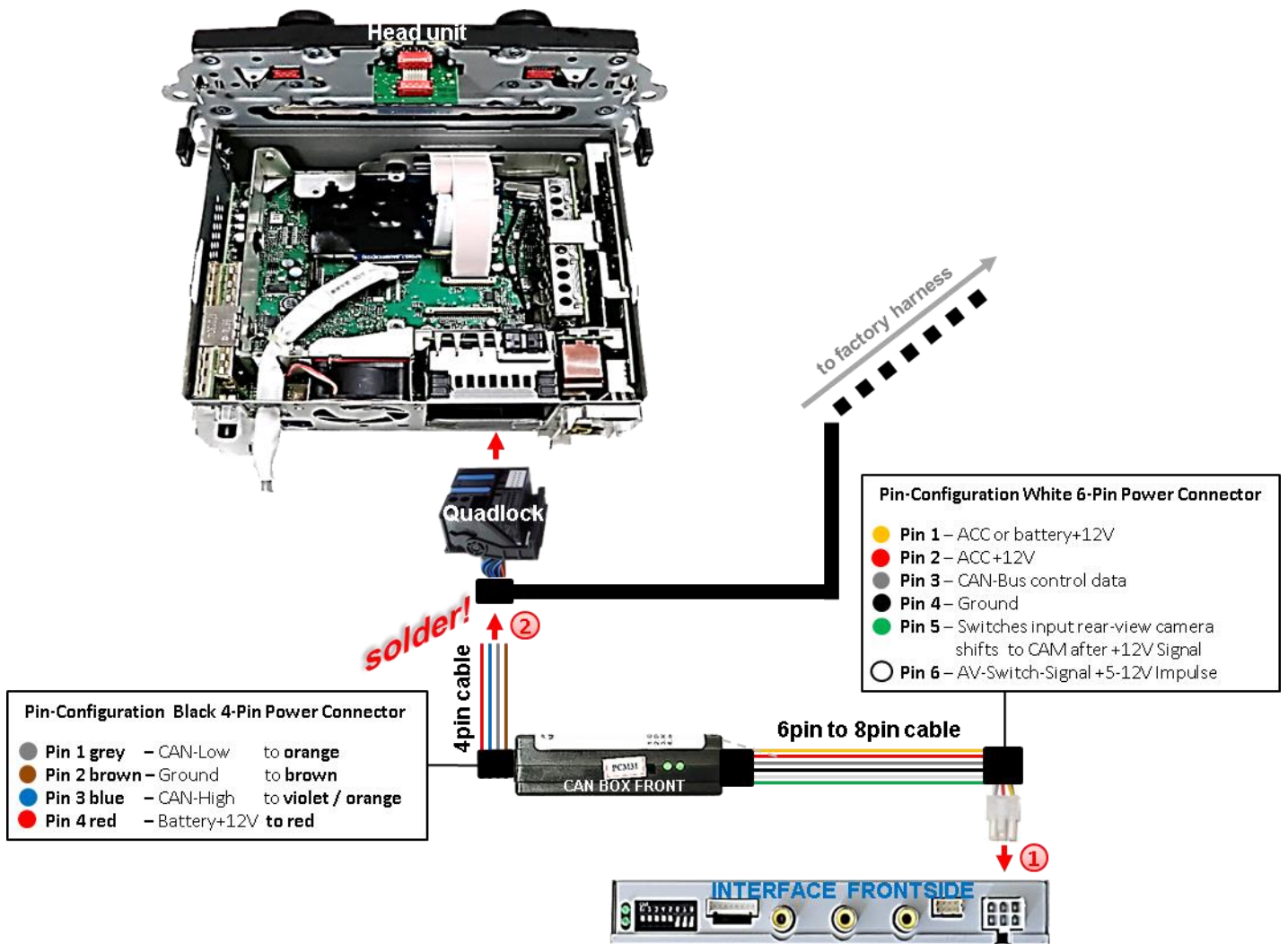

- ① Connect the white female 6pin connector of the 6pin to 8pin cable to the male 6pin connector of the video interface.
- ②
  - 1) Solder the red coloured wire of the 4pin Power / CAN cable to Quadlock's +12V ACC (red) .
  - 2) Solder the brown coloured wire of the 4pin Power /CAN cable to Quadlock's ground (brown).
  - 3) Solder the blue coloured wire of the 4pin Power / CAN cable to Quadlock's **CAN HIGH (violet / orange)**.
  - 3) Solder the grey coloured wire of the 4pin Power CAN cable to Quadlock's **CAN LOW (orange)**.

**Note:** Check the LEDs of the CAN box after reconnecting the battery - one **must** be on, the second one **must** be flashing.

If this is not the case, the interface's analogue connection is required by using the 6pin cable with open wire ends (see following chapter).



## 2.9. Connecting video-interface – analogue

If the communication between the CAN box and the vehicle's CAN bus does not succeed (not all vehicles are compatible), an analogue connection is required by using the 6pin cable with open wire ends.

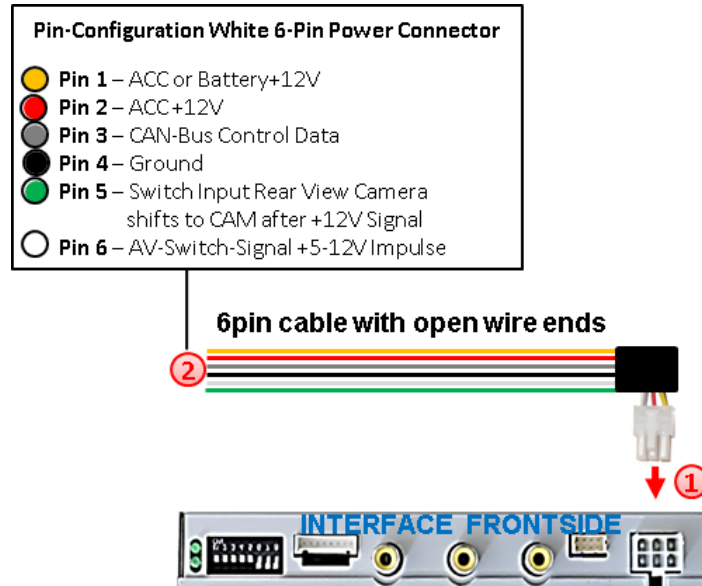

- 1 Connect the female 6pin connector of the 6pin cable to the 6pin connector of the video interface.
- 2 Connect the yellow, the red and the black wire of the 6pin cable to the vehicle's power and ground.

**Note:** The connection of the green wire (Reverse signal) will be described in chapter "After-market rear-view camera". The white wire will be used to switch the enabled video sources (see chapter "video interface – operation"). The grey wire stays unconnected.

## 2.10. Connecting Video-sources

It is possible to connect two after-market video sources and one after-market rear-view camera to the video-interface.

**Before final installation of the peripheral devices, we recommend a test-run to detect a incompatibility of vehicle and interface. Due to changes in the production of the vehicle manufacturer there's always a possibility of incompatibility.**

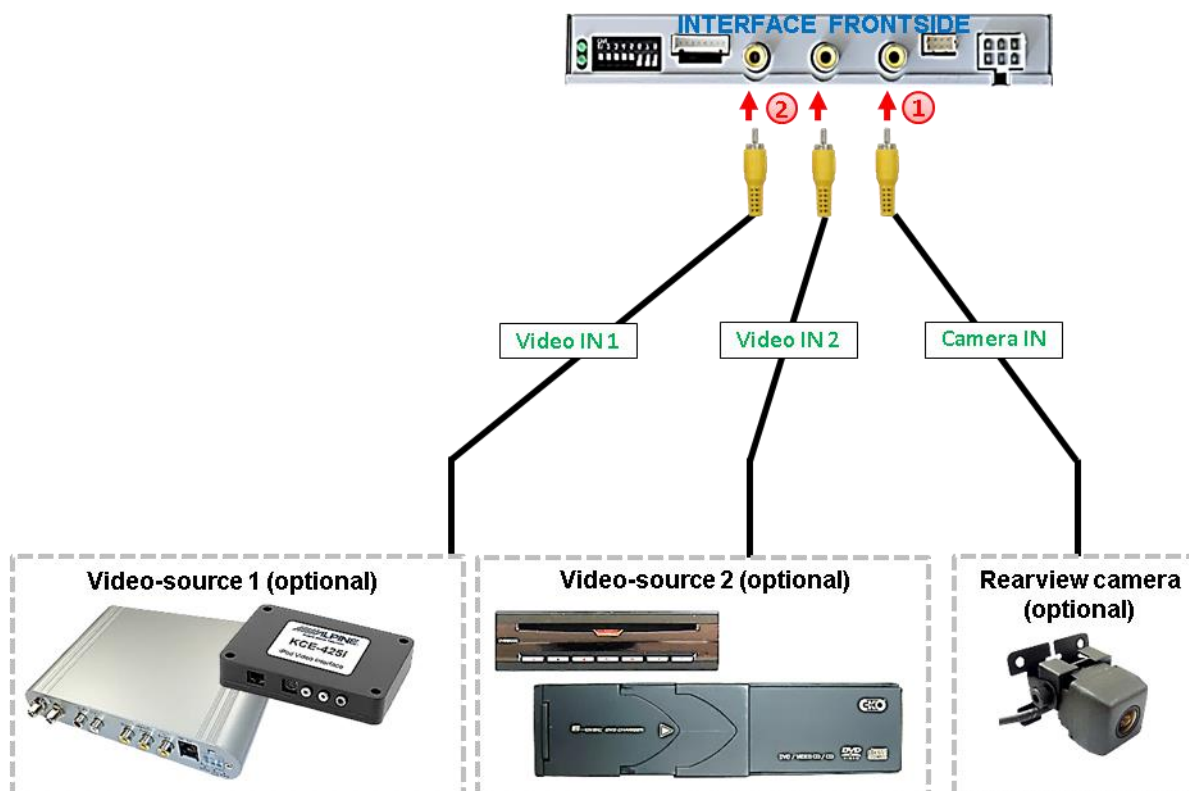

- 1 Connect the rear-view camera's RCA to the female RCA „**Camera IN**“ of the video cable.

**Note:** The picture settings for CAM input have to be adjusted in AV2.

- 2 Connect the RCA of the video source 1 and video source 2 to the female RCA „**Video IN1**“ and „**Video IN2**“ of the video cable.

## 2.11. Audio-switch and audio-insertion

This interface is only able to insert video signals into the factory infotainment and switch audio signals. If an AV-source is connected to AV1 or AV2, audio insertion must be done by factory audio AUX input or FM-modulator to which the interface's sound-switch output is connected. When the interface is switched from AV1 to AV2, the audio signal is switched parallel to the corresponding video signal by the interface's built-in audio-switch. The inserted video-signal can be activated simultaneously to each audio-mode of the factory infotainment.

Audio pins	Definition
1/2	Audio input signal R/L of source AV2
3/4	Audio input signal R/L of source AV1
5/6	Audio output signal R/L for factory audio AUX or FM-modulator
7	Ground

**Note:** If only one AV-source shall be connected, it is possible to connect the audio output of the AV-source directly to the point of audio-insertion (e.g. audio AUX input).

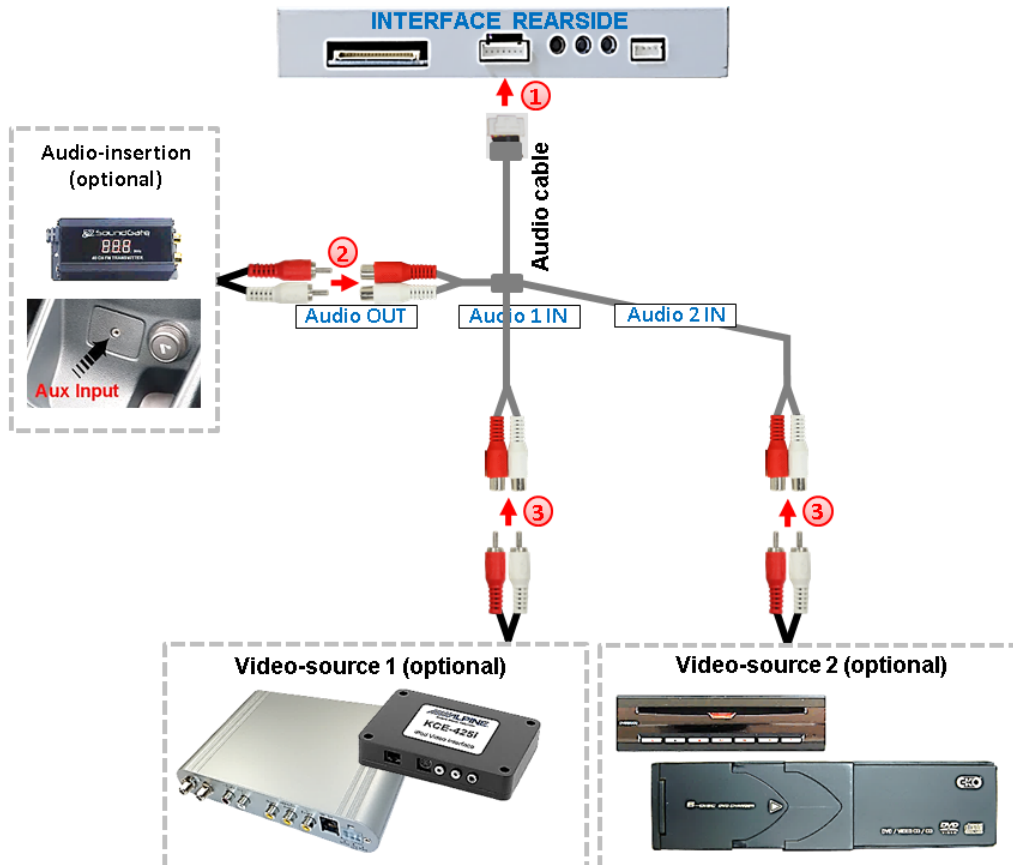

- ① Connect the audio cable's female 7pin connector to the male 7pin connector of the video-interface.
- ② Connect the audio-RCA of the possibly existing factory AUX-input or the FM-modulator to the audio cable's female RCA port "Audio OUT".
- ③ Connect the audio-RCA of AV-source 1 and AV source 2 to the female RCA port of the audio cable's „Audio 1 IN“ und „Audio 2 IN“.

## 2.12. After-market rear-view camera

Some vehicles have a different reverse gear code on the CAN-bus which the included CAN-box is not compatible with. In this case there are two different ways of installation. If the CAN-box is able to detect an enabled vehicle's reverse gear, the green wire of the 6pin to 12pin cable carries +12V while the reverse gear is engaged.

**Note:** Do not forget to set dip5 of video-interface to ON before testing.

### 2.12.1. Case 1: CAN-box receives the reverse gear signal

If the CAN-bus box delivers +12V on the green wire of the 6pin to 12pin cable while reverse gear is engaged, the video interface will automatically switch to the rear-view camera input „CAMERA IN“ while the reverse gear is engaged.

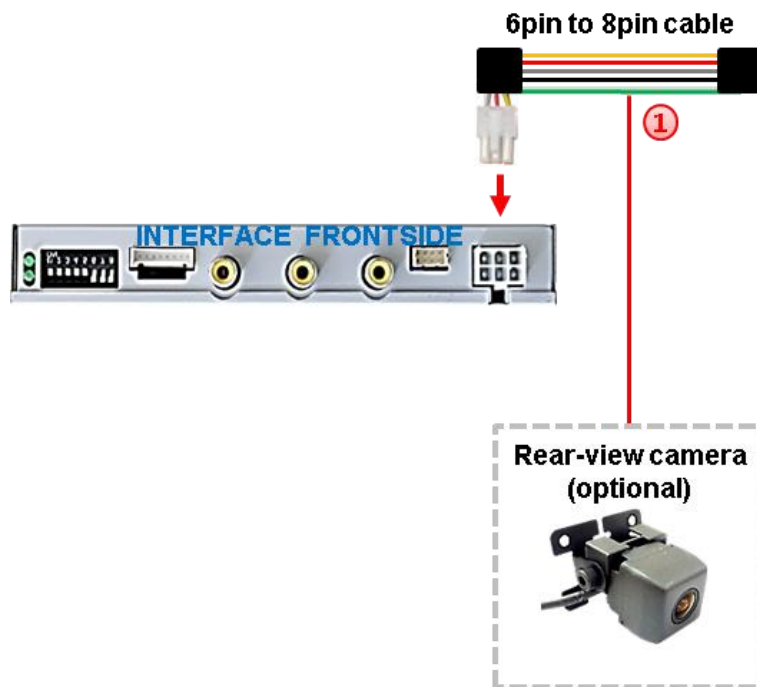

- ① Additionally, the +12V (max. 500mA) power supply for the rear-view camera can be taken from the green wire of the 6pin to 8pin cable.

## 2.12.2. . Case 2: CAN-box does not receive the reverse gear signal

If the CAN-bus interface does not receive +12V on the green wire of the 6pin to 8pin cable when reverse gear is engaged (not all vehicles are compatible) an external switching signal from the reverse gear light is required. As the reverse gear light signal contains electronic interference, a traditional open relay (e.g AC-RW-1230 with wiring AC-RS5) or filter (e.g. AC-PNF-RVC) is required. Below schema shows the use of a relay (normally open).

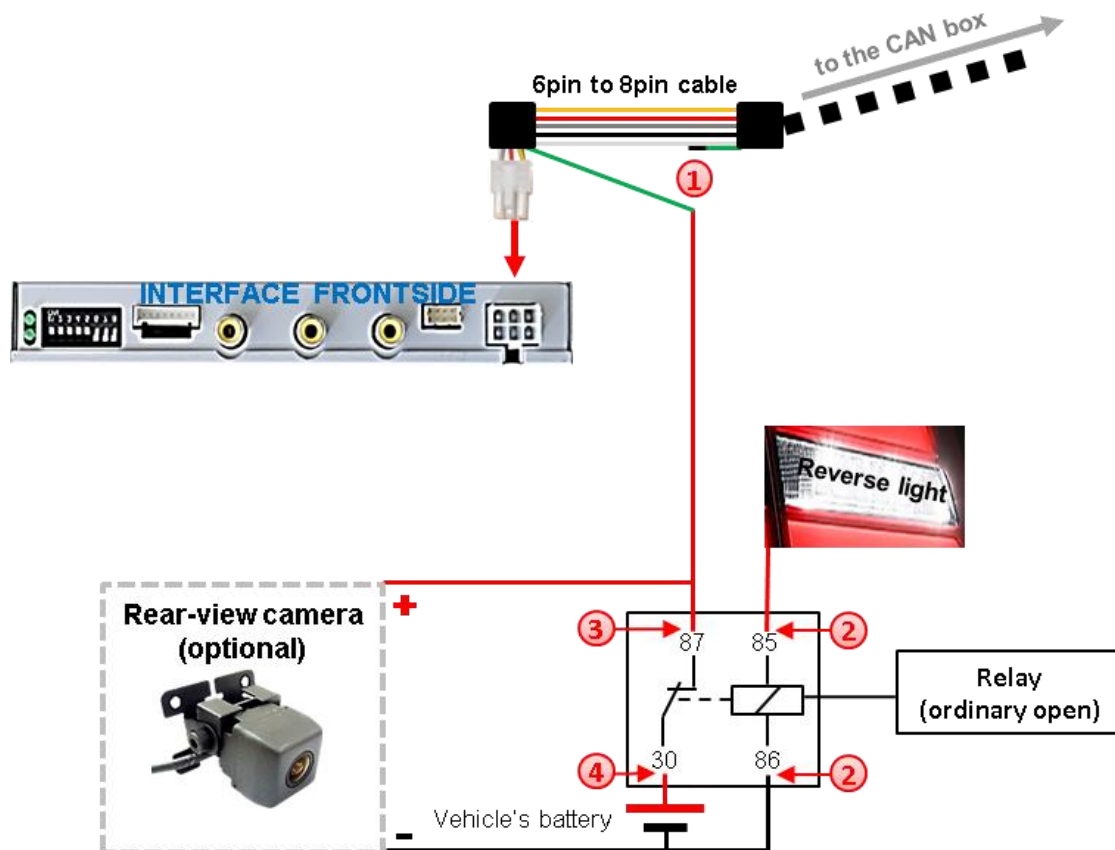

- ① Cut the green cable of the 6pin to 8pin cable close to the black 8pin connector and isolate the shorter end of the green cable near to the 8pin connector (CAN-box side).
- ② Connect the reverse gear light signal/power to coil terminal (85) and vehicle's ground to coil terminal (86) of relay.
- ③ Connect the rear-view camera power wire and the green wire (video interface side) of the 6pin to 8pin cable both to output terminal (87) of the relay.
- ④ Connect permanent battery power to input terminal (30) of relay.

## 2.13. Connecting video-interface - external keypad

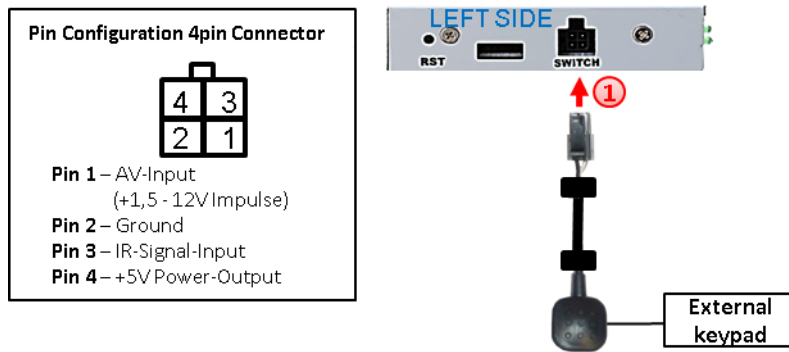

- 1 Connect the keypad's female 4pin connector to the male 4pin connector of the video-interface.

**Note:** Even if the switching through several video sources by the keypad mightn't be required, the keypad's invisible connection and availability is strongly recommended.



## 2.14. Picture settings and guide lines

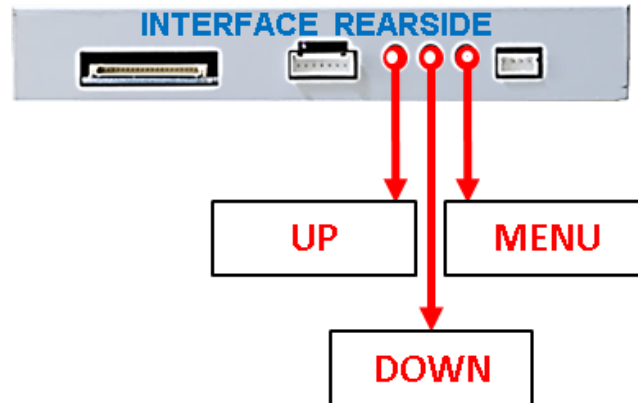

The picture settings are adjustable by the 3 push-buttons on the video-interface. Press the MENU button to open the OSD settings menu or to switch to the next menu item. Press UP and DOWN to change the selected value. The buttons are placed inside in the housing to avoid accidental changes during or after the installation. Picture settings must be done separately for RGB, AV1 and AV2 while the corresponding input is selected and visible on the monitor. **AV2 and CAM share the same settings which must be adjusted in AV2.**

**Note:** The OSD menu is only shown when a working video source is connected to the selected video-input of the interface.

The following settings are available:

- Contrast
- Brightness
- Saturation
- Position H (horizontal)
- Position V (vertical)
- IR-AV1/2 (no function)
- Guide Line

```
Brightness...19
Contrast...50
Saturation...50
Position.H...08
Position.V...05
IR.AV1...NECV0X
IR.AV2...HANTANG
IR.RGB...CHJT
Guide.Line...OFF
```

**Note:** If there is no communication between the CAN box and the vehicle's CAN-bus (several vehicles aren't compatible), the reverse gear guide-lines can't be shown during the vehicle's operation, even if they once appear after having switched the system to powerless!

## 3. Video interface operation

### 3.1. By infotainment button

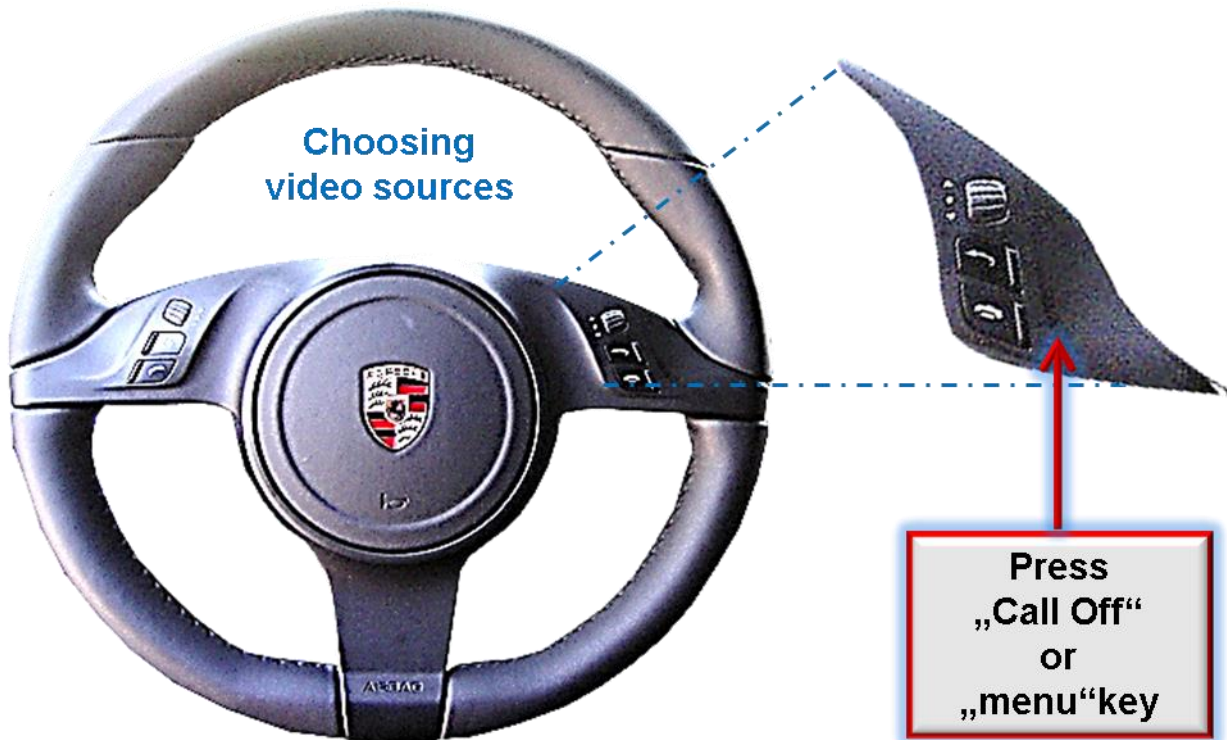

To switch the video sources the vehicle's **Call off button** or **menu button** can be used.

Each press will switch to the next enabled input. If all inputs are enabled the order is:

*Factory video → video IN1 → video IN2 → factory video →...*

Disabled inputs will be skipped. While switching from **Video IN1** to **Video IN2** the audio-source will be switched too, assuming the sources have also been connected to the audio cable.

**Switchover by vehicle buttons isn't possible in all vehicles. In some vehicles the external keypad or the white wire of the 6pin cable has to be used.**

### 3.2. By external keypad or white wire

Alternatively or additionally to the factory-infotainment-buttons the interface's keypad or the white wire of the 6pin cable can be used to switch the enabled inputs. Every +5-12V pulse switches the video interface to the next enabled input.

## 4. Specifications

BATT/ACC range	7V - 25V
Stand-by power drain	8,6mA
Power	160mA
Video input	0.7V - 1V
Video input formats	NTSC
RGB-video amplitude	0.7V with 75 Ohm impedance
Temperature range	-40°C to +85°C
Dimensions video-box	158 x 22 x 93 mm (W x H x D)
Dimensions CAN-box	73 x 22 x 30 mm (W x H x D)

## 5. FAQ – Trouble shooting Interface functions

For any troubles which may occur, check the following table for a solution before requesting support from your vendor.

Symptom	Reason	Possible solution
No picture/black picture (factory picture).	Not all connectors have been reconnected to factory head-unit or monitor after installation.	Connect missing connectors.
	No power on CAN-bus box (all LED CAN-bus box are off).	Check power supply of CAN-bus box. Check CAN-bus connection of CAN-bus box.
	CAN-bus box connected to CAN-bus in wrong place.	Refer to the manual where to connected to the CAN-bus. If not mentioned, try another place to connect to the CAN-bus.
	No power on video-interface (all LED video-interface are off).	Check whether CAN-bus box delivers +12V ACC on red wire output of 8pin to 6pin cable. If not cut wire and supply ACC +12V directly to video-interface.
No picture/black picture/white picture (inserted picture) but factory picture is OK.	No picture from video source.	Check on other monitor whether video source is OK.
	No video-source connected to the selected interface input.	Check settings dips 1 to 3 of video interface which inputs are activated and switch to corresponding input(s).
	LVDS cables plugged in wrong place.	Double-check whether order of LVDS cables is exactly connected according to manual. Plugging into head-unit does not work when the manual says to plug into monitor and vice versa.
Inserted picture totally wrong size or position.	Wrong monitor settings of video-interface.	Try different combinations of dips 7 and 8 of video-interface. Unplug 6pin power after each change.
Inserted picture double or 4 times on monitor.		
Inserted picture distorted, flickering or running vertically.	Video sources output set to AUTO or MULTI which causes a conflict with the interfaces auto detection.	Set video source output fixed to PAL or NTSC. It is best to set all video sources to the same standard.
	If error occurs only after source switching: Connected sources are not set to the same TV standard.	Set all video sources to the same standard.
	Some interfaces can only handle NTSC input.	Check manual whether there is a limitation to NTSC mentioned. If yes, set source fixed to NTSC output.
Inserted picture b/w.	Picture settings have not been adjusted.	Use the 3 buttons and the interface's OSD to adjust the picture settings for the corresponding video input.
Inserted picture qual. bad.		
Inserted picture size slightly wrong.		
Inserted picture position wrong.		
Camera input picture flickers.	Camera is being tested under fluorescent light which shines directly into the camera.	Test camera under natural light outside the garage.
Camera input picture is bluish.	Protection sticker not removed from camera lens.	Remove protection sticker from lens.

Symptom	Reason	Possible solution
Camera input picture black.	Camera power taken directly from reverse gear lamp.	Use relay or electronics to "clean" reverse gear lamp power. Alternatively, if CAN-bus box is compatible with the vehicle, camera power can be taken from green wire of 6pin to 8pin cable.
Camera input picture has distortion.		
Camera input picture settings cannot be adjusted.	Camera input picture settings can only be adjusted in AV2 mode.	Set dip 3 of video-interface to ON (if not input AV2 is not already activated) and connect the camera to AV2. Switch to AV2 and adjust settings. Reconnect camera to camera input and deactivate AV2 if not used for other source.
Graphics of a car in camera input picture.	Function PDC is ON in the interface OSD.	In compatible vehicles, the graphics will display the factory PDC distance. If not working or not wanted, set interface OSD menu item UI-CNTRL to ALLOFF.
Chinese signs in camera input picture	Function RET or ALL is ON (function for Asian market) in the interface OSD.	Set interface OSD menu item UI-CNTRL to ALLOFF or PDCON.
Not possible to switch video sources by OEM button.	CAN-bus interface does not support this function for vehicle.	Use external keypad or cut white wire of 6pin to 8pin cable and apply +12V impulses for AV-switching.
Not possible to switch video sources by external keypad.	Pressed too short.	For video source switching a longer press of about 2.5 seconds is required.
	SW-version of interface does not support external keypad.	Use OEM-button or cut white wire of 6pin to 8pin cable and apply +12V impulses for AV-switching.
Interface does not switch to camera input when reverse gear is engaged.	CAN-bus interface does not support this function for the vehicles.	Cut the green wire of the 6pin to 8pin cable and apply +12V constant from reverse gear-lamp signal. Use relay to "clean" R-gear lamp power.
Interface switches video-sources by itself.	CAN-bus interface compatibility to vehicle is limited.	Cut the grey wire of 6pin to 8pin and isolate both ends. If problem still occurs, additionally cut the white wire of 6pin to 8pin cable and isolate both ends.

## 6. Technical Support

Please note that direct technical support is only available for products purchased directly from NavLinkz GmbH. For products bought from other sources, contact your vendor for technical support.

**NavLinkz GmbH**  
**distribution/tech dealer-support**  
 Heidberghof 2  
 D-47495 Rheinberg

Tel +49 2843 17595 00  
 Email mail@navlinkz.de

 10R-03 5384

Made in China

