

v.LiNK Video-inserter VL3-MIB-STD2



**Compatible with VW vehicles
with Composition Media or Discover Media system
Skoda vehicles with Amundsen or Bolero system
Seat vehicles with Media system plus**

Video-inserter with 2 video + rear-view camera input and CAN control

Product features

- Video-inserter for factory infotainment monitors
- 2 CVBS video-inputs for after-market devices (e.g. DVD-Player, DVB-T tuner)
- CBVS rear-view camera video-input
- Automatic switching to rear-view camera input on engagement of reverse gear
- Activatable parking guide lines for the rear-view camera (not available for all vehicles)
- Video-in-motion in drive mode (ONLY for connected video-sources)
- Video-inputs NTSC compatible

Contents

1. Prior to installation

- 1.1. Delivery contents
- 1.2. Checking the compatibility of vehicle and accessories
- 1.3. Connectors – video interface
- 1.4. Dip switch settings
 - 1.4.1. Settings of the 8 Dip switches (black)
 - 1.4.1.1. Enabling the interface's video inputs (dip 2-3)
 - 1.4.1.2. Rear-view camera setting (dip 5)
 - 1.4.2. Settings of the 4 Dip switches (CAN function – red)

2. Installation

- 2.1. Place of installation
- 2.2. Connection schema
- 2.3. Installation – daughter PCB
 - 2.3.1. Warning notes, concerning the installation of ribbon cables
- 2.4. Connection head-unit – PNP Power / CAN cable
- 2.5. Connection – 12pin interface cable
- 2.6. Connecting the Video sources
 - 2.6.1. After-market rear-view camera
 - 2.6.1.1. Case 1: Video-interface receives the reverse gear signal
 - 2.6.1.2. Case 2: Video interface does not receive the reverse gear signal
- 2.7. Connecting video-interface and external keypad
- 2.8. Picture settings and guide lines

3. Interface operation

- 3.1. By infotainment button
- 3.2. By external keypad

4. Specifications

5. FAQ – Trouble shooting -

6. Technical support

Legal Information

By law, watching moving pictures while driving is prohibited, the driver must not be distracted. We do not accept any liability for material damage or personal injury resulting, directly or indirectly, from installation or operation of this product. Apart from using this product in an unmoved vehicle, it should only be used to display fixed menus or rear-view-camera video when the vehicle is moving (for example the MP3 menu for DVD upgrades).

Changes/updates of the vehicle's software can cause malfunctions of the interface. Up to one year after purchase we offer free software-updates for our interfaces. To receive a free update, the interface has to be sent in at own cost. Wages for de- and reinstallation and other expenditures involved with the software-updates will not be refunded.

1. Prior to installation

Read the manual prior to installation. Technical knowledge is necessary for installation. The place of installation must be free of moisture and away from heat sources.

1.1. Delivery contents

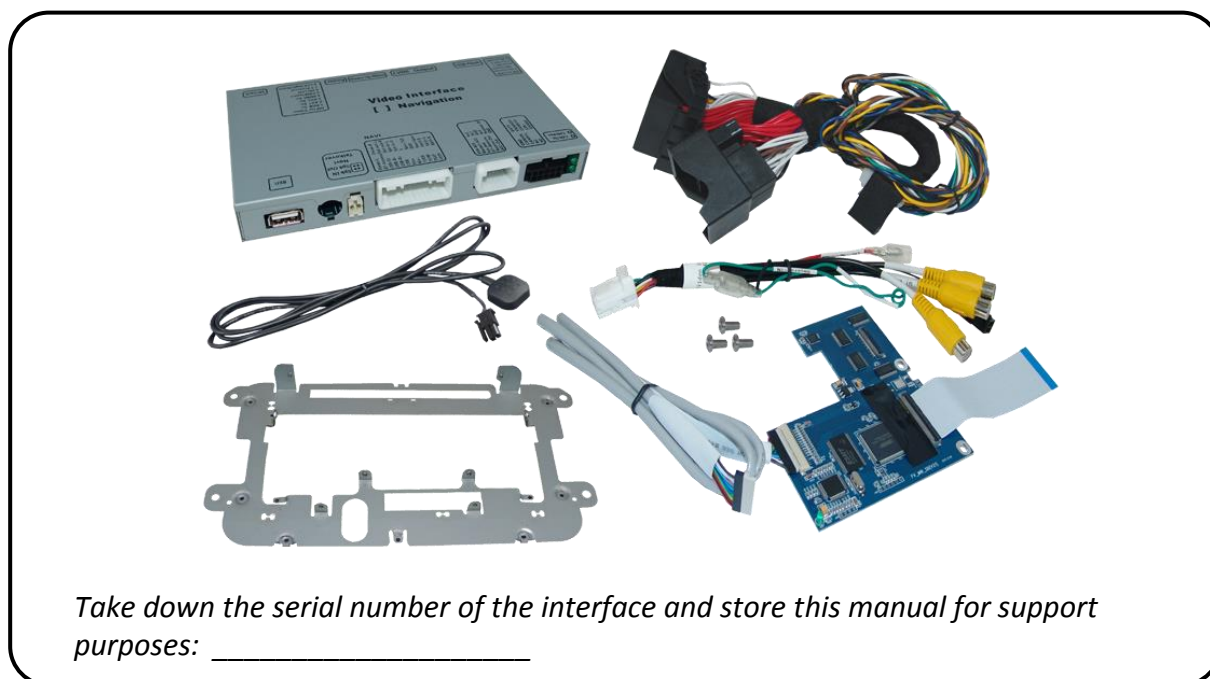

1.2. Checking the compatibility of vehicle and accessories

Compatibility		
vehicle	Compatible vehicles	Infotainment systems
VW	Amarok since model year 2017 Beetle (5C) since model year 2015 Caddy (2K) since model year 2016 Multivan (T6) since model year 2015 Scirocco3 (13) since model year 2016 Sharan (7N) since model year 2016- and other vehicles with 6.33" monitor	MIB STD2 PQ /+NAV Composition Media / Discover Media 1x SD vertical left or 2x SD vertical left + right and disc drive above 6.33inch monitor
Skoda	Yeti (5L) model year 2015-2017	MIB STD2 PQ/+NAV - Amundsen/Bolero 1x SD-Slot vertikall left or 1x SD-Slot vertikall left and right beside the 6.33 Zoll monitor
Seat	Alhambra2 (7N) since model year 2016-	MIB STD2 PQ/+NAV - Media System Plus 1x SD vertical left or 2x SD vertical left + right of 6.33inch monitor

Limitations

Video only The interface inserts ONLY video signals into the infotainment. For sound use the possibly existing factory audio-AUX-input or a FM-modulator.

Connecting 2 AV-sources If 2 AV-sources shall be connected to the infotainment the optional audio switch SW-A2X1 is available, which is controlled by the video interface.

Factory rear-view camera Automatically switching-back from inserted video to factory rear-view camera is only possible while the reverse gear is engaged. To delay the switch-back, an additional electronic part is required.

Vehicles with factory DAB+ Not compatible to vehicles with factory DAB+.

PDC and guidelines If the video interface does not receive the required information from the vehicle CAN-bus, neither guide-lines nor PDC will be supported.

1.3. Connectors - Video-Interface

The video-interface converts the video signals of connected after-market sources in a factory monitor compatible picture signal which is inserted in the factory monitor, by using separate trigger options. Further it reads the vehicle's digital signals out of the vehicle's CAN-bus and converts them for the video interface.

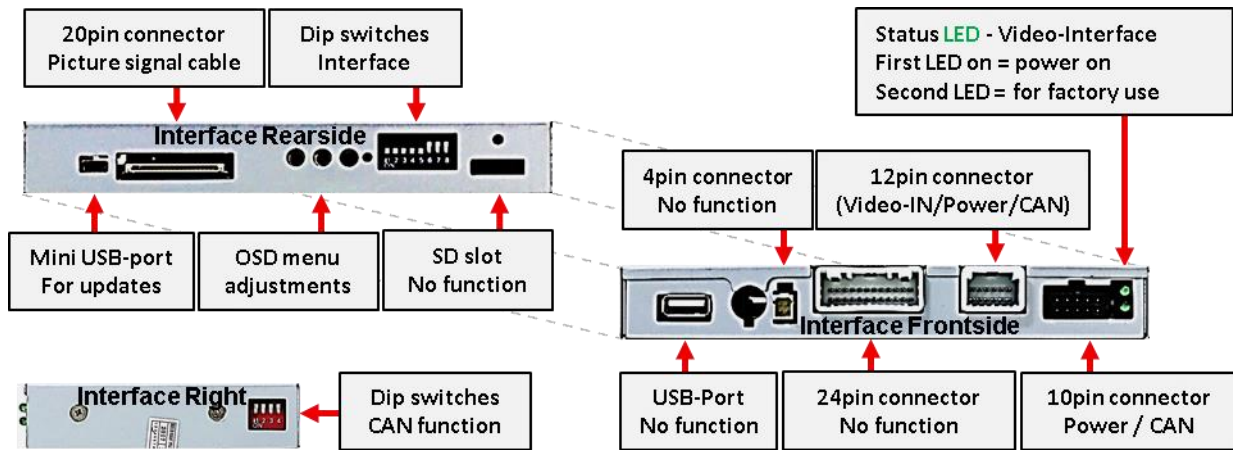

1.4. Dip switch settings

1.4.1. Settings of the 8 Dip switches (black)

Some settings have to be selected by the 8 dip-switches at the video-interface. Dip position down is ON and position up is OFF.



Dip	Function	ON (down)	OFF (up)
1	No function		set to OFF
2	CVBS AV1-input	enabled	disabled
3	CVBS AV2-input	enabled	disabled
4	RGB-input resolution	800x480	1080p H+V sync
5	Rear-view cam type	after-market	factory or none
6	No function	-	set to OFF
7	No function		set to OFF
8	No function		Set to OFF

See the following chapters for detailed information.

After each Dip-switch-change a power-reset of the Can-box has to be performed!

1.4.1.1. Enabling the interface's video inputs (dip 2-3)

Only the enabled video inputs can be accessed when switching through the interface's video sources. It's recommended to enable only the required inputs for the disabled will be skipped when switching through the video-interfaces inputs.

1.4.1.2. Rear-view camera setting (dip 5)

If set to OFF, the interface switches to factory LVDS picture while the reverse gear is engaged to display factory rear-view camera or factory optical park system picture.

If set to ON, the interface switches to its rear-view camera input „Camera-IN“ while the reverse gear is engaged.

Note: Dip 1, 4, 6, 7 and 8 are out of function and have to be set to OFF

1.4.2. Settings of the 4 Dip switches (CAN function - red)

Dip position down is **ON** and position up is **OFF**.

Navigation / SyStem	Dip 1	Dip 2	Dip 3	Dip 4
MIB- STD2 PQ /+NAV	OFF	OFF	OFF	OFF



Dip 1: To switch the AV sources both, by infotainment button (not possible in all vehicles) and external keypad, set this switch to **OFF**. To switch the video sources only by keypad, set to **ON**.

Dip 4: Debug mode for factory. Always set to **OFF**

Dip 2 and Dip3 are out of function. Set to **OFF**

After each Dip-switch-change a power-reset of the Can-box has to be performed!

2. Installation

Switch off the ignition and disconnect the vehicle's battery! The interface needs a permanent 12V source. If -according to factory rules- a disconnection of the battery has to be avoided, it should be sufficient to use the vehicle's sleep-mode. In case, the sleep-mode doesn't succeed, the battery has to be disconnected with a resistor lead.

The Interface needs a permanent power supply! If power isn't directly taken from the battery, the connection's power has to be checked for being start-up proven and permanent.

2.1. Place of installation

The interface is installed on the backside of the head-unit.

2.2. Connection schema

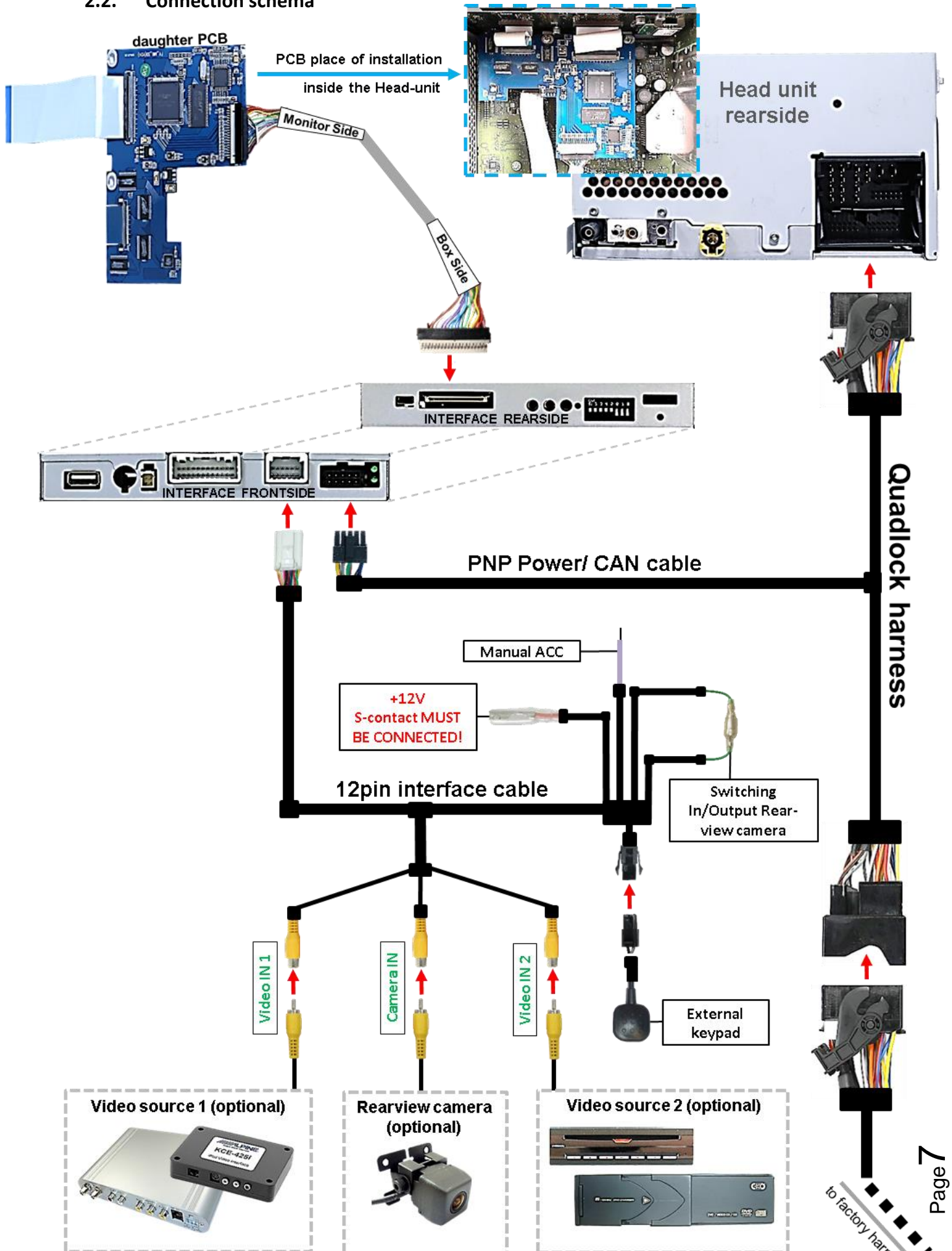

2.3. Installation – daughter PCB

Remove the head-unit and further remove and disconnect the Frontpanel, which is fixed to the head-unit housing by 6 Torx screws (T9).

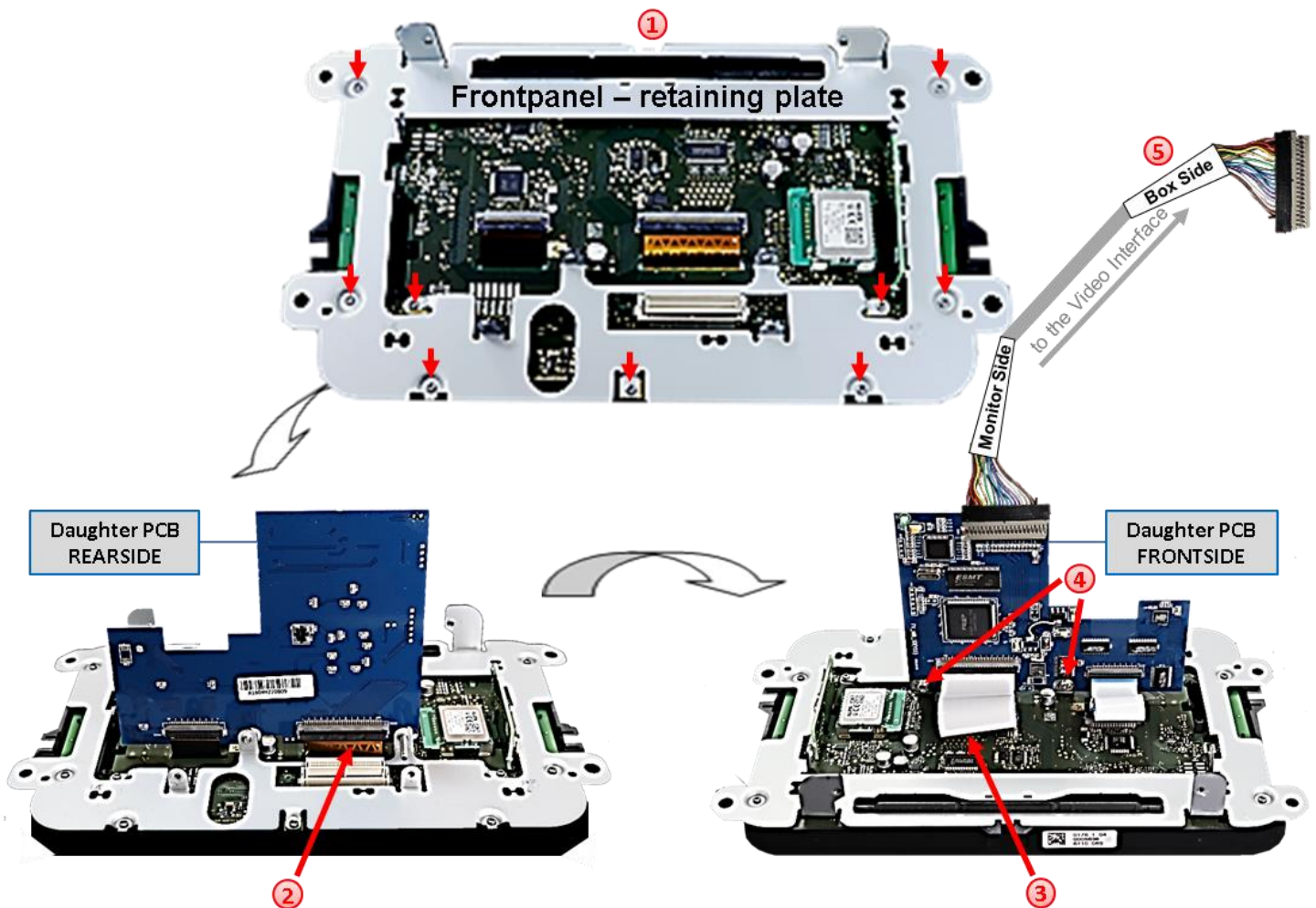

- 1 Replace the original front panel-retaining plate, which is fixed by 9 Torx screws, against the enclosed retaining plate.
- 2 Disconnect the wide golden coloured 60pin ribbon cable at the front panel mainboard 60pin ribbon cable base and connect it to the 60pin ribbon cable base at the daughter PCB's rear side (heed the following warning notes!).
- 3 Connect the daughter PCB's pre-assembled 60pin ribbon cable to the previously become free 60pin ribbon cable base of the mainboard. (heed the following warning notes!).
- 4 After the ribbon cable connection, fix the daughter PCB at the front panel-retaining plate, using the enclosed 2 screws.
- 5 After the daughter PCB's previously mounted 20pin LVDS cable is lead out from the housing at a suitable location, reconnect the front panel with its 6 screws to the head unit's housing. Avoid cable contusion or cable injury caused by sharp-edged metal.

2.3.1. Warning notes, concerning the installation of ribbon cables

1) The contacting ends of ribbon cables always have to be installed in a straight and precise 180° position to the connector. Each deviation from a perfect contact position will cause faulty contact and even danger of short circuit

2) The ribbon cable's contacting side always has to correspond to the contacting side of the connector, concerning the mounting position.

2.4. Connections head-unit – PNP Power / CAN cable

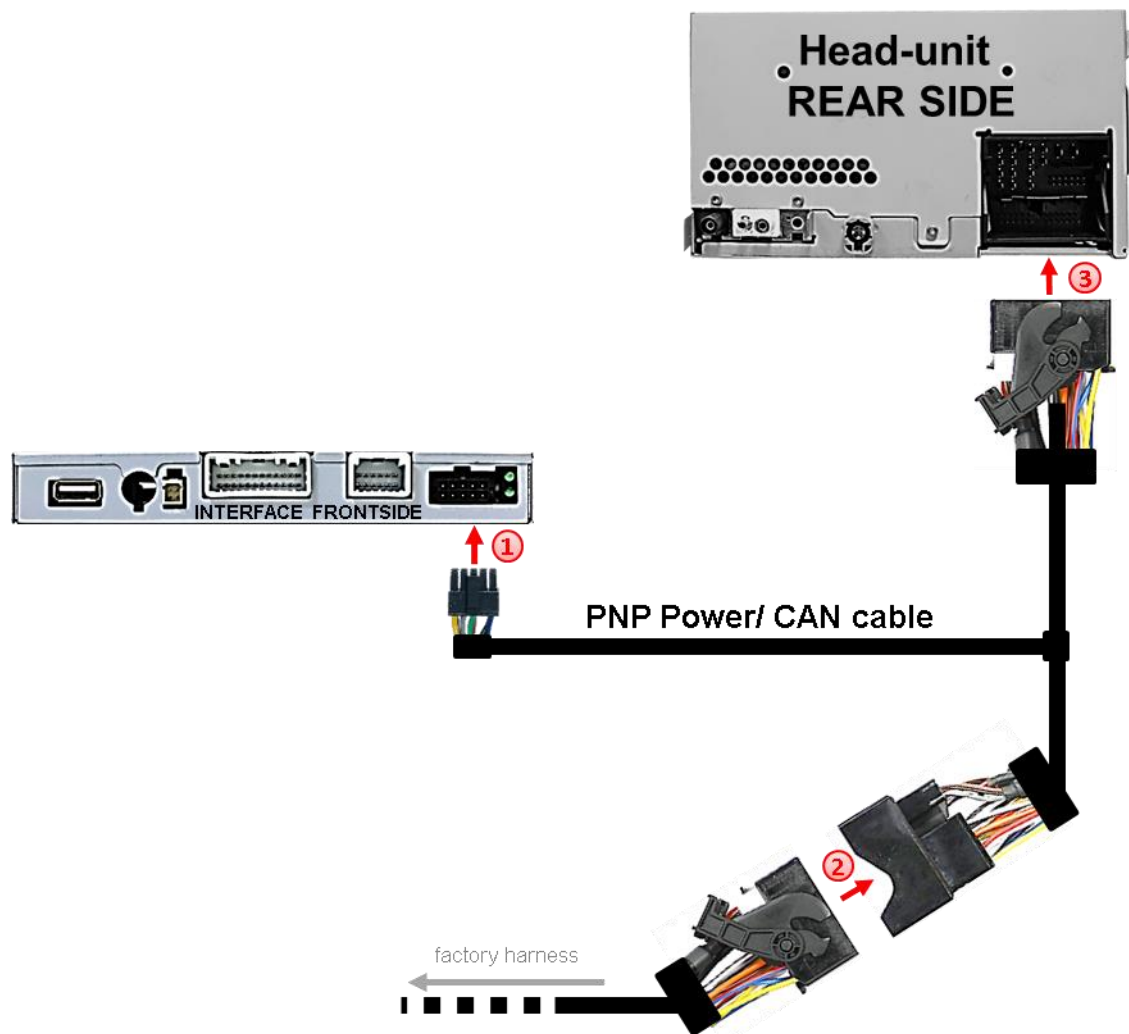

- ① Connect the PNP Power / CAN cable's female 10pin connector to the male 10pin connector of the video-interface.
- ② Disconnect the female Quadlock connector of the factory harness from the head-unit's rear side and connect it to the PNP Power / CAN cable's male Quadlock connector.
- ③ Connect the PNP Power / CAN cable's female Quadlock connector to the male Quadlock connector of the head-unit.

2.5. Connection – 12pin interface cable

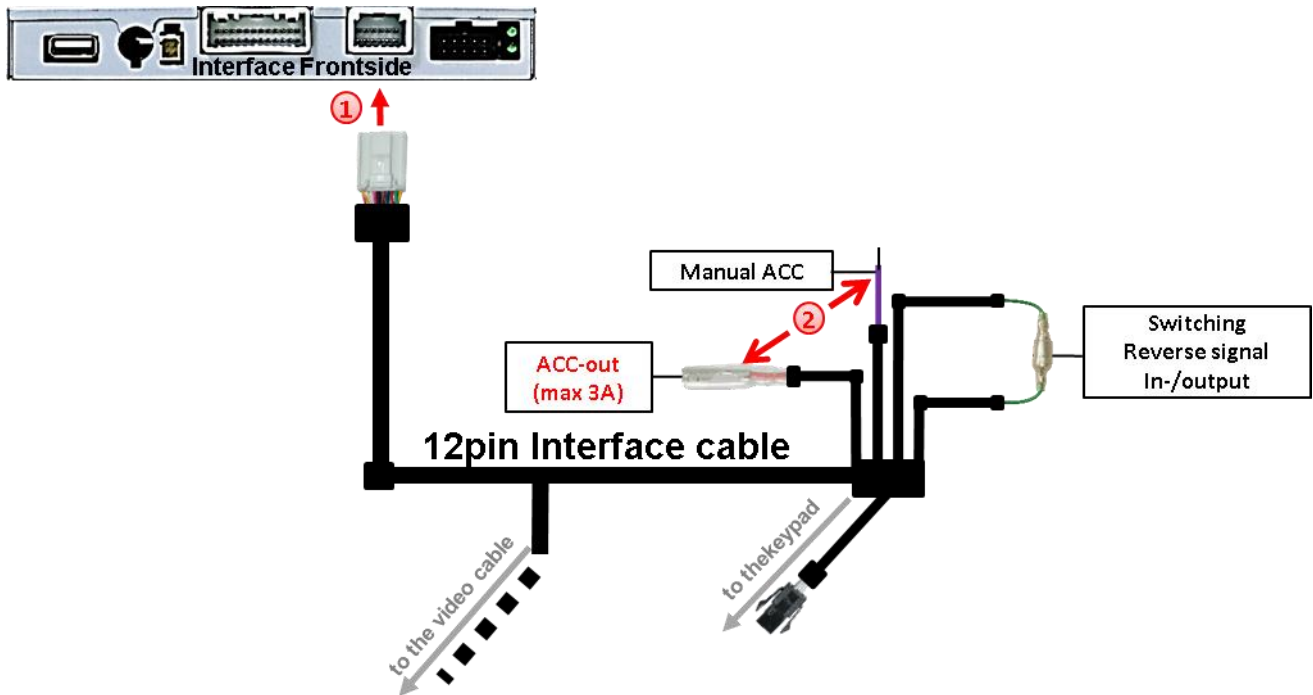

- ① Connect the female 12pin connector of the 12pin interface cable to the male 12pin connector of the video interface.
- ② Connect the 12pin interface cable's red coloured wire **ACC-out (max 3A)** and the purple coloured wire **Manual ACC** both to **+12V S-contact terminal 86s** (e.g. glove compartment illumination).

2.6. Connecting the Video sources

It is possible to connect two after-market AV-sources and one after-market rear-view camera to the video-interface.

Before the final installation, we recommend a test-run to detect a incompatibility of vehicle and interface. Due to changes in the production of the vehicle manufacturer there's always a possibility of incompatibility.

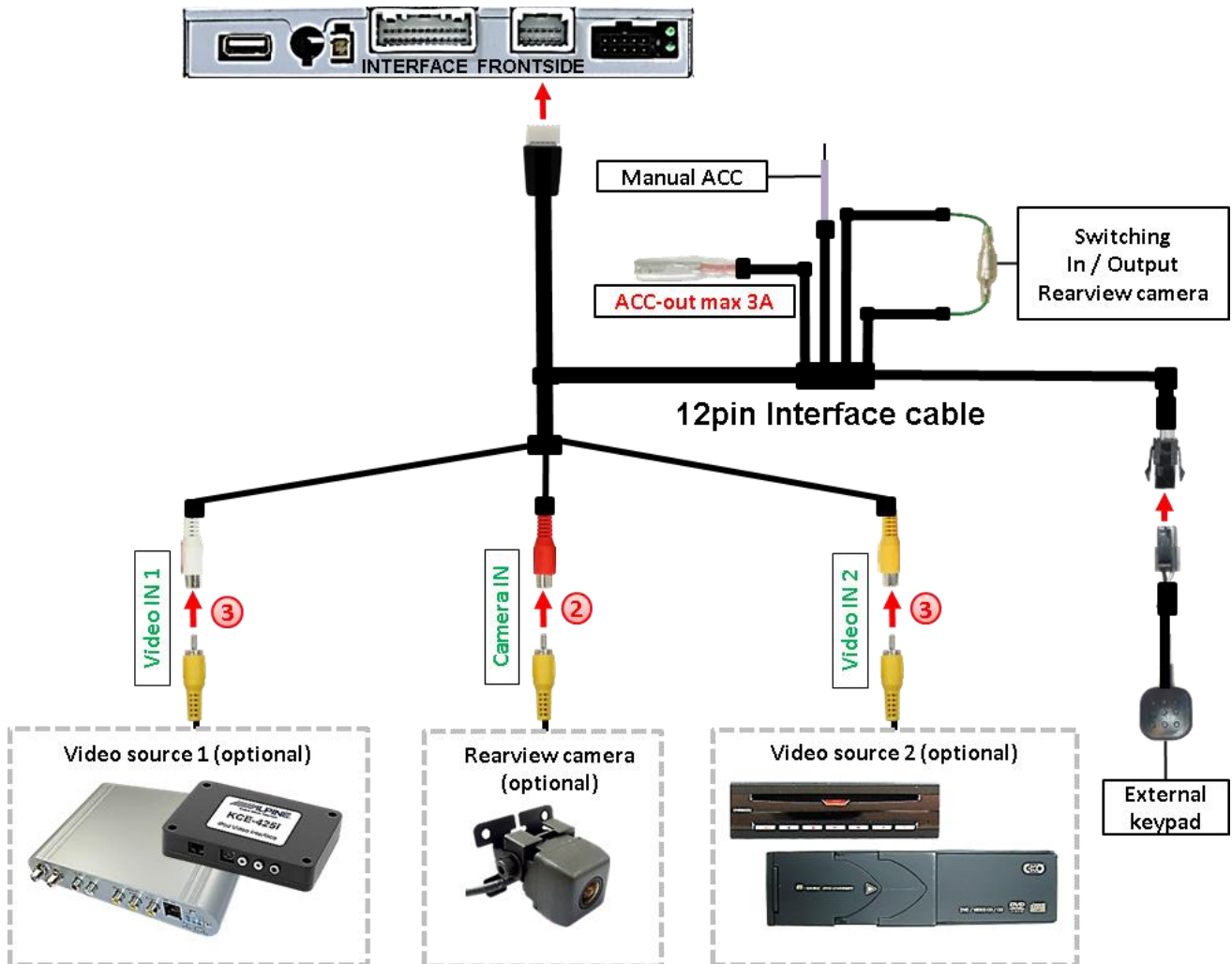

- 1 Connect the female 12pin connector of the 12pin interface cable to male 12pin connector of the video-interface.
- 2 Connect the video RCA connector of the rear-view camera to the female RCA connector **“Camera-IN”** of the 12pin interface cable.
- 3 Connect the video RCA connectors of additional video sources to the 12pin interface cable’s female RCA connectors **„Video IN 1”** and **“Video IN 2”**.

2.6.1. After-market rear-view camera

Some vehicles have a different reverse gear code on the CAN-bus which the video-interface is not compatible with. Therefore, there are two different ways of installation. If the video interface receives a signal of the reverse gear, the green wire “Reverse-OUT” of the 20pin cable should carry +12V while the reverse gear is engaged.

Note: Do not forget to set dip5 of the video-interface to ON before testing.

2.6.1.1. Case 1: Video interface receives the reverse gear signal

If the CAN-bus interface delivers +12V on the green wire of the 20pin cable when reverse gear is engaged, it will automatically be switched to the rear-view camera input CAM while reverse gear is engaged.

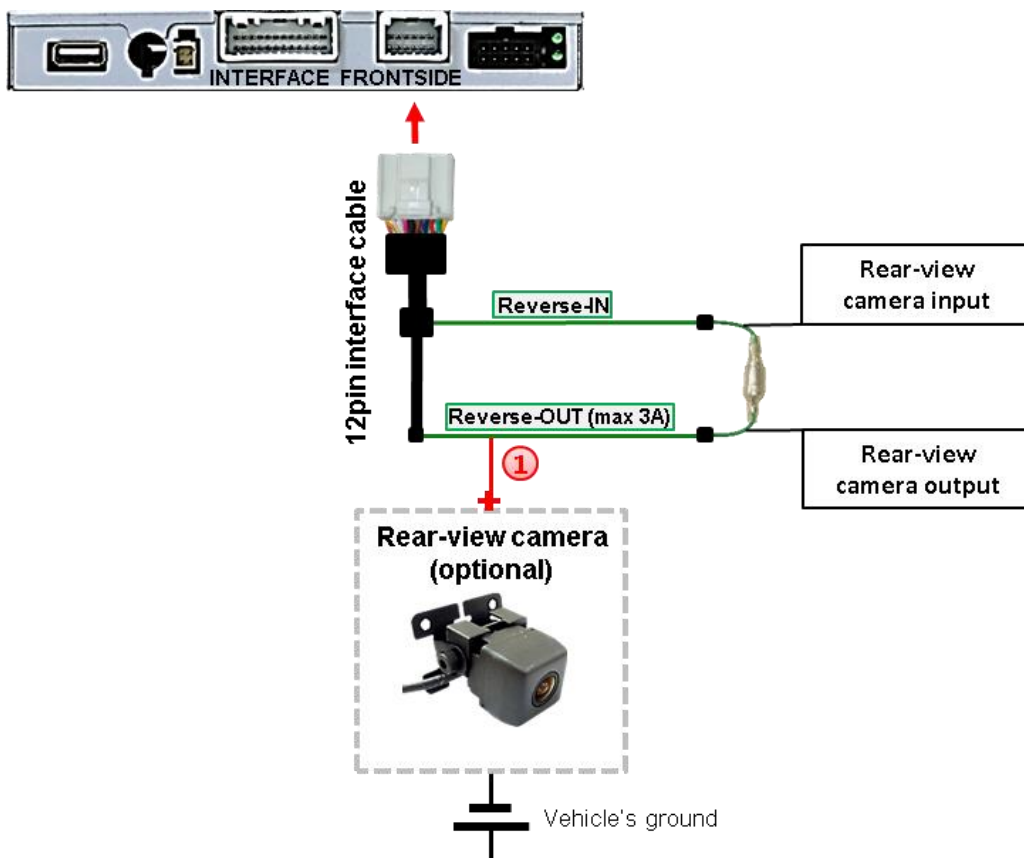

- ① The 12 V power supply for the rear-view camera (max 3A) has to be taken from the green wire “Reverse-OUT” of the 12pin interface cable to avoid an unnecessary, permanent power supply to the camera electronic. Both green cables “Reverse IN” and “Reverse OUT” have to remain connected.

2.6.1.2. Case 2: Video interface does not receive the reverse gear signal

If the video interface does not receive +12V on the green wire of the 12pin interface cable when reverse gear is engaged (not all vehicles are compatible), an external switching signal from the reverse gear light is required. As the reverse gear light's power supply isn't voltage-stable all the time, an ordinary open relay (e.g. AC-RW-1230 with wiring AC-RS5) or filter (e.g. AC-PNF-RVC) is required. The diagram below shows the connection type of the relay.

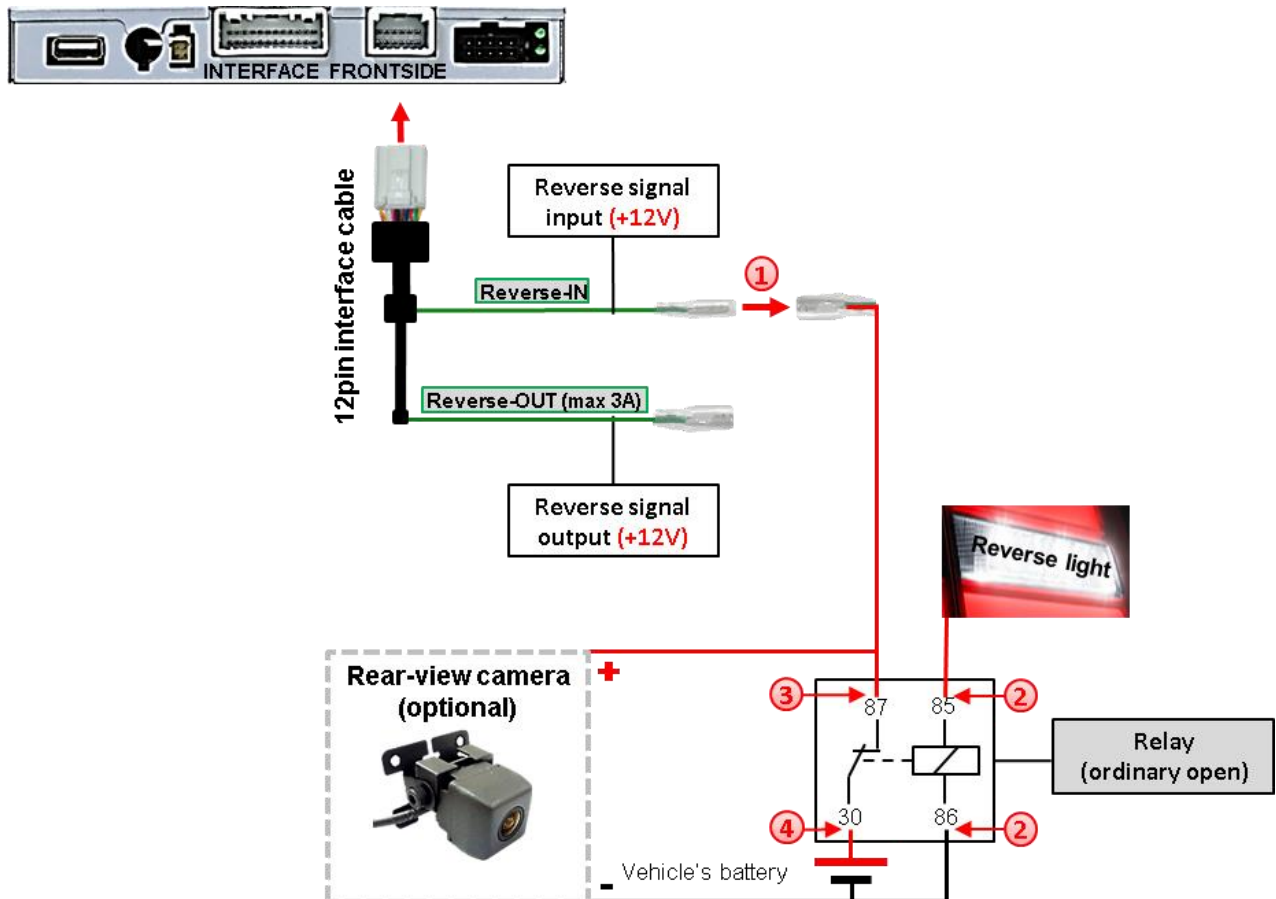

- ① Disconnect the green cable's pre-connected male- and female connectors of the 12pin cable and connect the green input cable "Reverse-IN" to the output connector (87) of the relay.

Note: Not least to avoid short circuits, the best solution should be, to crimp a male 4mm connector to the relay's output cable and connect it to the green cable's female 4mm connector. The output-cable "Reverse-OUT" remains disconnected as it's out of function.

- ② Connect the Reverse light's power-cable to coil (85) and the vehicle's ground to coil (86) of the relay.
- ③ Connect the output connector (87) of the relay to the rear-view camera's power-cable, like you did it to the green "Reverse-IN" cable before.
- ④ Connect permanent power / 12V to the relay's input connector (30).

2.7. Connecting video-interface and external keypad

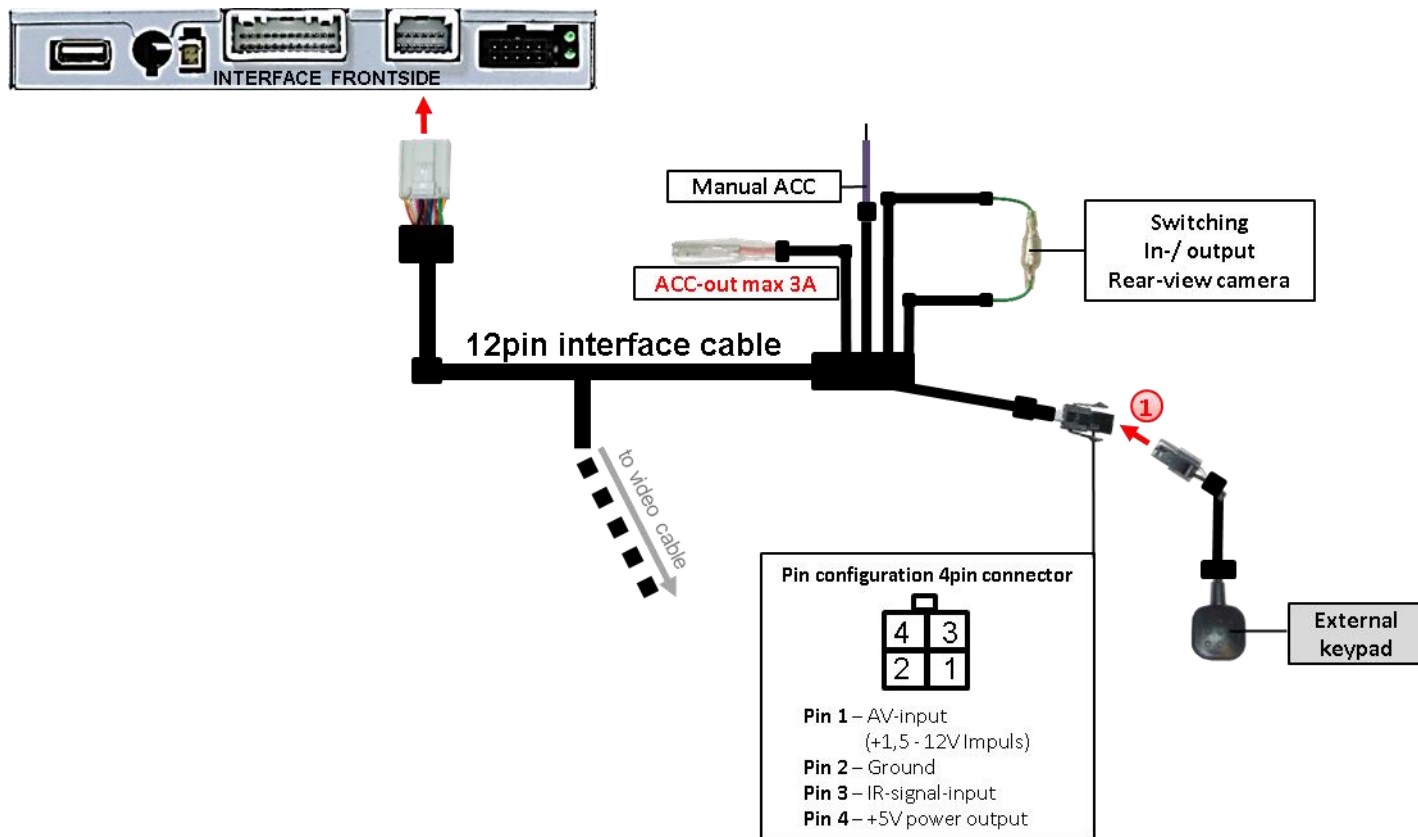

1 Connect the keypad's female 4pin connector to the 12pin interface cable's male 4pin connector.

Note: Even if the switching through several video sources by the keypad mightn't be required, the keypad's invisible connection and availability is strongly recommended.

2.8. Picture settings and guide lines

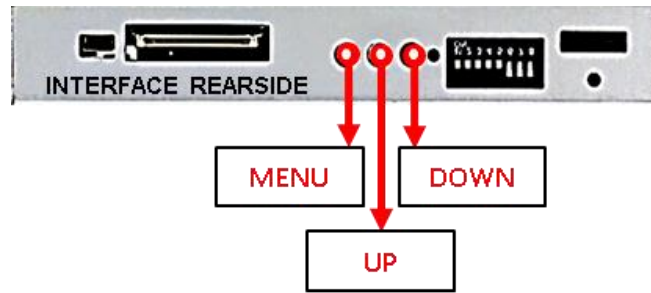

The picture settings are adjusted by the 3 buttons on the video-interface. Press the **MENU** button to open the OSD settings menu. To switch to the next menu item, pressing **UP** and **DOWN** will change the selected value. The buttons are embedded in the housing to avoid accidental changes during or after installation. The picture settings have to be done separately for AV1 and AV2 while the corresponding input is selected and visible on the monitor.

Note: The OSD menu is only shown when a working video source is connected to the selected video-input of the interface.

The following settings are available

- Contrast
- Brightness
- Saturation
- Position H (horizontal)
- Position V (vertical)
- IR-AV1 (out of function)
- IR-AV2 (out of function)
- Guide-lines left
- Guide-lines right
- Guide lines CNTRL (subitems –see red box)

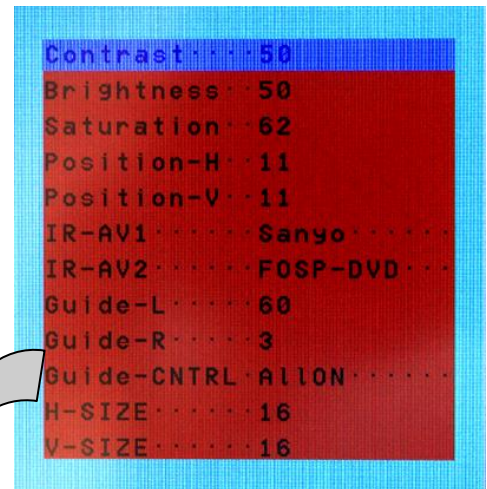

Optionen: GUIDE-CNTRL

- All ON:** Guide lines und PDC werden angezeigt
- PDC ON:** Nur PDC wird angezeigt.
- Guide ON:** Nur Guide lines angezeigt.
- All Off:** Guide lines und PDC werden nicht angezeigt.

Note: If the video interface does not receive the required information from the vehicle CAN-bus, neither moving guide-lines nor PDC will be supported.

3. Interface operation

3.1. By voice key button



A press of the steering wheels voice key switches the input from factory mode to the inserted video sources. If - by dip switch setting - all inputs are enabled, the order is the following:

Factory video → video IN1 → video IN2 → factory video →...

By dip switch deactivated inputs will be skipped. If an audio switch has been connected in the system, also the audio signal will be switched when switching from video IN1 to video IN2

Switchover by vehicle buttons isn't possible in all vehicles. In some vehicles the external keypad has to be used.

3.2. By keypad

Alternatively or additionally to the steering wheel's voice key button, the interface's enabled inputs can also be switched by the external keypad.

4. Specifications

BATT/ACC range	7V - 25V
Stand-by power drain	9,8mA
Power	203mA @12V
Video input	0.7V – 1V
Video input formats	PAL/NTSC
Temperature range	-40°C to +85°C
Dimensions Video-Box	159 x 22 x 94 mm (W x H x D)

5. FAQ – Trouble shooting Interface functions

For any troubles which may occur, check the following table for a solution before requesting support from your vendor.

Symptom	Reason	Possible solution
No picture/black picture (factory picture).	Not all connectors have been reconnected to factory head-unit or monitor after installation.	Connect missing connectors.
	No power on CAN-bus box (all LED CAN-bus box are off).	Check power supply of CAN-bus box. Check CAN-bus connection of CAN-bus box.
	CAN-bus box connected to CAN-bus in wrong place.	Refer to the manual where to connected to the CAN-bus. If not mentioned, try another place to connect to the CAN-bus.
	No power on video-interface (all LED video-interface are off).	Check whether CAN-bus box delivers +12V ACC on red wire output of 8pin to 6pin cable. If not cut wire and supply ACC +12V directly to video-interface.
No picture/black picture/white picture (inserted picture) but factory picture is OK.	No picture from video source.	Check on other monitor whether video source is OK.
	No video-source connected to the selected interface input.	Check settings dips 1 to 3 of video interface which inputs are activated and switch to corresponding input(s).
	LVDS cables plugged in wrong place.	Double-check whether order of LVDS cables is exactly connected according to manual. Plugging into head-unit does not work when the manual says to plug into monitor and vice versa.
Inserted picture totally wrong size or position.	Wrong monitor settings of video-interface.	Try different combinations of dips 7 and 8 of video-interface. Unplug 6pin power after each change.
Inserted picture double or 4 times on monitor.		
Inserted picture distorted, flickering or running vertically.	Video sources output set to AUTO or MULTI which causes a conflict with the interfaces auto detection.	Set video source output fixed to PAL or NTSC. It is best to set all video sources to the same standard.
	If error occurs only after source switching: Connected sources are not set to the same TV standard.	Set all video sources to the same standard.
	Some interfaces can only handle NTSC input.	Check manual whether there is a limitation to NTSC mentioned. If yes, set source fixed to NTSC output.
Inserted picture b/w.	Picture settings have not been adjusted.	Use the 3 buttons and the interface's OSD to adjust the picture settings for the corresponding video input.
Inserted picture qual. bad.		
Inserted picture size slightly wrong.		
Inserted picture position wrong.		
Camera input picture flickers.	Camera is being tested under fluorescent light which shines directly into the camera.	Test camera under natural light outside the garage.
Camera input picture is bluish.	Protection sticker not removed from camera lens.	Remove protection sticker from lens.

Symptom	Reason	Possible solution
Camera input picture black.	Camera power taken directly from reverse gear lamp.	Use relay or electronics to "clean" reverse gear lamp power. Alternatively, if CAN-bus box is compatible with the vehicle, camera power can be taken from green wire of 6pin to 8pin cable.
Camera input picture has distortion.		
Camera input picture settings cannot be adjusted.	Camera input picture settings can only be adjusted in AV2 mode.	Set dip 3 of video-interface to ON (if not input AV2 is not already activated) and connect the camera to AV2. Switch to AV2 and adjust settings. Reconnect camera to camera input and deactivate AV2 if not used for other source.
Graphics of a car in camera input picture.	Function PDC is ON in the interface OSD.	In compatible vehicles, the graphics will display the factory PDC distance. If not working or not wanted, set interface OSD menu item UI-CNTRL to ALLOFF.
Chinese signs in camera input picture	Function RET or ALL is ON (function for Asian market) in the interface OSD.	Set interface OSD menu item UI-CNTRL to ALLOFF or PDCON.
Not possible to switch video sources by OEM button.	CAN-bus interface does not support this function for vehicle.	Use external keypad or cut white wire of 6pin to 8pin cable and apply +12V impulses for AV-switching.
Not possible to switch video sources by external keypad.	Pressed too short.	For video source switching a longer press of about 2.5 seconds is required.
	SW-version of interface does not support external keypad.	Use OEM-button or cut white wire of 6pin to 8pin cable and apply +12V impulses for AV-switching.
Interface does not switch to camera input when reverse gear is engaged.	CAN-bus interface does not support this function for the vehicles.	Cut the green wire of the 6pin to 8pin cable and apply +12V constant from reverse gear-lamp signal. Use relay to "clean" R-gear lamp power.
Interface switches video-sources by itself.	CAN-bus interface compatibility to vehicle is limited.	Cut the grey wire of 6pin to 8pin and isolate both ends. If problem still occurs, additionally cut the white wire of 6pin to 8pin cable and isolate both ends.

6. Technical Support

Please note that direct technical support is only available for products purchased directly from NavLinkz GmbH. For products bought from other sources, contact your vendor for technical support.

NavLinkz GmbH
distribution/tech dealer-support
 Eurotec-Ring 39
 D-47445 Moers

Tel +49 2841 949970
 Email mail@navlinkz.de

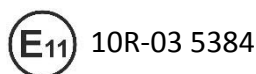

Made in China

