

## Video inserters HDV-MBN6 / RL4-MBN6-A

Compatible with  
**Mercedes Benz** vehicles with  
MBUX/NTG6 with 7inch, 10.25inch or 12inch monitor



examples

**Attention!**  
Video signal type of each video  
source must be preset in OSD-menu  
of corresponding video-input.

### Product features

- 1 x CVBS/AHD-input for rear-view camera
- 1 x CVBS/AHD-input for front camera
- 2 x CVBS/AHD-input for side-cameras or additional after-market video-sources (e.g., USB-device, DVB-T2 Tuner, etc.)
- All inputs NTSC and PAL compatible  
Supported AHD resolutions 720p NTSC (30Hz), 720p PAL (25Hz), 960p NTSC (30Hz), 960p PAL (25Hz), 1080p NTSC (30Hz), 1080p PAL (25Hz)
- **HDV-MBN6 only:** 1 HDMI-input for HD rear-view camera or additional HDMI-sources (e.g., IOS/Android, laptop, streaming stick, DVD-Player, DVB-T2 Tuner, etc.)  
Supported HDMI resolutions 720p NTSC (60Hz), 720p PAL (50Hz), 1080p NTSC (60Hz), 1080p PAL (50Hz)
- Automatic switching to rear-view camera input while reverse gear is engaged
- Automatic front camera switching after reverse gear for 5, 10, 15 or 20 seconds
- Activatable driving-path lines for rear-view camera (not available for all vehicles)
- Picture free during the car ride (only for inserted video-sources)

## Contents

<b>1</b>	<b>Prior to installation</b>	<b>3</b>
1.1	Delivery contents	3
1.2	Checking the compatibility of vehicle and accessories	4
1.3	Limitations	5
1.4	Boxes and connectors - interface	6
1.5	Settings - 8dip switch bench (interface functions)	7
1.5.1	Video inputs V1-Left and V2-Right (dip 1-2)	7
1.5.2	Front camera input V3-Front (dip 3)	7
1.5.3	Rear-view camera settings (dip 4)	8
1.5.4	Rear-view cam connection type (dip 5)	8
1.5.5	HDMI-input* (dip 6)	8
1.5.6	Driving-path lines (dip 7)	8
1.6	Settings - 6dip switch bench (monitor definition)	9
1.7	Settings - 4dip switch bench (CAN-bus)	9
<b>2</b>	<b>Installation</b>	<b>10</b>
2.1	Place of connection	10
2.2	Connection schema	11
2.3	Connection - picture signal cable	13
2.3.1	Picture signal cable - head unit type 1	13
2.3.2	Picture signal cable head unit type 2	14
2.4	Connection – harnesses, power supply and CAN-bus or analogue without CAN-bus	15
2.4.1	Connection with CAN-bus	16
2.4.1.1	Pin connection Power/CAN – all vehicles	17
2.4.1.2	Alternative Pin connection Power/CAN Sprinter W907/910	18
2.4.2	<i>Analogue connection without CAN-bus</i>	19
2.5	Power supply outputs	20
2.5.1	Connection and power-supply - video-sources rear-view camera, front camera and 2 side-cameras	21
2.5.2	Connection and power-supply - video-sources rear-view camera, front camera and 2 video-sources	22
2.6	After-market rear-view camera	23
2.6.1	Case 1: Reverse signal by CAN-bus	23
2.6.2	Case 2: Reverse signal analogue connection	24
2.7	After-market front camera	25
2.8	After-market side-cameras	26
2.8.1	Case 1: Turn signal from CAN-bus	26
2.8.2	Case 2: Turn signal analogue connection	27
2.9	HDMI rear-view camera or other HDMI-source (only HDV-MBN6)	28
2.10	Audio-insertion	29
2.11	Connection - Interface and external keypad	29
2.12	OSD-menu settings	30
<b>3</b>	<b>Interface operation</b>	<b>33</b>
<b>4</b>	<b>Specifications</b>	<b>33</b>
<b>5</b>	<b>FAQ - Troubleshooting interface functions - product-specific</b>	<b>33</b>
<b>6</b>	<b>FAQ - Trouble shooting Interface functions - general</b>	<b>34</b>
<b>7</b>	<b>Technical Support</b>	<b>36</b>

## Legal Information

By law, watching moving pictures while driving is prohibited, the driver must not be distracted. We do not accept any liability for material damage or personal injury resulting, directly or indirectly, from installation or operation of this product. Apart from using this product in an unmoved vehicle, it should only be used to display fixed menus (for example the MP3 menu of USB devices) or (rear-view) cameras' video when the vehicle is moving.

Changes/updates of the vehicle's software can cause malfunctions of the interface. Up to one year after purchase we offer free software-updates for our interfaces. To receive a free update, the interface has to be sent in at own cost. Wages for de- and reinstallation or other expenditures involved with the software-updates will not be refunded.

## 1 Prior to installation

Read the manual prior to installation. Technical knowledge is necessary for installation. The video interface's place of installation must be free of moisture and away from heat sources.

**Before the final installation in the vehicle, we recommend a test-run to ensure the compatibility of vehicle and interface. Due to changes in the production of the vehicle manufacturer there's always a possibility of incompatibility.**

### 1.1 Delivery contents

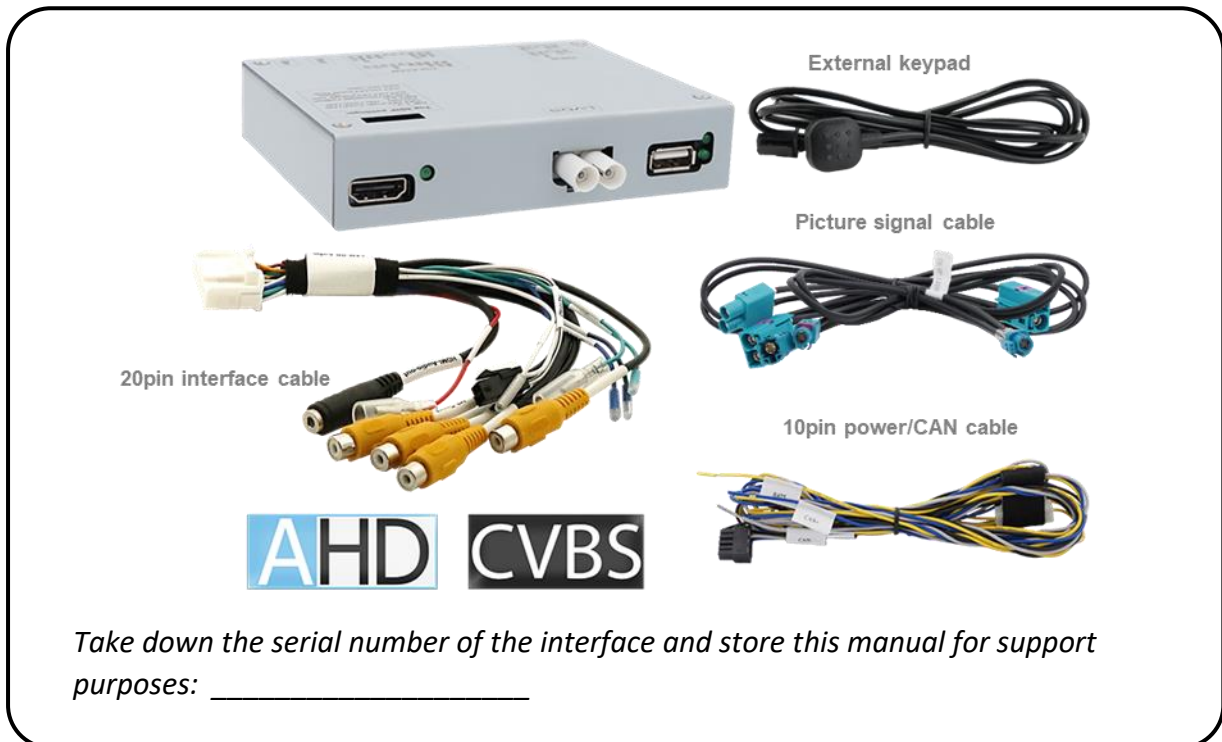

## 1.2 Checking the compatibility of vehicle and accessories

### Requirements

Brand	Compatible vehicles	Infotainments
<b>Mercedes Benz cars</b>	A-class (W177) from 05/2018, B-class (W247) from 12/2018, CLA coupe (C118) from 03/2019, CLA shooting brake (X118) from 07/2019, CLS coupe (C257) from 07/2020-, E-class (W213) from 06/2020 til 08/2023, E-class T-model (S213) from 06/2020 til 08/2023, E-class coupe (C238) from 06/2020 til 10/2023, E-class convertible (A238) from 06/2020 til 10/2023, EQA SUV (H243) from 02/2021, EQB SUV (X243) from 11/2021, EQC (N293) from 05/2019 til 05/2023, EQT (W420) from 05/2023, EQV (W447) from 10/2020, GLA (H247) from 02/2020, GLB (X247) from 09/2019, GLC coupe (C253) about 05/2019 til 03/2023, GLC SUV (X253) about 05/2019 til 07/2022, GLE coupe (C167) from 11/2019, GLE SUV (V167) from 10/2018, GLS (X167) from 04/2019, GT AMG 4door (X290) from 06/2020	<p><b>MBUX Multimedia system with 7, 10.25 or 12 inch touch screen monitor</b></p> <p>MB sales description a.o.: Connect 20 Mid, Connect 20 High</p> <p>MB order codes a.o.: 548, 549</p>
<b>Mercedes Benz trucks/vans</b>	Citan (W420) from 10/2021, Sprinter (W907/W910) from 06/2018, T-class (W420) from 2022, V-class (W447) from 03/2020	<p><b>MBUX Multimedia system with 7 inch touch screen monitor</b> without navigation: MB order code <b>E3M, E6E or E2X</b> with navigation: MB order code <b>E3M+E1E or 6M+E1E</b></p> <p><b>MBUX Multimedia system with 10.25 inch Touch screen monitor</b> with navigation: MB order code <b>E4M</b></p>

## 1.3 Limitations

### Limitations

<i>CAN-bus compatibility</i>	CAN-bus compatibility of interface may to some vehicles have no or limited compatibility. This can show on installation as well as later. Interface and all its video-inputs can be operated with analogue trigger signals, without connection to vehicle CAN-bus. Yet, in this case, some features do not work, see chapter 2.4.2 <i>Analogue connection without CAN-bus</i>
<i>Video only</i>	Interface inserts <b>only video-signals</b> into the infotainment. To insert audio signals a possibly existing factory audio-AUX-input or other optional products (e.g., AUX-UNI0x, FM-Modulator) must be used.
<i>Factory rear-view camera</i>	Automatic switching to factory rear-view camera input is only possible while reverse gear is engaged. For deviating switching times optional accessories are required.
<i>After market front camera</i>	Front camera will automatically be switched to for 5, 10, 15 or 20 seconds (depending on menu setting) after disengaging the reverse gear. Manual switching to front camera is possible by external keypad.
<i>Driving-path lines</i>	It is possible that the vehicle CAN-bus is not fully compatible to the interface or the interface is connected analogue. In these cases, displaying driving-path lines will not be supported.
<i>Factory OBD socket</i>	A permanent connection of an OBD dongle product, e.g. for a tank app or an electronic driver's logbook, may result in partial failure of switching to the rear view camera or side cameras if the switching signal is obtained from the CAN-Bus. In this case an external switching signal from the reverse light and an ordinary open relay or filter are required for the installation of a rear-view camera or side cameras (see chapters: 2.6.2 <i>Case 2: Reverse signal analogue connection</i> and 2.8.2 <i>Case 2: Turn signal analogue connection</i> ).
<i>Vehicles with active Park assistant system 235</i>	While the factory active park assistant system 235 is in use, the displaying of a camera picture is not possible

## 1.4 Boxes and connectors - interface

The interface converts connected after-market sources' video-signals into a video-signal compatible with the factory monitor. It can then be inserted, using separate trigger options. The interface also reads the vehicle's CAN-bus signals and uses them for own functions.

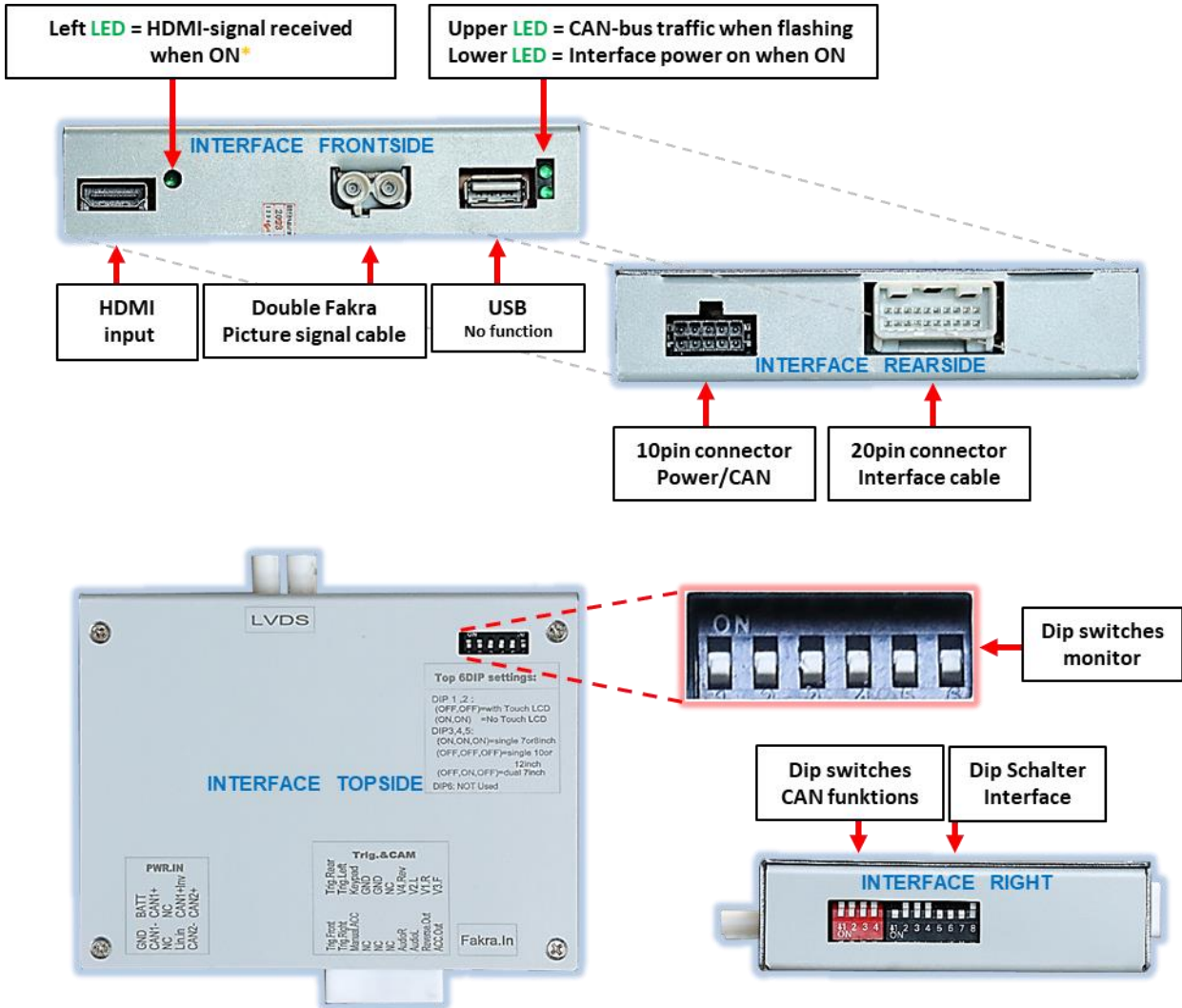

\* HDMI-input only available on HDV-MBN6



## 1.5 Settings - 8dip switch bench (interface functions)

Interface box, right side, black

Dip position **UP = OFF** and **DOWN = ON**.

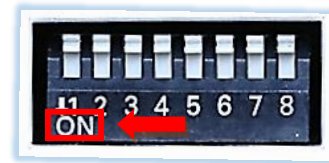

Dip	Function	ON (down)	OFF (up)
1	Video 1 / V1-Left	enabled	disabled
2	Video 2 / V2-Right	enabled	disabled
3	Frontcamera / V3-Front	enabled *	disabled
4	Rear-view cam type (V4-Rear)	after-market	factory or none
5	Connection type of After-market rear-view camera*	HDMI*	V4-Reverse (FBAS/AHD)
6	HDMI-Input*	enabled	disabled
7	Driving-path lines	enabled	disabled
8	No function	enabled	disabled

**Power reset interface after each dip change to activate changes!**

\* The front camera will automatically be switched for 5, 10, 15 or 20 seconds after disengaging reverse gear (depending on OSD-menu setting).

\* On **RL4-MBN6-A**, dip 5 and dip 6 have no function. Set both **OFF**.

See following chapters for detailed information about 8dip switch bench.

### 1.5.1 Video inputs **V1-Left** and **V2-Right** (dip 1-2)

With dip 1 (dip 2) = **ON**, the CVBS/AHD input **V1-Left** (**V2-Right**) for side-camera or other video-sources is enabled. Only enabled video inputs can be accessed – no matter whether automatically or manually switched. We recommend to enable only used inputs to avoid unwanted switching.

### 1.5.2 Front camera input **V3-Front** (dip 3)

With dip 3 = **ON** the interface switches to its CVBS/AHD front camera input **V3-Front** after disengagement of reverse gear. Additionally, manual switching to front camera input is possible by the external keypad (short press) from any video mode.

In the OSD-menu settings it is possible to set the automatic front camera display time from 5, 10; 15 or 20 seconds or shut it off. Therefore, it is also possible to connect a video-source other than from camera.

## 1.5.3 Rear-view camera settings (dip 4)

With dip 4 = **OFF**, the interface switches to factory picture while reverse gear is engaged, to display factory rear-view camera or factory optical park system picture.

With dip 4 = **ON**, while the reverse gear is engaged the interface switches to its CVBS/AHD rear-view camera input **V4-Reverse** (provided that dip 5 is set to **OFF**) or to its **HDMI-input\*** (provided dip 5 and dip 6 are set to **ON**).

**Note:** **V4-Reverse** remains without function with HDMI rear-view camera (dip 5 = **ON**).

## 1.5.4 Rear-view cam connection type (dip 5)

With dip 5 = **ON**, the **HDMI-input\*** will be used as rear-view camera input. Additionally, the **HDMI-input\*** must be enabled with dip 6 = **ON**.

With dip 5 = **OFF**, the **V4-Reverse** input is used as rear-view camera input.

**Note:** Automatic switching to front camera for the pre-set time, after disengaging reverse, is working in both cases.

## 1.5.5 HDMI-input\* (dip 6)

With dip 6 = **ON**, the **HDMI-input\*** is enabled and can be used for various HDMI-sources (e.g., rear-view camera or 360° camera-system, smartphone, laptop, streaming stick, DVB-T2 tuner, etc.). For rear-view camera or 360° camera system, additionally set dip 5 = **ON**.

With dip 6 = **OFF**, the **HDMI-input\*** is disabled.

## 1.5.6 Driving-path lines (dip 7)

With dip 7 = **ON**, the driving-path lines are enabled and shown on the display.

With dip 7 = **OFF**, the driving-path lines are disabled and not shown on the display.

**Note:** On vehicles, where driving-path lines due to lack of CAN-bus compatibility are not shown or are subject to post installation problems, the function cannot be used. In this case set dip 7 = **OFF**.

\* **HDMI-input only available on HDV-MBN6**

**Power reset interface after each dip change to activate changes!**



## 1.6 Settings - 6dip switch bench (monitor definition)

Interface box, top side, black

**Attention!**  
Flip the dip switch very carefully with a micro tool.



**Attention:** Opposite to other dip benches (8dip and 4dip), the 6dip position here is **UP = ON** and **DOWN = OFF!**

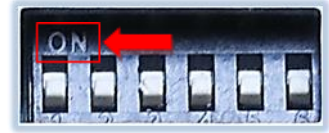

Monitor size	Dip 1	Dip 2	Dip 3	Dip 4	Dip 5	Dip 6
<b>7inch monitor</b> Sprinter (W907/910) GLC (X253)	OFF	OFF	ON	ON	ON	OFF
<b>7"inch monitor</b> A-Class (W177)* B- Class (W247)* CLA Coupé (C118)* CLA Shooting B (X118)* GLA (H247)* GLB (X247)*	OFF	OFF	OFF	ON	OFF	OFF
<b>10.25 inch monitor</b> Sprinter (W907/910) A- Class (W177) B- Class (W247) CLA Coupé (C118) CLA Shooting B (X118) EQC (N293) GLA (H247) GLB (X247) GLC (X253) GLE Coupé (C167) GLE SUV (W167) GLS- Class (X166)	OFF	OFF	OFF	OFF	OFF	OFF

Complete list of vehicle model and year – see page 4

**If picture- or touch problems appear, try also the other dipswitch settings!**

**Power reset interface after each dip change to activate changes!**

## 1.7 Settings - 4dip switch bench (CAN-bus)

Interface box, right side, red

Set dips according to below table.

Dip position **UP = OFF** and **DOWN = ON.**

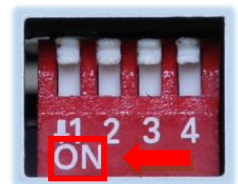

Vehicle/Navigation	Dip 1	Dip 2	Dip 3	Dip 4
All vehicles	OFF	OFF	OFF	OFF
Vehicles with factory active park assistant system 235	ON	OFF	OFF	OFF

**Note:** During the use of the factory active park assistant system 235, no camera image is available.

**Power reset interface after each dip change to activate changes!**

## 2 Installation

**For installation, first switch off the ignition and disconnect the vehicle's battery following the instructions of the vehicle manufacturer regarding battery disconnection! If disconnecting battery is not suggested, enable vehicle sleep-mode (hibernation mode).**

**In case the sleep-mode does not succeed, the disconnection of battery can be done with a resistor lead.**

**Before final installation, a test-run of interface and all connected devices is recommended to ensure compatibility of the complete installation. Due to at any time possible changes in the vehicle manufacturers' productions, incompatibilities can never be ruled out.**

**As on any installation of retrofit equipment, a stand-by test is necessary after installation to ensure that the retrofit products switch off after the vehicle enters sleep mode.**

### 2.1 Place of connection

Depending on the vehicle model, the place of connection of the MBUX head unit to which the connection is made, varies.

#### Examples:

- A-Class (W177), B-Class W247), GLA (H247):  
on the A-pillar on the driver's side
- GLE (W167 und C167):  
under the passenger seat
- Sprinter (W907/910):  
behind the factory monitor
- Citan/T-Klasse W420:  
behind the glove compartment

# Manual

## 2.2 Connection schema

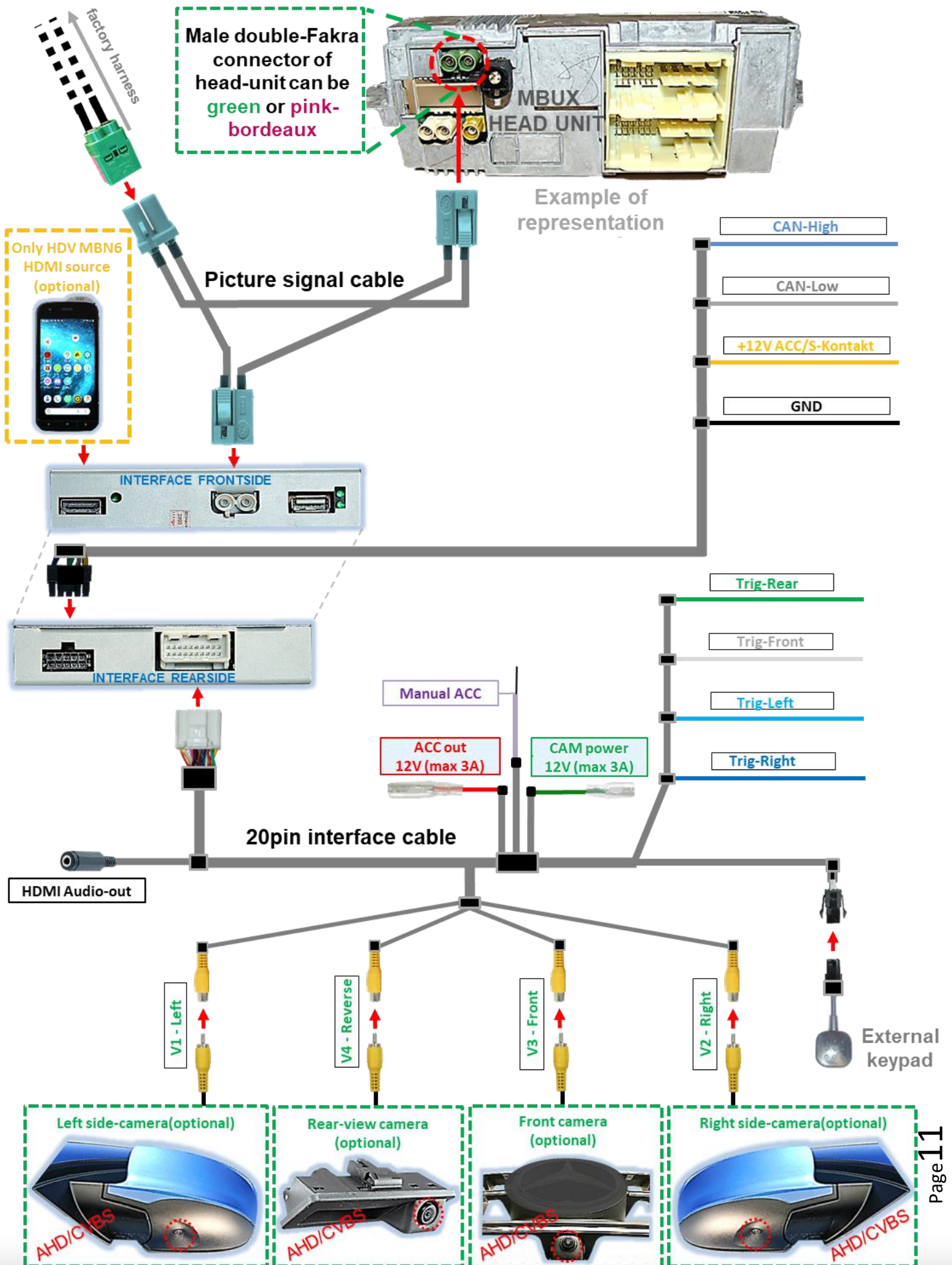

## Attention:

Depending on the vehicle, two different head units were installed.  
The connection differs between HU **type 1** and HU **type 2**.

### Head Unit **type 1**

**Pink/bordeaux coloured Double Fakra**

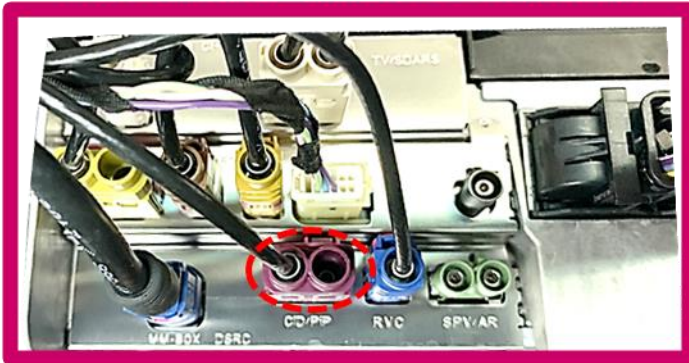

### Head Unit **type 2**

**Green Double Fakra** (pink/bordeaux doesn't exist)

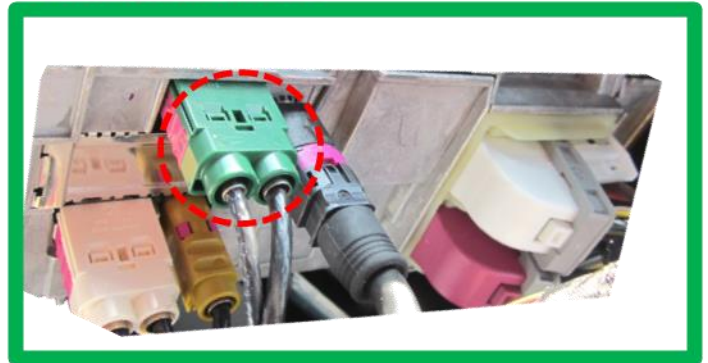

### 2.3 Connection - picture signal cable

#### 2.3.1 Picture signal cable - head unit type 1

If a pink/bordeaux Double Fakra is present at the head unit's rear-side, the picture signal cable has always to be connected to the pink/bordeaux one.

Remove the head unit and disconnect the rearside's pink-bordeaux coloured female double Fakra connector.

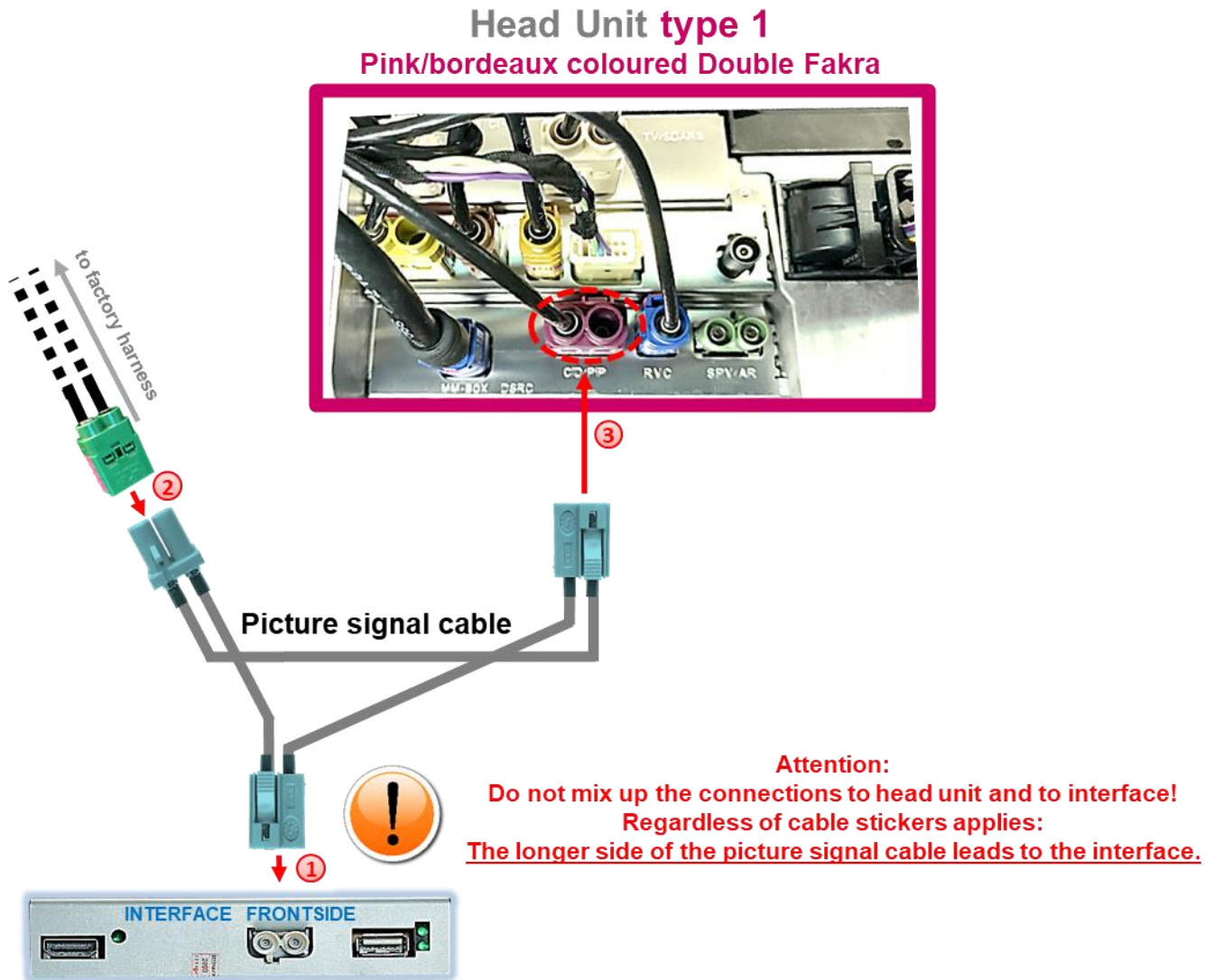

- ① Connect the picture signal cable's waterblue coloured female Double Fakra connector to the male double Fakra connector of the video interface.
- ② Disconnect the female double Fakra connector at the head unit's male pink-bordeaux coloured Double Fakra connector and connect it to the male waterblue coloured double Fakra connector of the enclosed picture signal cable.
- ③ Connect the picture signal cable's waterblue coloured female Double-Fakra connector to the head unit's pink-bordeaux coloured Double-Fakra connector.



Attention: The picture signal cable's connection has always to be done at the head unit's Double Fakra, even if only one side of the factory Double Fakra is occupied!



### 2.3.2 Picture signal cable head unit type 2

If **no** pink/bordeaux Double Fakra is present at the head unit's rear-side, the picture signal cable has to be connected to the green one.

Remove the head unit and disconnect the rearside's **green** female double Fakra connector.

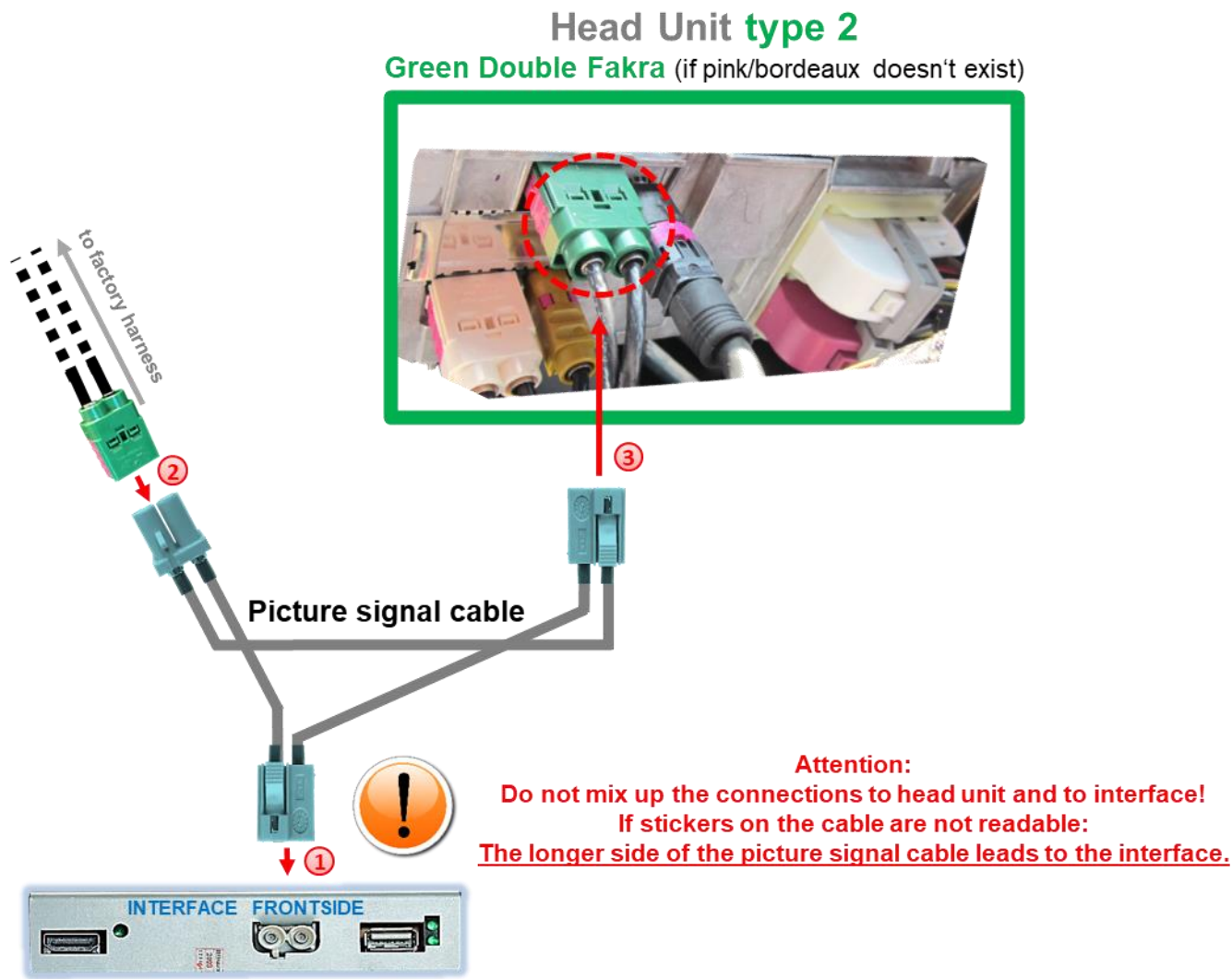

- 1 Connect the picture signal cable's waterblue coloured female Double Fakra connector to the male double Fakra connector of the video interface.
- 2 Disconnect the female double Fakra connector at the head unit's male **green** coloured Double Fakra connector and connect it to the male waterblue coloured double Fakra connector of the enclosed picture signal cable.
- 3 Connect the picture signal cable's waterblue coloured female Double-Fakra connector to the head-unit's **green** coloured Double-Fakra connector.



## 2.4 Connection – harnesses, power supply and CAN-bus or analogue without CAN-bus

The interface can be integrated via CAN-bus as well as operated in analogue mode without CAN-bus connection.

When integrated via CAN-bus, the interface is switched on by the vehicle CAN-bus and R-gear signal and turn signals are usually recognized. In some vehicles also driving-path lines can be displayed, using CAN-bus steering signals and parking sensor data.

Exceptionally, the CAN-communication is not (fully) compatible. If after connection of **10pin power/CAN cable** with ignition on, no interface LED is on, the analogue connection described hereinafter must be made. Also, to avoid possible afterwards CAN-bus incompatibility, an analogue connection is also possible. Thereby the interface must be switched on as well as switched over to its inputs by +12V switch inputs.

**With analogue connection, driving-path lines cannot be displayed.**

No matter whether connection is done with CAN-bus or analogue without CAN-bus, **black GND wire** and **yellow +12V ACC/S-contact wire** of 10pin power/CAN cable must be connected.

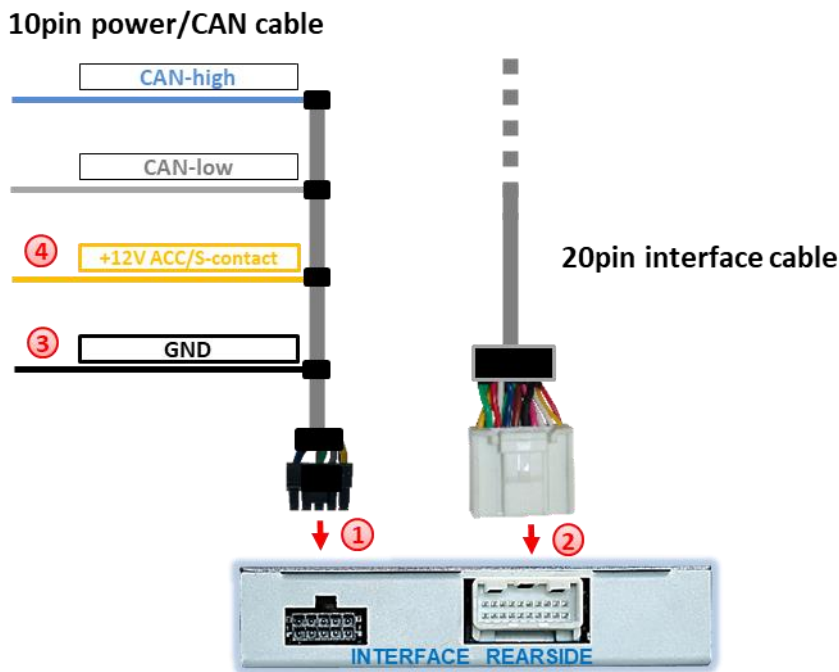

- ① Connect female 10pin connector of 10pin power/CAN cable to male 10pin connector of interface.
- ② Connect female 20pin connector of 20pin interface cable to male 20pin connector of interface.
- ③ Connect **black GND wire** of 10pin power/CAN cable to stable vehicle's negative ground.
- ④ Connect **yellow +12V ACC/S-contact wire** of 10pin power/CAN cable to **+12V ACC (terminal 15r) or S-contact (terminal 86s)** of vehicle.

## 2.4.1 Connection with CAN-bus

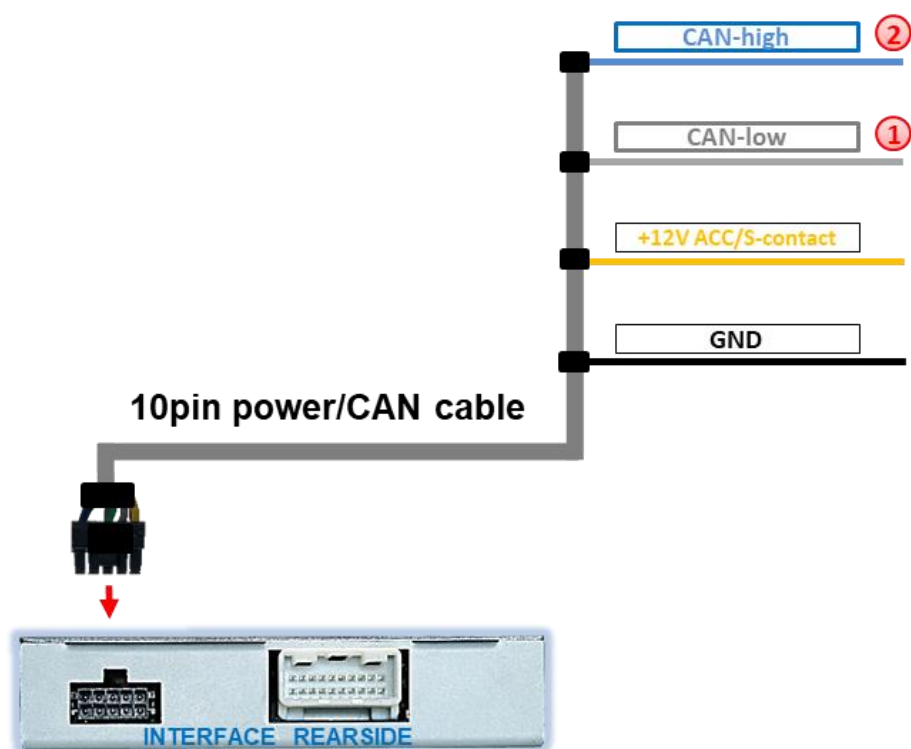

- 1 Connect grey wire of 10pin power/CAN cable to vehicle's CAN-low (see following chapters for place of connection).
- 2 Connect blue wire of 10pin power/CAN cable to vehicle's CAN-high. (see following chapters for place of connection).

**Attention!**  
If connecting to CAN-bus in combination with yellow wire to +12V BATT (terminal 30), it could happen generally or sporadically that the interface does not shut off in sleep mode. Therefore, connecting the yellow wire to +12V BATT is at own risk.

### 2.4.1.1 Pin connection Power/CAN – all vehicles



**Attention:** The two CAN wires may only be connected at the following specified points. Tapping the CAN information at other points can cause malfunctions.

#### Head Unit **Type 1** with **pink-bordeaux** Double-Fakra



Pin-assignment RL4 10pin Power/CAN	Pin-Belegung <b>Type 1</b> black 26pin locking connector
● CAN High blue	● Pin 7 purple white **
● CAN Low grey	● Pin 20 purple **
● +12V battery yellow	● Pin 14 red
● Ground black	● Pin 1 brown

Alternatively, the plug&play connection can be made with article **PNP-MBUX31P**.

#### Head Unit **Type 2** with **green** Double-Fakra



Pin-assignment RL4 10pin Power/CAN	Pin-assignment <b>Type 2</b> white 31pin connector
● CAN High blue	● Pin 15 purple white **
● CAN Low grey	● Pin 22 purple **
● +12V battery yellow	● Pin 1 red
● Ground black	● Pin 6 brown

Alternatively, the plug&play connection can be made with article **PNP-MBUX31P**.

**\*\*** CAN bus colours on the vehicle can also be **yellow/white** and **yellow!**

### 2.4.1.2 Alternative Pin connection Power/CAN Sprinter W907/910

As an alternative connection option, **if an RVC preinstallation (code FR7) exists,** Power and CAN can also be tapped at the 4-pin socket with the same cable colours under the driver's seat for both HU types.



**Note:** The factory FR7 RVC preparation is only present:

**for Type 1** – when the blue single fakra on the head-unit is connected

**for Type 2** – when the green double fakra is twice-connected on the head unit.

Pin-assignment RL4 10pin Power/CAN	Head-units with FR7 RVC pre-fitting <b>Type 1</b> und <b>Type 2</b>
● CAN High blue	● purple white
● CAN Low grey	● purple
● +12V battery yellow	● red
● Ground black	● brown

**There's no liability for the vehicle's pin diagram! Changes in the manufacturer's production are possible any time. The mentioned information has to be verified by the installer.**

## 2.4.2 Analogue connection without CAN-bus

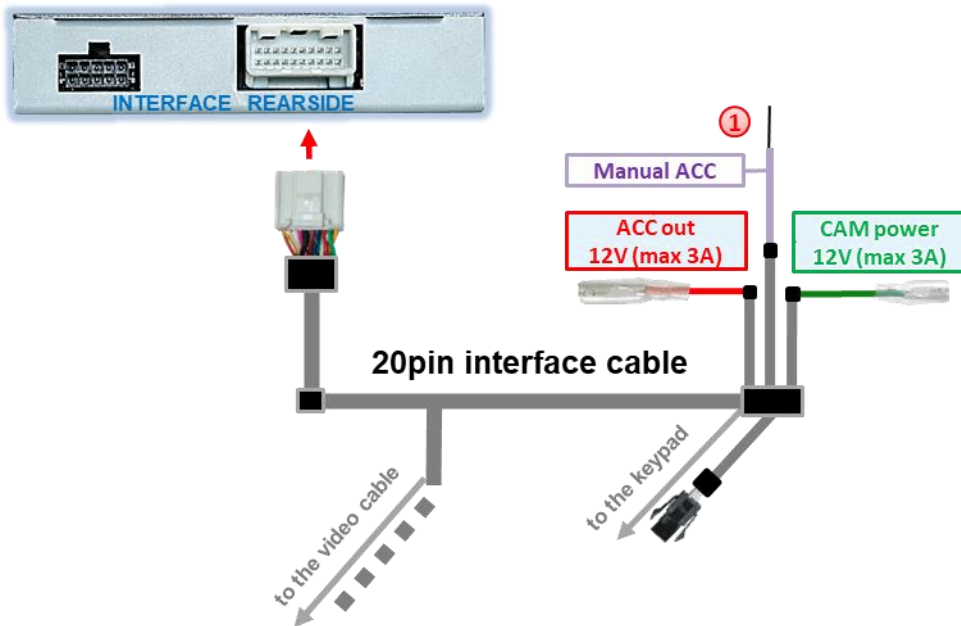

- 1 Connect **purple wire Manual ACC** of 20pin interface cable to **+12V S-contact terminal 86s or ACC terminal 15r** of vehicle (e.g., cigarette lighter, glove compartment illumination).

### Notes



- Only as long as the interface is switched on via +12V on **Manual ACC**, the monitor can show picture. Otherwise, also the factory picture is black. When selecting the switch-on signal, please check whether the factory picture is available in all desired operating states.
- With analogue connection, driving-path lines cannot be displayed.
- With analogue connection of interface (without CAN-bus), the connection of rear-view camera and side-cameras must also be made analogue. See chapters:  
*2.6.2 Case 2: Reverse signal analogue connection*  
*2.8.2 Case 2: Turn signal analogue connection*

## 2.5 Power supply outputs

The two **red** and **green** power supply cables **ACC out 12V (max 3A)** and **CAM power 12V (max 3A)** of the **20-pin interface cable** can be used either as ACC power supply for **external video-sources** connected to the inputs **V1-Left, V2-Right, V3-Front** or **HDMI-input\*** (e.g., iOS/Android devices, laptop, streaming stick, DVB-T2 tuner), or as power supply for the **after-market cameras** connected to the **V1-Left, V2-Right, V3-Front, V4-Reverse** or **HDMI-input\*** (e.g., rear-view, front and side-cameras).

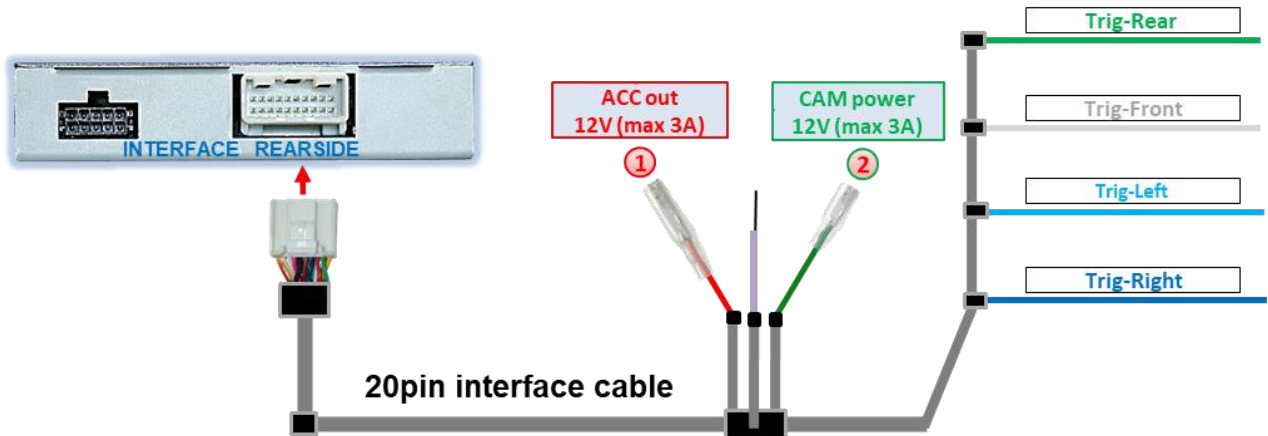

- 1** **External video-sources** (no cameras) can be supplied with power via the red power supply cable **ACC out 12V (max 3A)** of the **20pin interface cable**. The cable carries +12V ACC trigger out power **permanently** while interface is powered (*see following chapters for connection*).
- 2** The power supply for **after-market cameras** (e.g., rear-view, side and/or front camera) can be supplied by the green power supply cable **CAM power 12V (max 3A)** of the **20pin interface cable**. The cable carries **+12V trigger out power** exclusively as long as any of the camera inputs is shown, regardless of whether the switching is by vehicle CAN-bus or by trigger wires (*see following chapters for connection*).

\* **HDMI-input only available on HDV-MBN6**



### 2.5.1 Connection and power-supply - video-sources rear-view camera, front camera and 2 side-cameras

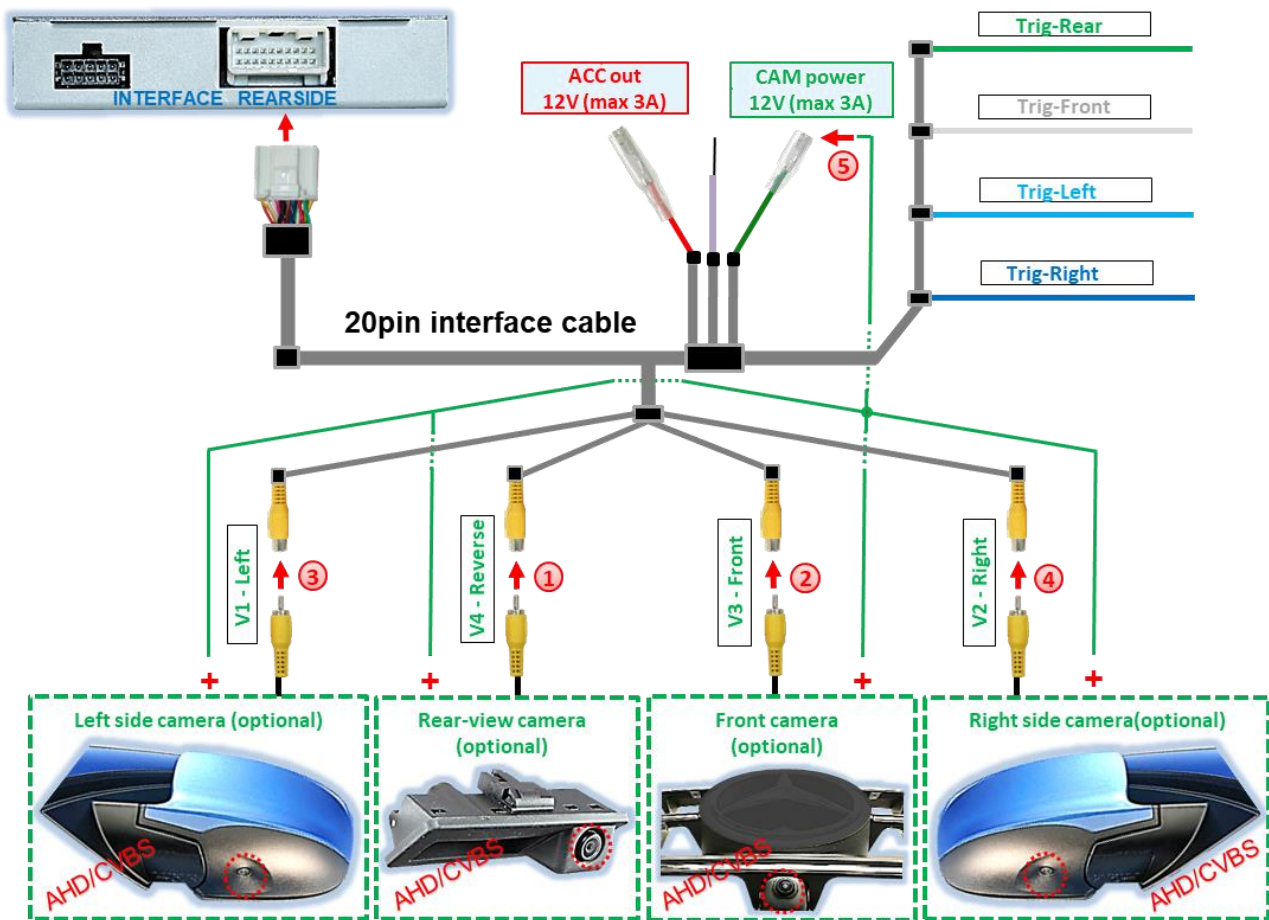

- ① Connect male RCA connector of rear-view camera to female RCA connector **V4-Reverse** of 20pin interface cable.
- ② Connect male RCA connector of front camera to female RCA connector **V3-Front** of 20pin interface cable.
- ③ Connect male RCA connector of left side-camera to female RCA connector **V1-Left** of 20pin interface cable.
- ④ Connect male RCA connector of right side-camera to female RCA connector **V2-Right** of 20pin interface cable.
- ⑤ Connect power supply for all after-market cameras to **green wire CAM power +12V (max 3A)** of 20pin interface cable.



**Note:** The type of camera switching (by CAN-bus or trigger cables) can be preset in the OSD-menu settings individually for each input.

**Attention!**  
Video signal type of each video-source must be preset in OSD-menu of corresponding video-input

### 2.5.2 Connection and power-supply - video-sources rear-view camera, front camera and 2 video-sources

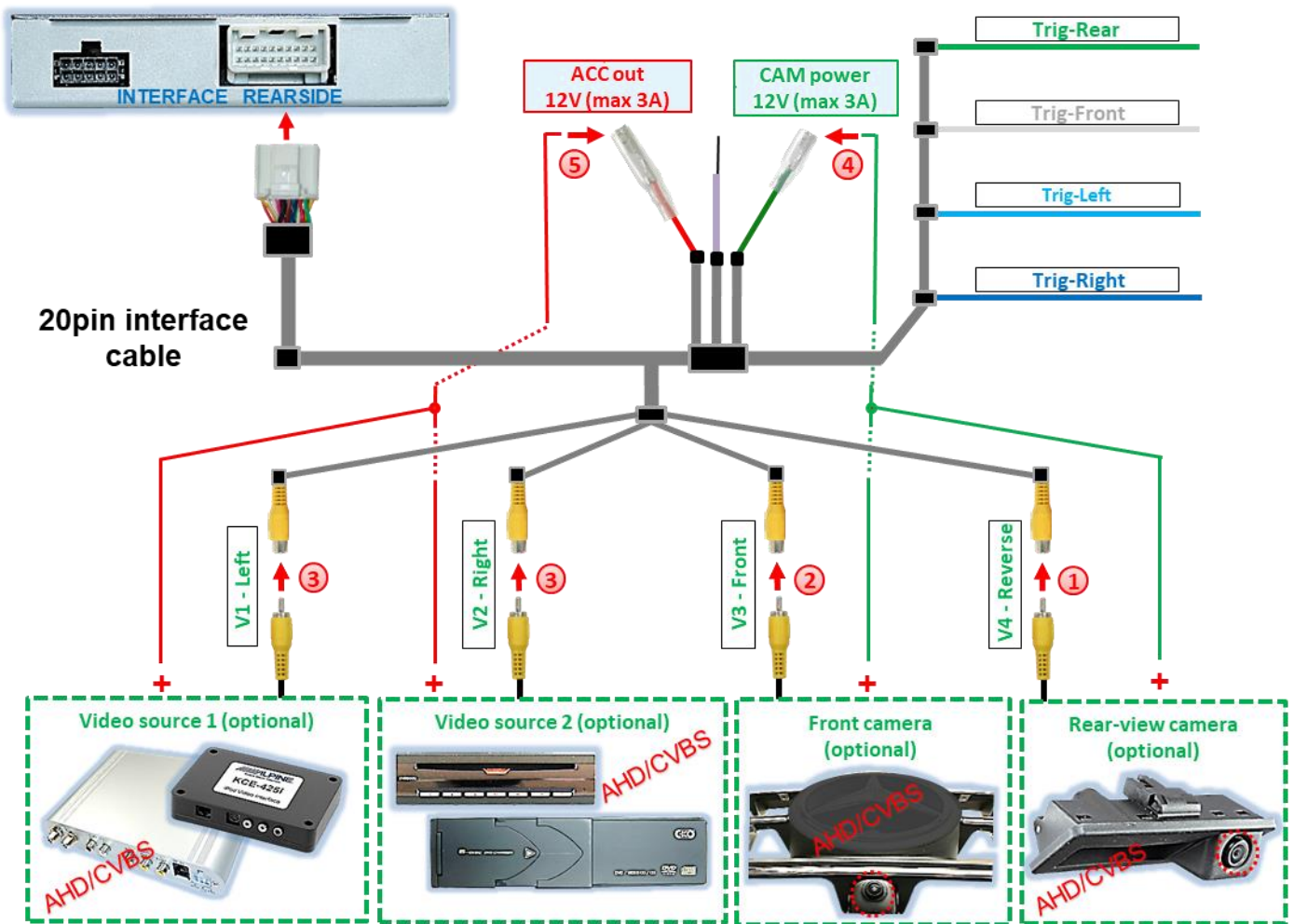

- ① Connect male RCA connector of rear-view camera to female RCA-connector **V4-Reverse** of 20pin interface cable.
- ② Connect male RCA connector of front camera to female RCA-connector **V3-Front** of 20pin interface cable.
- ③ Connect male RCA connectors of video-source 1 and 2 to female RCA connectors **V1-Left** and **V2 Right** of 20pin interface cable.
- ④ Connect power supply for after-market cameras to **green cable CAM power +12V (max 3A)** of 20pin interface cable.
- ⑤ Connect power supply for other video-sources to **red cable ACC out +12V (max 3A)** of 20pin interface cable.



**Note:** The type of camera switching (by CAN-bus or trigger cables) can be preset in the OSD-menu settings individually for each input.

**Attention!**  
Video signal type of each video-source must be preset in OSD-menu of corresponding video-input

### 2.6 After-market rear-view camera

Automatic switching to rear-view camera is possible by CAN-bus or by analogue reverse signal.

#### 2.6.1 Case 1: Reverse signal by CAN-bus

Basic requirement is that the interface is connected to CAN-bus. Furthermore, vehicle CAN-bus reverse signal and its detection by the interface must be compatible.

If so, interface supplies +12V on **green wire CAM power 12V (max 3A)** of 20pin interface cable while reverse gear is engaged and interface automatically switches to rear-view camera input **V4-Reverse** or **HDMI-input\***.

See also chapter 1.5 Settings - 8dip switch bench (interface functions).

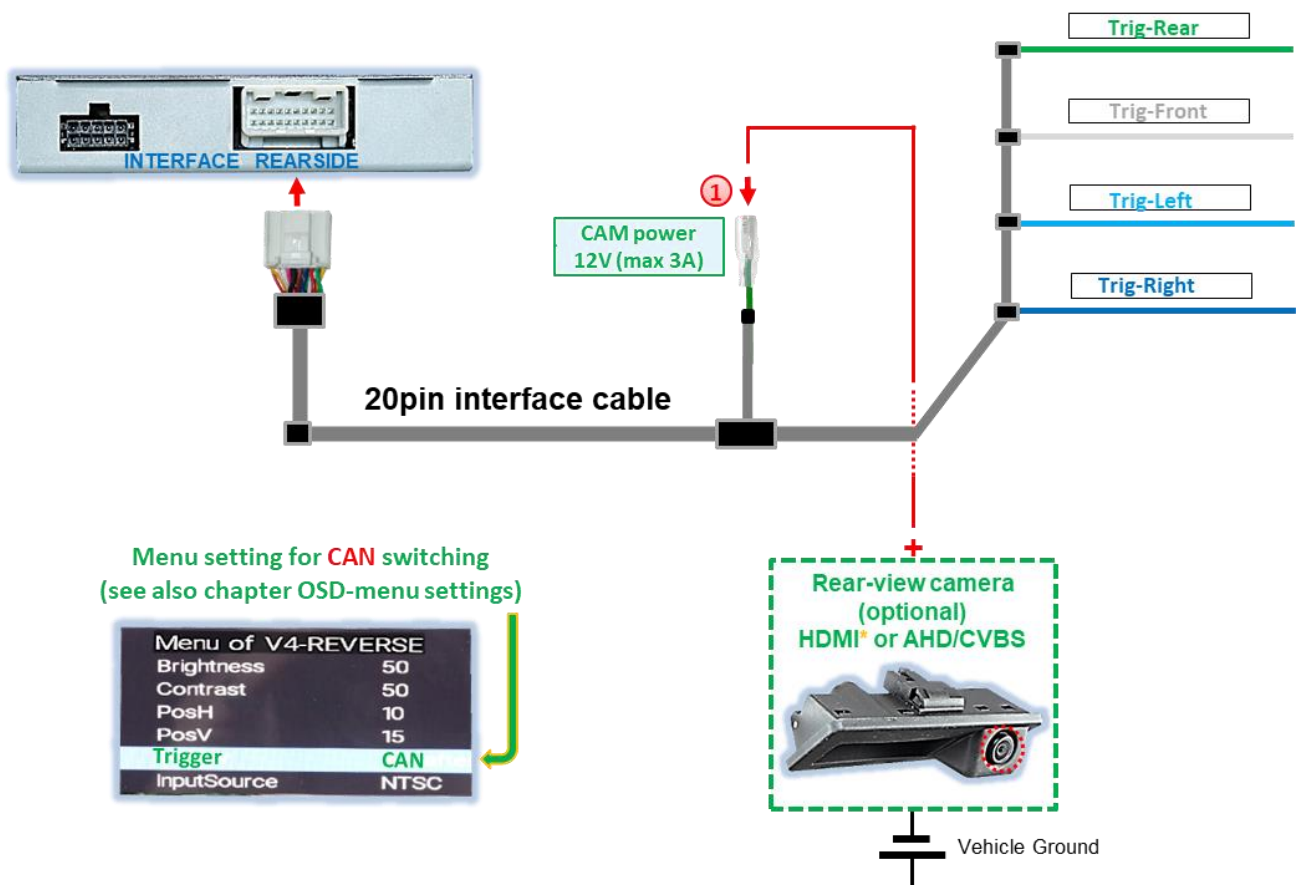

- 1** The +12V (max. 3A) power supply for the rear-view camera can be taken from the **green wire CAM power 12V (max 3A)** of the 20pin interface cable, as it carries voltage only for the time of camera input activation (some cameras are not continuously current-stable).



#### Notes

If **HDMI-input\*** is defined as rear-view camera input by dip 5, **V4-Reverse** input remains without function!

If reverse gear detection of interface by CAN-bus does not work, reverse gear signal has to be connected analogue.

**\* HDMI-input only available on HDV-MBN6**

### 2.6.2 Case 2: Reverse signal analogue connection

If interface does not deliver +12V on **green wire CAM power 12V (max 3A)** of 20pin interface cable when reverse gear is engaged (not all vehicles are compatible), an external switching signal from reverse gear light is required. As the power supply of reverse gear light is not voltage-stabile all the time, a normally open relay (e.g., AC-MR-312 or AC-MR-201) or filter (e.g., AC-PNF-RVC) is required. The diagram below shows the connection with relay.

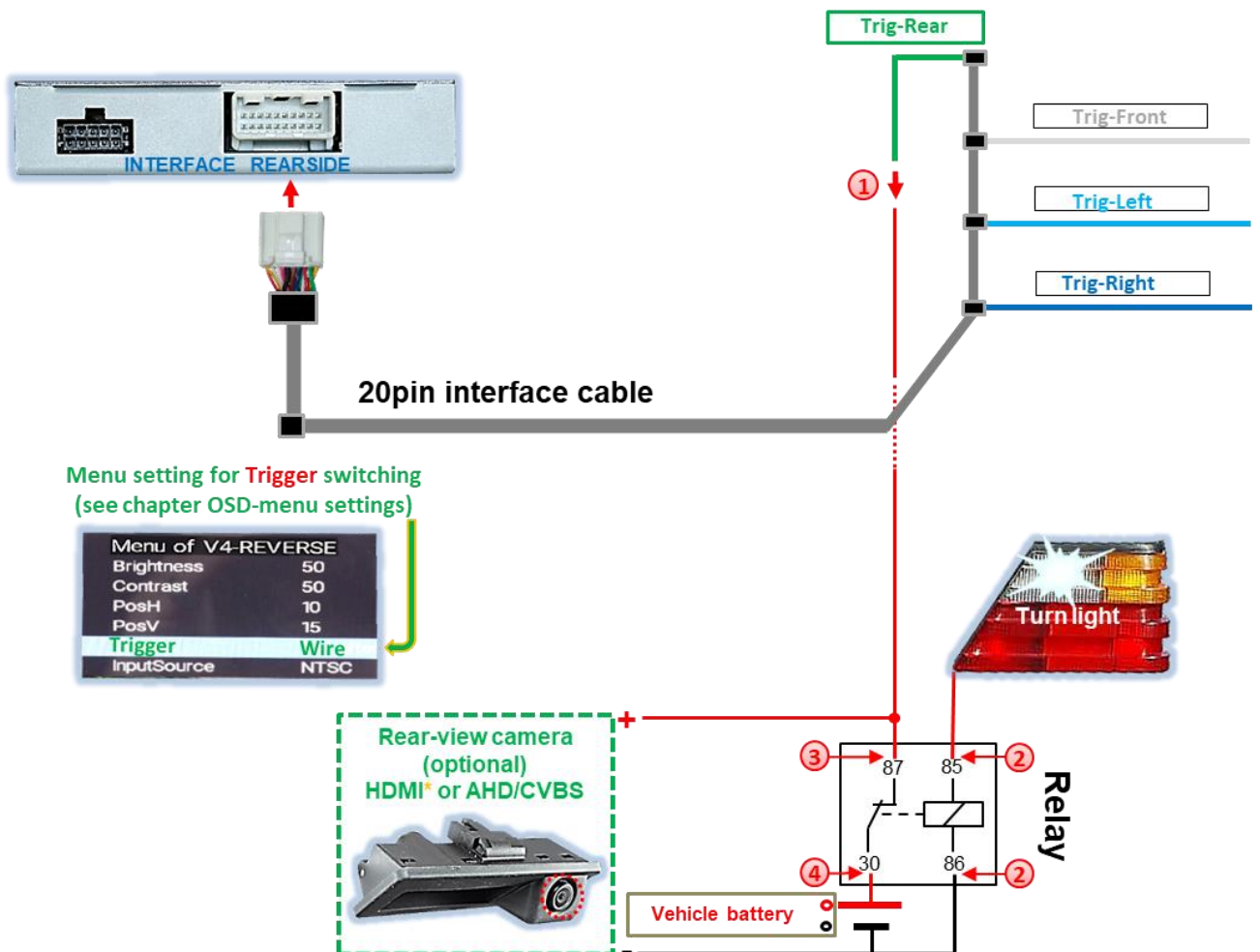

- ① Connect **green wire Trig-Rear** to output connector (87) of relay.
- ② Connect the power cable of vehicle reverse light to relay coil (85) and vehicle ground to relay coil (86).
- ③ Connect output connector (87) of relay to power cable of rear-view camera, additionally to **green wire Trig-Rear**.
- ④ Connect stabile and permanent +12V to input connector (30) of relay.

\* HDMI-input only available on HDV-MBN6



## 2.7 After-market front camera

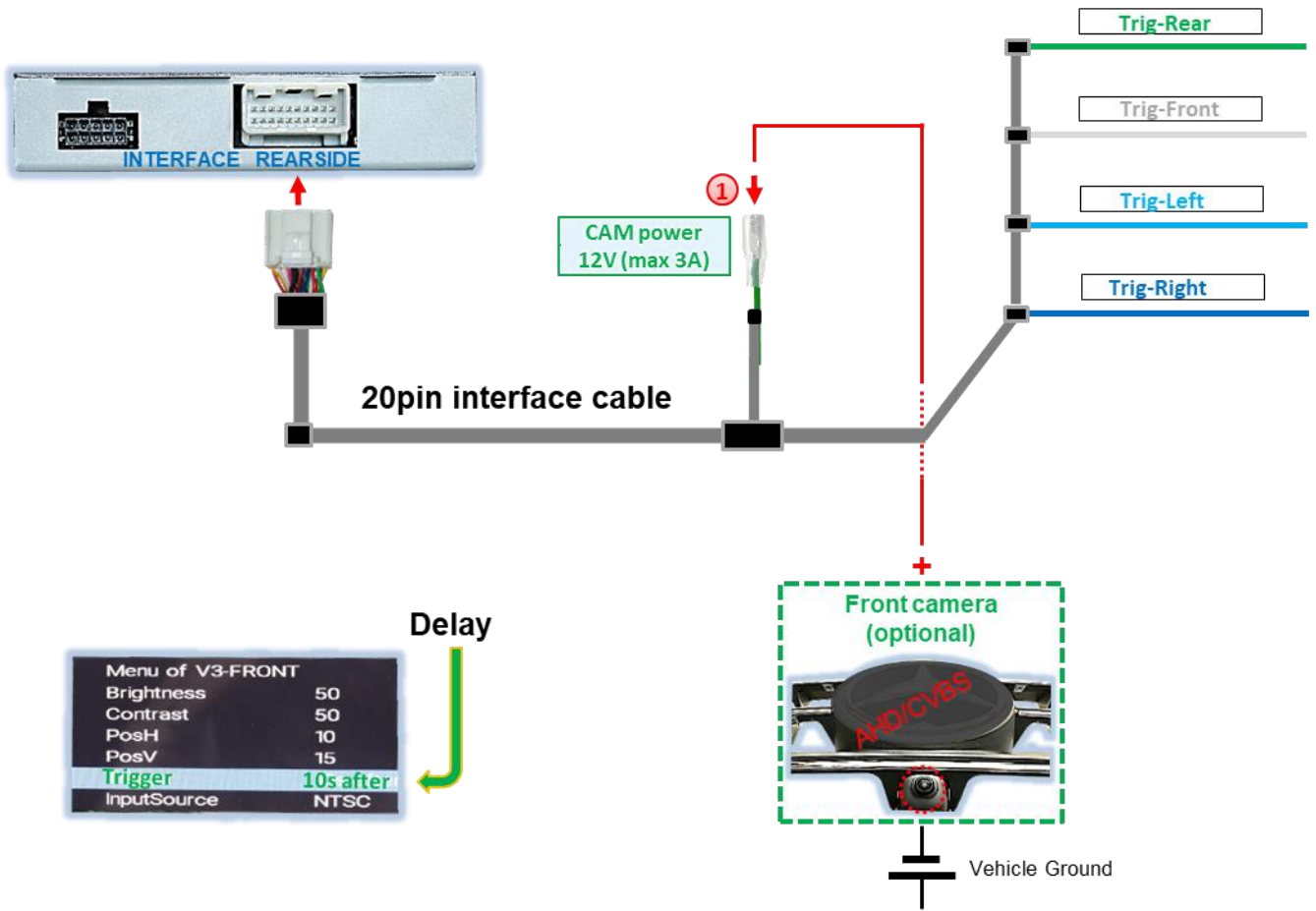

- ① The **green wire CAM power 12V (max 3A)** can be used to supply power to front camera (and all other cameras connected to the video inputs), as it only carries current for the duration of any camera activation (some cameras are not continuously current-stable). Requirement is dip 3 = **ON** (black 8dip switch bench). Then **green wire** carries +12V (max 3A) as power supply for the front camera as long as the front camera input is displayed. The time of display delay can be selected individually for **5, 10, 15** or **20** seconds in the front camera OSD-menu settings.

Switching to front camera after disengaging reverse gear for the time set in the OSD-menu, takes place both, with connection by vehicle CAN-bus and with analogue connection of the rear camera.



**Note:** In addition, manual switching to front camera input (short press) is possible by external button from any image mode (see chapter 3 Interface operation).

### 2.8 After-market side-cameras

Side-cameras can be connected with switching by CAN-bus or analogue.

#### 2.8.1 Case 1: Turn signal from CAN-bus

Basic requirement is that the connection is made with CAN-bus. Furthermore, vehicle CAN-bus reverse signal and its detection must be compatible with the interface.

If so, interface supplies +12V on **green wire CAM power 12V (max 3A)** of 20pin interface cable for the duration of turn signal operations.

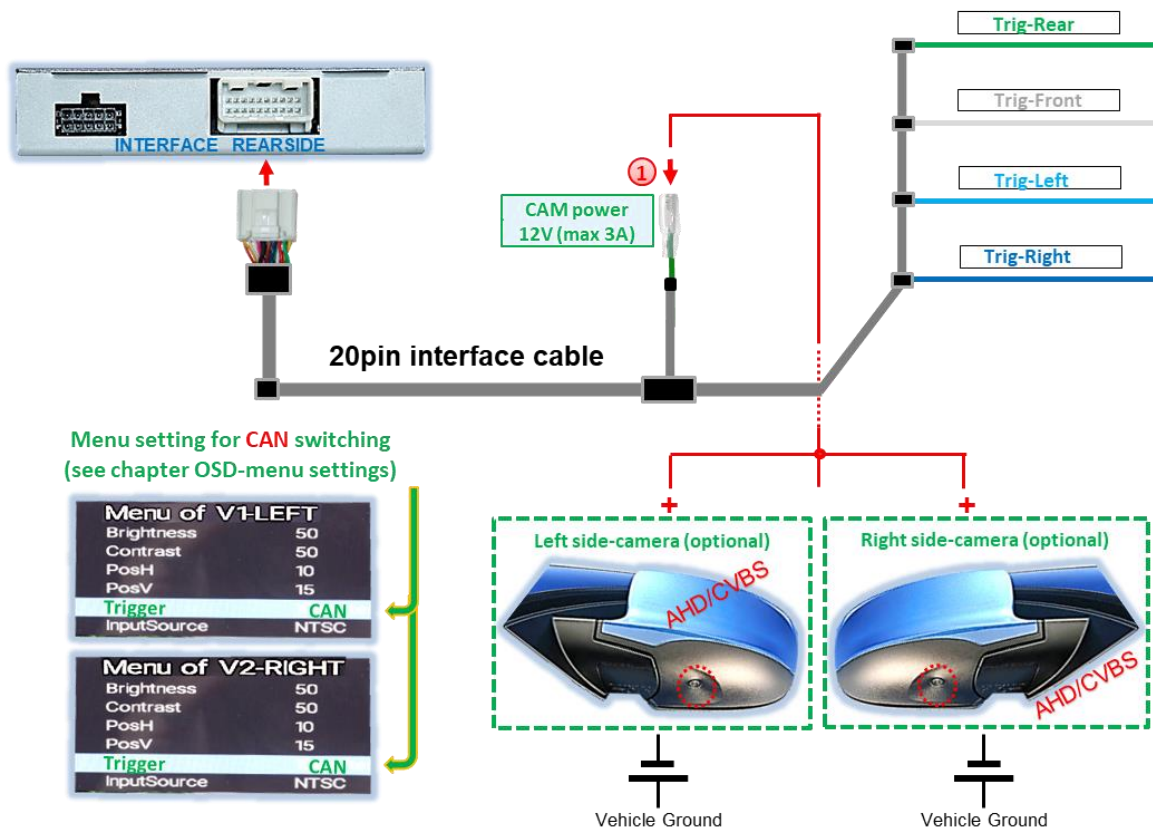

- 1 Power supply for side-cameras should be connected to **green wire CAM power 12V (max 3A)** of 20pin interface cable, as this cable is only powered during camera activation (some cameras are not continuously current stable).



**Note:** If turn signal detection of interface is not compatible with the vehicle CAN-bus, the turn signals must be connected analogue.



## 2.8.2 Case 2: Turn signal analogue connection

With analogue connection, e.g., because signals from the vehicle CAN-bus are not recognised, the analogue switching is possible the two +12V trigger input wires **Trig-Left** and **Trig-Right**. For switching to the side-camera inputs, an external switching signal from the turn signal bulb is required. Since the turn signal may contain electronic interference, for each input, a normally open relay (e.g., AC-RW-1230 with wiring AC-RS5) or a noise filter (e.g., AC-PNF-RVC) is required. The diagram below shows the connection of a normally open relay.

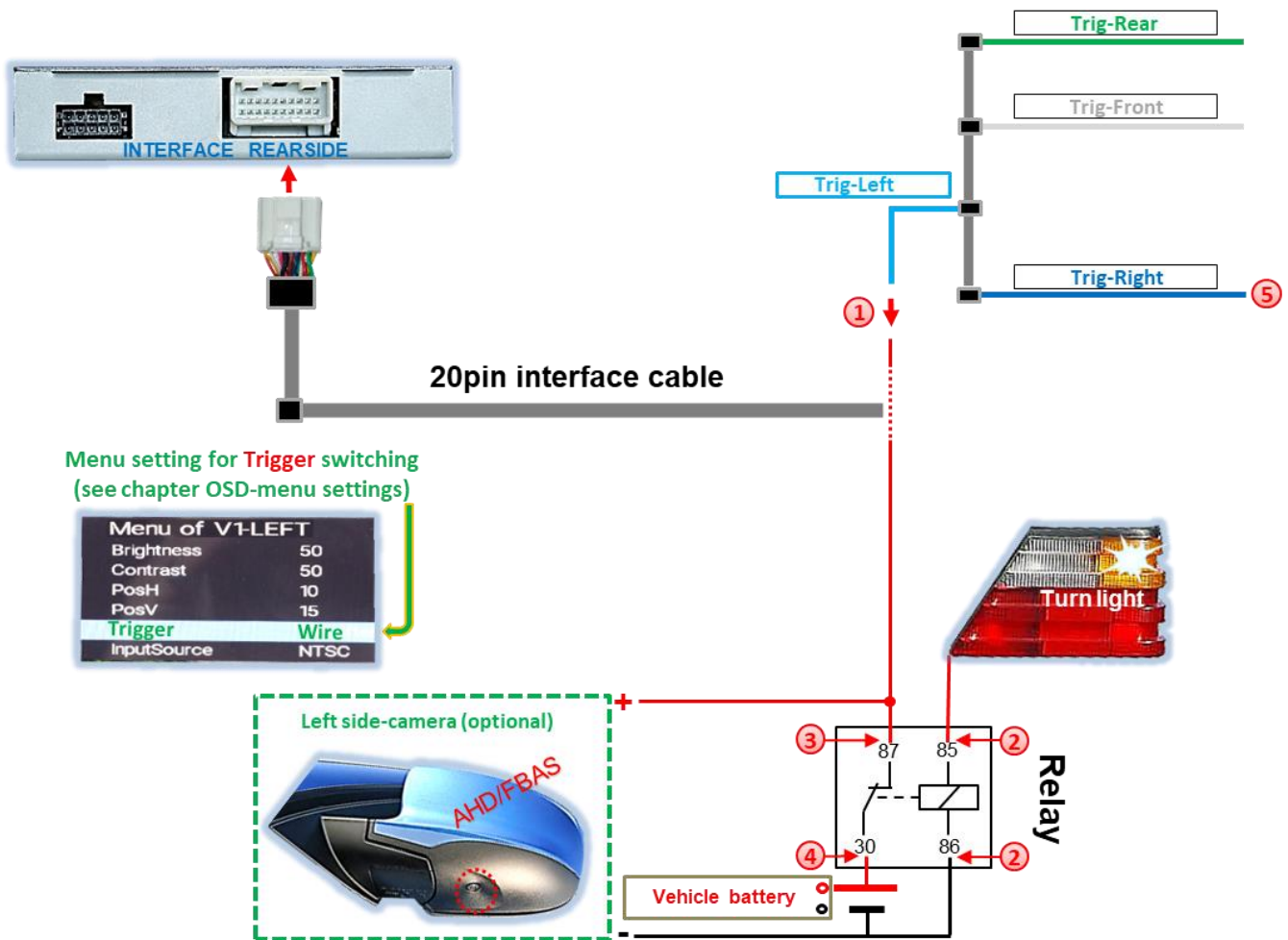

- ① Connect **light blue wire Trig-Left** to output connector (87) of relay.
- ② Connect power-cable of left turn signal to coil (85) of relay and coil (86) of relay to vehicle ground.
- ③ Connect output connector (87) of relay to power cable of rear-view camera, additionally to **light blue wire Trig-Left**.
- ④ Connect stable and permanent +12V to input connector (30) of relay.
- ⑤ Same connection applies to right side-camera just the **dark blue wire Trig-Right**.

## 2.9 HDMI rear-view camera or other HDMI-source (only HDV-MBN6)

The **HDMI-input\*** of the interface can generally be used for any video-source with HDMI-output, connected to it, e.g., rear-view camera, 360° camera-system or other video-source such as smartphones, laptop, streaming stick, DVB-T2 tuner, etc.

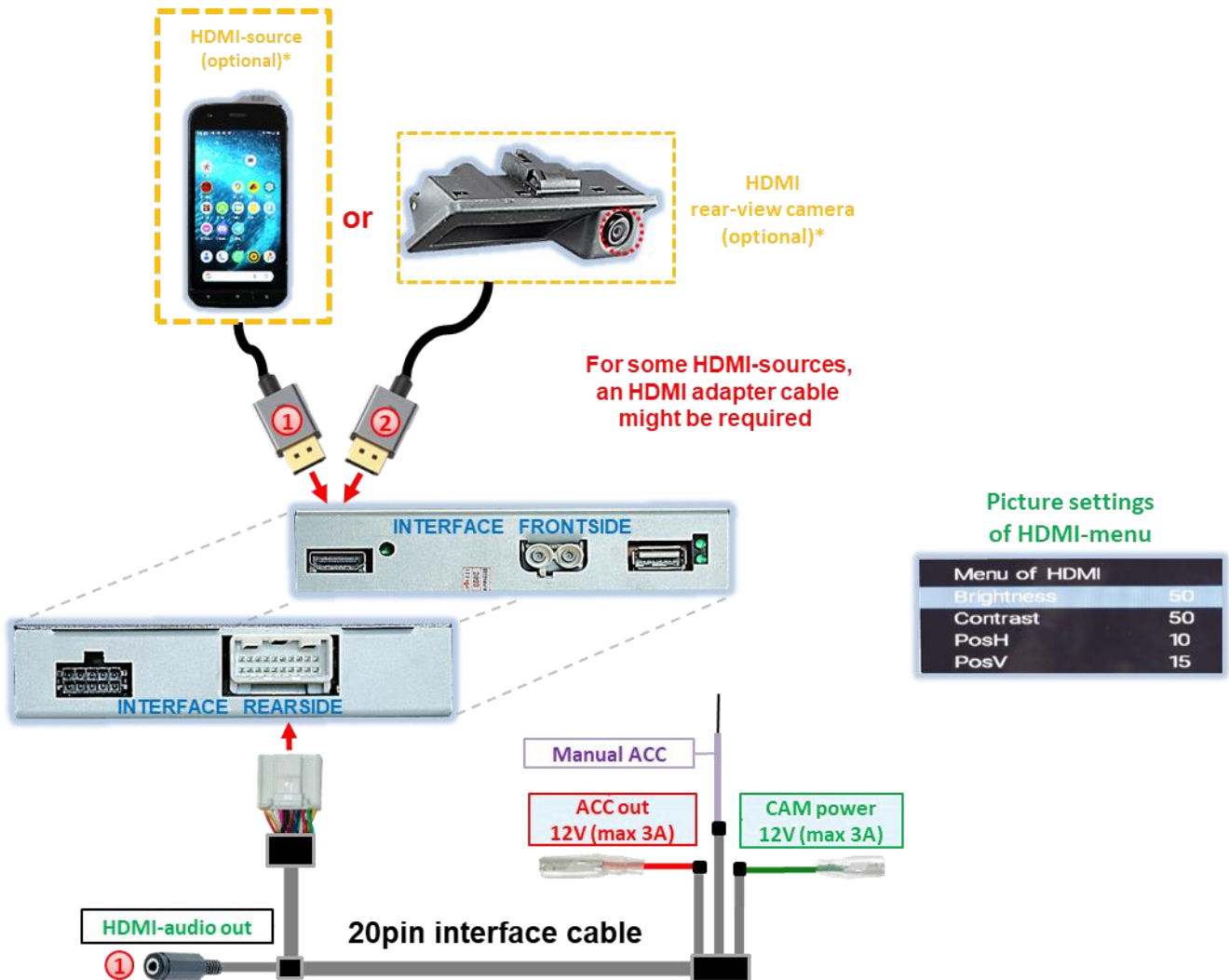

- 1** If an optional HDMI video-source (e.g., smartphone, laptop, etc.) is connected to the **HDMI-input\***, the video shown on the display of the HDMI-source will be mirrored on the vehicle monitor. The video-signal from display-free sources (e.g., streaming stick, DVD-Player, DVB-T2 Tuner, etc.) will be displayed on the vehicle monitor. The power supply for the video-source can be taken from **red wire ACC out 12V (max 3A)**. Received audio signals will only be supplied by the female 3.5 mm jack connector **HDMI-Audio out\*** of the 20pin interface cable. See following chapter 2.10 Audio-insertion.
- 2** If a rear-view camera or 360° camera-system is connected to the **HDMI-input\*** (switched to by CAN-bus or analogue), the image displayed while reverse gear is engaged, and the image of a front camera connected to **V3-Front** is also displayed for the preset time when reverse gear is disengaged. Power supply can be taken from **green wire CAM power 12V (max3A)**.

\* **HDMI-input only available on HDV-MBN6**

## 2.10 Audio-insertion

The interface can only insert video-signals into the factory infotainment. Audio signals of the **HDMI-input\*** are supplied through the 3.5 mm female jack connector **HDMI-Audio out\*** of the interface. For all AV-sources connected to the interface, their audio output must be connected factory AUX input or an optional audio-inserter (e.g., AUX-UNI0x, FM modulator). If several AV-sources are connected to the infotainment, an audio-switch might be required additionally.

Inserted video-signal can be switched simultaneously to any audio mode of the factory infotainment.

\* **HDMI-input only available on HDV-MBN6**

## 2.11 Connection - Interface and external keypad

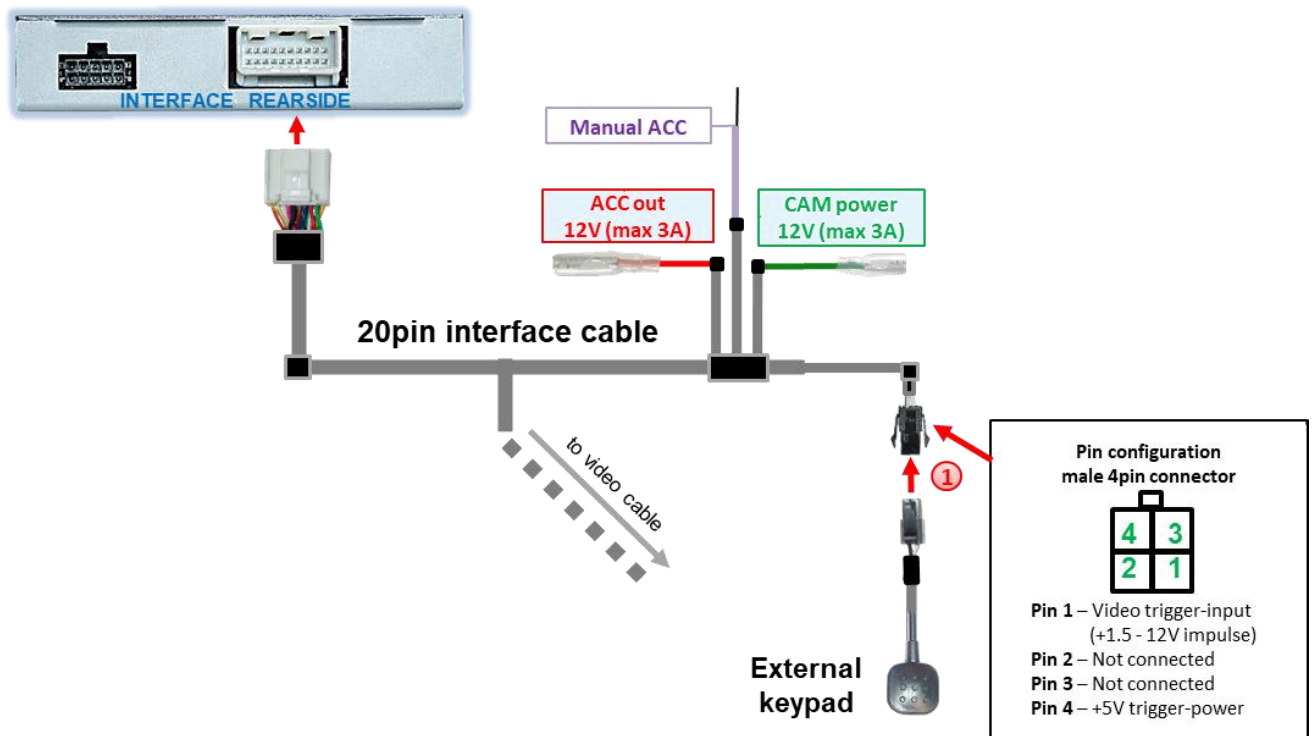

1 Connect female 4pin connector of keypad to male 4pin connector of **20pin interface cable**.



**Note:** We recommend to install the external keypad for possible support reasons even if not required for customer needs. Make sure the external keypad is not installed “pressed” then.

## 2.12 OSD-menu settings

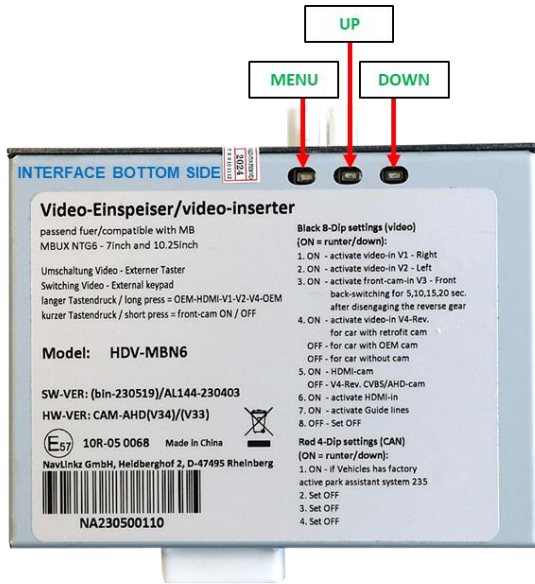

**Attention!**  
Video signal type of each video-source must be preset in OSD-menu of corresponding video-input

OSD-menu settings can be changed by using the 3 keys on rear-side of interface. Pressing MENU key opens the OSD-menu or moves cursor to next menu item. UP (UP) and DOWN (DOWN) change values of current menu item.



**The individual OSD-menu of every video input is only accessible when this input is displayed, regardless of whether a video-source is connected.**

The following setting options are available in the individual OSD-menus of the 5 video inputs:

### Menu of V1-Left (V2-Right)

8dip switch bench dip 1 (dip 2) = ON

Menu of V1-LEFT	
Brightness	50
Contrast	50
PosH	10
PosV	15
Trigger	wire
InputSource	NTSC

Menu of V2-RIGHT	
Brightness	50
Contrast	50
PosH	10
PosV	15
Trigger	wire
InputSource	NTSC

**Brightness** Brightness  
**Contrast** Contrast  
**Pos. H** Horizontal picture position  
**Pos. V** Vertical picture position  
**Trigger** Switching type of video input **V1-Left (V2-Right)**.

**“CAN”-function for side-cameras.** Switching to video input **V1-Left (V2-Right)** when left (right) turn signal of vehicle is activated. Requirement is, that the turn signal is recognised by the interface from vehicle CAN-bus. Manual switching to this input by external button does not work with this setting.

**“Wire”-function for side-cameras or other video-sources without CAN-bus.**

The video input **V1-Left (V2-Right)** is switched to exclusively by **light blue (dark blue)** wire **Trig-Left (Trig-Right)** or manually by the external keypad.

**Input Source** Video-signal type for video-source(s) connected to **V1-Left (V2-Right)**.

This setting **must** be preset for correct video playback.

The following video-source signal types can be selected:

CVBS video-sources: **NTSC, PAL**

AHD video-sources: **720p NTSC, 960p NTSC, 1080p NTSC, 720p PAL, 960p PAL, 1080p PAL**

## Menu of V3-Front

8dip switch bench dip 3 = ON

- Brightness**    Brightness
- Contrast**     Contrast
- Pos. H**        Horizontal picture position
- Pos. V**        Vertical picture position
- Trigger**      Switching type and front camera duration settings for video input **V3-Front**.

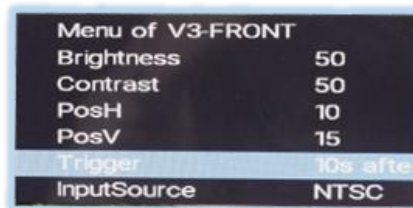

“Delay”-function for front camera. The “delay” setting determines the automatic switching to front camera input after reverse gear is disengaged, as well as its display duration on the display. Adjustable values are 5s after REV, 10s after REV, 15s after REV, 20s after REV are.

“Wire”-function for other video-sources. If another video-source, instead of a front camera, is connected to **V3-Front** input select “Wire”. This shuts off the “delay”-function and the input can be switched to merely by white wire Trig-Front or manually by external keypad.

**Input Source** Video-signal type for video-source connected to **V3-Front**.

This setting **must** be preset for correct video playback.

The following video-source signal types can be used:

CVBS video-sources: **NTSC, PAL**

AHD video-sources: **720p NTSC, 960p NTSC, 1080p NTSC, 720p PAL, 960p PAL, 1080p PAL**

## Menu of V4-Reverse

8dip switch bench dip 4 = ON, dip 5 = OFF, dip 6 = ON/OFF

Input **V4-Reverse** is without function when **HDMI-input\*** is defined as rear-view camera input (dip 5 = ON). But function Trigger of **HDMI-input\*** must be set in menu of **V4-Reverse**.

- Brightness**    Brightness
- Contrast**     Contrast
- Pos. H**        Horizontal picture position
- Pos. V**        Vertical picture position
- Trigger**      Switching type of video input defined as rear-view camera input.

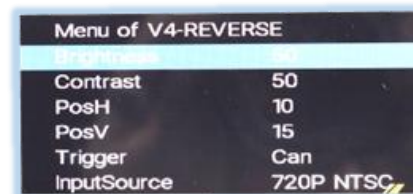

„CAN”-function with CAN-bus connection. With „CAN” setting, on engagement of reverse gear, the interface switches automatically to **V4-Reverse/HDMI\*** for a CVBS/AHD rear-view camera. Requirement is, that the reverse gear signal is recognised by the interface from vehicle CAN-bus.

„Wire”-function with analogue connection. It is always possible to switch by **green Trig-Left wire** to rear-view camera connected to **V4-Reverse/HDMI\***, no matter whether set to „Wire” or „CAN”. If (reverse gear) connection is supposed to be analogue, it is recommended to set this function to „Wire”.

**Input Source** Video-signal type for video-source connected to **V4-Reverse**.

This setting **must** be preset for correct video playback.

The following video-source signal types can be used:

CVBS video-sources: **NTSC, PAL**

AHD video-sources: **720p NTSC, 960p NTSC, 1080p NTSC, 720p PAL, 960p PAL, 1080p PAL**

\* HDMI-input only available on HDV-MBN6



## Menu of HDMI\*

8dip switch bench (dip 4 = ON, dip 5 = **ON/OFF**, dip 6 = ON)

<b>Brightness</b>	Brightness
<b>Contrast</b>	Contrast
<b>Pos. H</b>	Horizontal picture position
<b>Pos. V</b>	Vertical picture position

Menu of HDMI	
Brightness	50
Contrast	50
PosH	10
PosV	15

In the **HDMI**-menu\*, picture settings of an HDMI rear-view camera connected to the **HDMI**-input\* (dip 5 = **ON**) or another HDMI AV-source (dip 5 = **OFF**) source can be adjusted while they are displayed.

The picture resolution of connected HDMI-sources is detected automatically.



**Notes:** Input **V4-Reverse** is without function when **HDMI**-input\* is defined as rear-view camera input (dip 5 = **ON**). But the function "Trigger" of **HDMI**-input\* must be set in menu of **V4-Reverse**.

\* **HDMI**-input only available on **HDV-MBN6**

## 3 Interface operation

The external keypad of the can be used to switch alle enabled inputs except the input defined for rear-view camera.

- Long press of keypad (2-3 seconds)

Long press of external keypad (2-3 seconds), switches from factory video to inserted first enabled interface video-input. Any additional long press switches to the next enabled interface video-input and after last back to factory video. Disabled inputs are skipped.

If all inputs are enabled by the corresponding dip-switches, the order is as follows:

- *Factory video* → **HDMI\*** → **V1-Left** → **V2-Right** → *factory video*

**Note:** The interface only switches after releasing the switch (after long press).

**\* HDMI-input only available on HDV-MBN**

- Short press of keypad (only if dip 3 is set to ON)

Short press of external keypad, switches from any video mode to front camera input **V3-Front** and next short press switches back to the previous video mode.

**Note:** We recommend to install the external keypad for possible support reasons even if not required for customer needs. Make sure the external keypad is not installed “pressed” then.

## 4 Specifications

BATT/ACC range	9V - 16V
Stand-by power drain	about 6mA
Power consumption	310mA @12V
Video input	0.7V - 1V
Video input signal types	CVBS/AHD/ <b>HDMI (HDV-version only)</b>
Signal standards CVBS/AHD	NTSC/PAL
Temperature range	-40°C to +85°C
Dimensions video-box	115 x 25 x 109 mm (W x H x D)

## 5 FAQ - Troubleshooting interface functions - product-specific

Problem	Possible reasons	Solution
Distorted or no inserted video	Video-signal type of video-source not defined in OSD-menu of the corresponding video input	See chapter 2.12 <i>OSD-menu settings</i> - menu of corresponding input

## 6 FAQ - Trouble shooting Interface functions - general

For any troubles which may occur, check the following table for a solution before requesting support from your vendor.

Symptom	Reason	Possible solution
No picture/black picture (factory picture).	Not all connectors have been reconnected to factory head-unit or monitor after installation.	Connect missing connectors.
	No power on CAN-bus box (all LED CAN-bus box are off).	Check power supply of CAN-bus box. Check CAN-bus connection of CAN-bus box.
	CAN-bus box connected to CAN-bus in wrong place.	Refer to the manual where to connect to the CAN-bus. If not mentioned, try another place to connect to the CAN-bus.
	No power on video-interface (all LED video-interface are off).	Check whether CAN-bus box delivers +12V ACC on red wire output of 8pin to 6pin cable. If not cut wire and supply ACC +12V directly to video-interface.
No picture/black picture/white picture (inserted picture) but factory picture is OK.	No picture from video source.	Check on other monitor whether video source is OK.
	No video-source connected to the selected interface input.	Check settings dips 1 to 3 of video interface which inputs are activated and switch to corresponding input(s).
	LVDS cables plugged in wrong place.	Double-check whether order of LVDS cables is exactly connected according to manual. Plugging into head-unit does not work when the manual says to plug into monitor and vice versa.
Inserted picture totally wrong size or position.	Wrong monitor settings of video-interface.	Try different combinations of dips 7 and 8 of video-interface. Unplug 6pin power after each change.
Inserted picture double or 4 times on monitor.		
Inserted picture distorted, flickering or running vertically.	Video sources output set to AUTO or MULTI which causes a conflict with the interfaces auto detection.	Set video source output fixed to PAL or NTSC. It is best to set all video sources to the same standard.
	If error occurs only after source switching: Connected sources are not set to the same TV standard.	Set all video sources to the same standard.
	Some interfaces can only handle NTSC input.	Check manual whether there is a limitation to NTSC mentioned. If yes, set source fixed to NTSC output.
Inserted picture b/w.		
Inserted picture qual. bad.		
Inserted picture size slightly wrong.	Picture settings have not been adjusted.	Use the 3 buttons and the interface's OSD to adjust the picture settings for the corresponding video input.
Inserted picture position wrong.		
Camera input picture flickers.	Camera is being tested under fluorescent light which shines directly into the camera.	Test camera under natural light outside the garage.
Camera input picture is bluish.	Protection sticker not removed from camera lens.	Remove protection sticker from lens.

Symptom	Reason	Possible solution
Camera input picture black.	Camera power taken directly from reverse gear lamp.	Use relay or electronics to "clean" reverse gear lamp power. Alternatively, if CAN-bus box is compatible with the vehicle, camera power can be taken from green wire of 6pin to 8pin cable.
Camera input picture has distortion.		
Camera input picture settings cannot be adjusted.	Camera input picture settings can only be adjusted in AV2 mode.	Set dip 3 of video-interface to ON (if not input AV2 is not already activated) and connect the camera to AV2. Switch to AV2 and adjust settings. Reconnect camera to camera input and deactivate AV2 if not used for other source.
Graphics of a car in camera input picture.	Function PDC is ON in the interface OSD.	In compatible vehicles, the graphics will display the factory PDC distance. If not working or not wanted, set interface OSD menu item UI-CNTRL to ALLOFF.
Chinese signs in camera input picture	Function RET or ALL is ON (function for Asian market) in the interface OSD.	Set interface OSD menu item UI-CNTRL to ALLOFF or PDCON.
Not possible to switch video sources by OEM button.	CAN-bus interface does not support this function for vehicle.	Use external keypad or cut white wire of 6pin to 8pin cable and apply +12V impulses for AV-switching.
	Pressed too short.	For video source switching a longer press of about 2.5 seconds is required.
Not possible to switch video sources by external keypad.	SW-version of interface does not support external keypad.	Use OEM-button or cut white wire of 6pin to 8pin cable and apply +12V impulses for AV-switching.
	Interface does not switch to camera input when reverse gear is engaged.	CAN-bus interface does not support this function for the vehicles.
Interface switches video-sources by itself.	CAN-bus interface compatibility to vehicle is limited.	Cut the grey wire of 6pin to 8pin and isolate both ends. If problem still occurs, additionally cut the white wire of 6pin to 8pin cable and isolate both ends.

## 7 Technical Support

Please note that direct technical support is only available for products purchased directly from NavLinkz GmbH. For products bought from other sources, contact your vendor for technical support.

**NavLinkz GmbH**  
**Distribution/Tech dealer-support**  
Heidberghof 2  
D-47495 Rheinberg

Tel +49 2843 17595 00

Email [mail@navlinkz.de](mailto:mail@navlinkz.de)



10R-06 5485



Made in China

