

## Video-inserter RL3-A15



**Compatible with  
Mercedes vehicles with Audio15 systems  
VW vehicles with RNS6000 systems**

**Video-inserter with 2 video inputs + rear-view camera input**

### Product features

- Video-inserter for factory infotainment monitors
- 2 CVBS video-inputs for after-market devices (e.g. DVD-Player, DVB-T tuner, ...)
- Rear-view camera video-input
- Automatic switching to rear-view camera input on engagement of reverse gear
- Video-in-motion in drive mode (ONLY for connected video-sources)
- Compatible with factory rear-view camera
- AV-inputs NTSC compatible

## Contents

### 1. Prior to installation

- 1.1. Delivery contents
- 1.2. Checking the compatibility of vehicle and accessories
- 1.3. The video interface's connectors
- 1.4. Settings of the 8 Dip switches (black)
  - 1.4.1. Enabling the interface's video inputs (dip 2-3)
  - 1.4.2. Rear-view camera setting (dip 5)
- 1.5. Settings of the 4 Dip switches (CAN function – red)

### 2. Installation

- 2.1. Place of installation – video interface
- 2.2. Place of installation – daughter PCB
- 2.3. Connection schema
- 2.4. Connection – Ribbon cables
  - 2.4.1. Warning notes, concerning the installation of ribbon cables
- 2.5. 20pin RGB digital cable – Connection and wiring
- 2.6. Connection - head-unit-power connection
- 2.7. Connection – purple wire
- 2.8. Connection - video sources
  - 2.8.1. After-market rear-view camera
- 2.9. Connection – external keypad
- 2.10. Picture settings

### 3. Interface operation – external keypad

### 4. Specifications

### 5. FAQ – Trouble shooting

### 6. Technical support

## Legal Information

By law, watching moving pictures while driving is prohibited, the driver must not be distracted. We do not accept any liability for material damage or personal injury resulting, directly or indirectly, from installation or operation of this product. Apart from using this product in an unmoved vehicle, it should only be used to display fixed menus or rear-view-camera video when the vehicle is moving (for example the MP3 menu for DVD upgrades).

Changes/updates of the vehicle's software can cause malfunctions of the interface. Up to one year after purchase we offer free software-updates for our interfaces. To receive a free update, the interface has to be sent in at own cost. Wages for de-and reinstallation and other expenditures involved with the software-updates will not be refunded.

## 1. Prior to installation

Read the manual prior to installation. Technical knowledge is necessary for installation. The place of installation must be free of moisture and away from heat sources.

### 1.1. Delivery contents

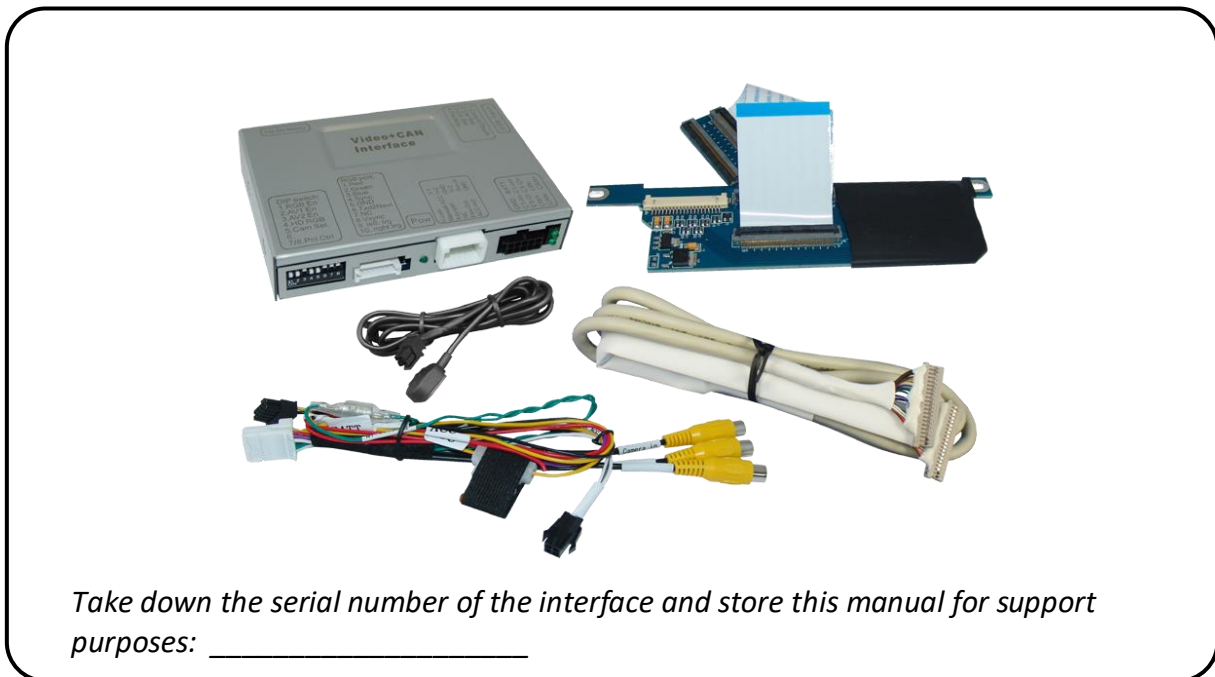



## 1.3. Connection - Video-Interface

The video-interface converts the connected after-market sources video signals into an RGB digital signal which is inserted in the factory monitor using separate trigger options and it reads vehicle's digital signals out of the vehicle's CAN-bus and converts them for the video interface.

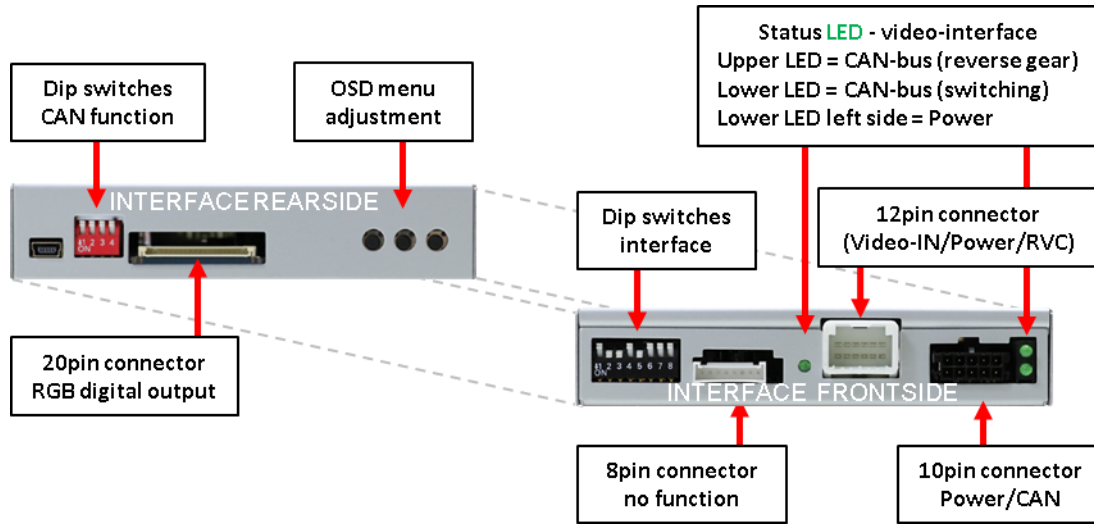

## 1.4. Settings of the 8 Dip switches (black)

Some settings have to be selected by the 8 dip-switches of the video-interface. Dip position down is **ON** and position up is **OFF**.

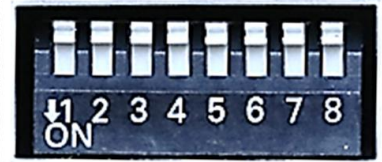

Dip	Function	ON (down)	OFF (up)
1	No function		set to OFF
2	Video 1	enabled	disabled
3	Video 2	enabled	disabled
4	No function		set to OFF
5	Rear-view cam type	after-market	factory or none
6	No function		set to OFF
7	No function		set to OFF
8	No function		Set to OFF

See the following chapters for detailed information.

## 1.4.1. Enabling the interface's video inputs (dip 2-3)

Only the enabled video inputs can be accessed when switching through the interface's video sources. It's recommended to enable only the required inputs for the disabled will be skipped when switching through the video-interfaces inputs.

## 1.4.2. Rear-view camera setting (dip 5)

If set to OFF, the interface switches to factory RGB digital picture while the reverse gear is engaged to display factory rear-view camera or factory optical park system picture.

If set to ON, the interface switches to its rear-view camera input "V4 Reverse" while the reverse gear is engaged.

**Note:** Dip 1, 4, 6, 7 and 8 are out of function and have to be set to **OFF**.

## 1.5. Settings of the 4 Dip switches (CAN function - red)

Dip position down is **ON** and position up is **OFF**.

Navigation / system	Dip 1	Dip 2	Dip 3	Dip 4
Mercedes Audio15 NTG2.5/NTG5-447	OFF	OFF	OFF	OFF
VW RNS6000	OFF	OFF	OFF	OFF



## 2. Installation

**Switch off the ignition and disconnect the vehicle's battery! The interface needs a permanent 12V source. If -according to factory rules- a disconnection of the battery has to be avoided, it should be sufficient to use the vehicle's sleep-mode. In case, the sleep-mode doesn't succeed, the battery has to be disconnected with a resistor lead.**

**The Interface needs a permanent power supply! If power isn't directly taken from the battery, the connection's power has to be checked for being start-up proven and permanent.**

### 2.1. Place of installation – video-interface

The video-interface shall be installed on the backside of the head-unit.

### 2.2. Place of installation – daughter PCB

The daughter PCB is performed to be installed on the rear side of the head unit's monitor instead of the original base plate

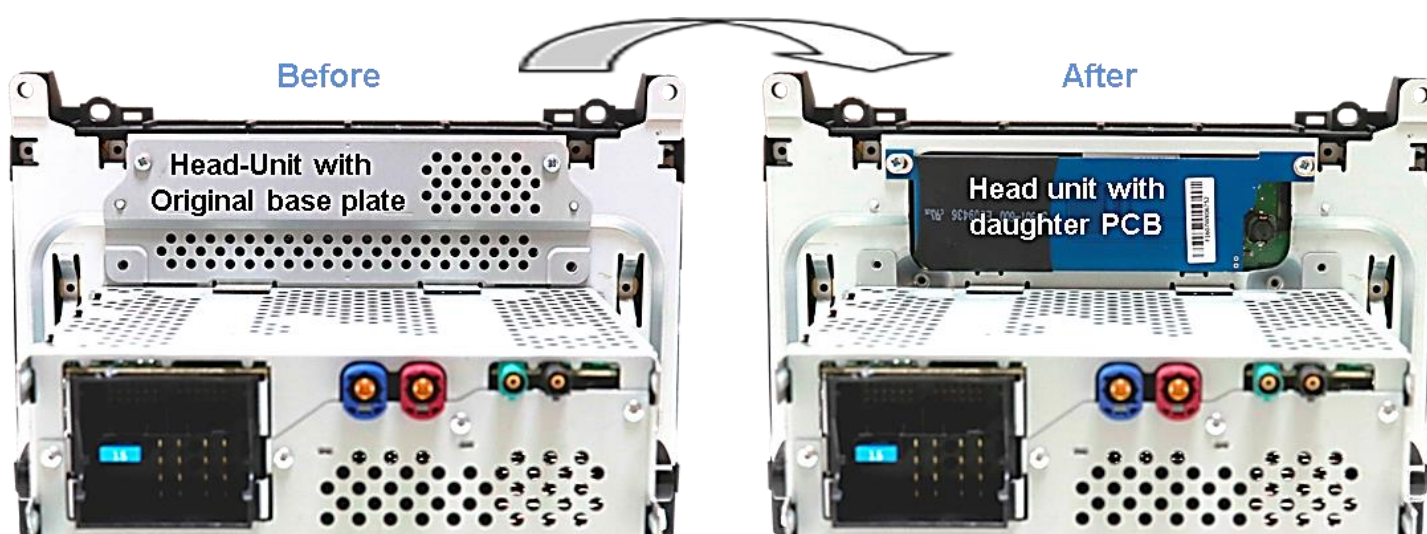



## 2.3. Connection schema

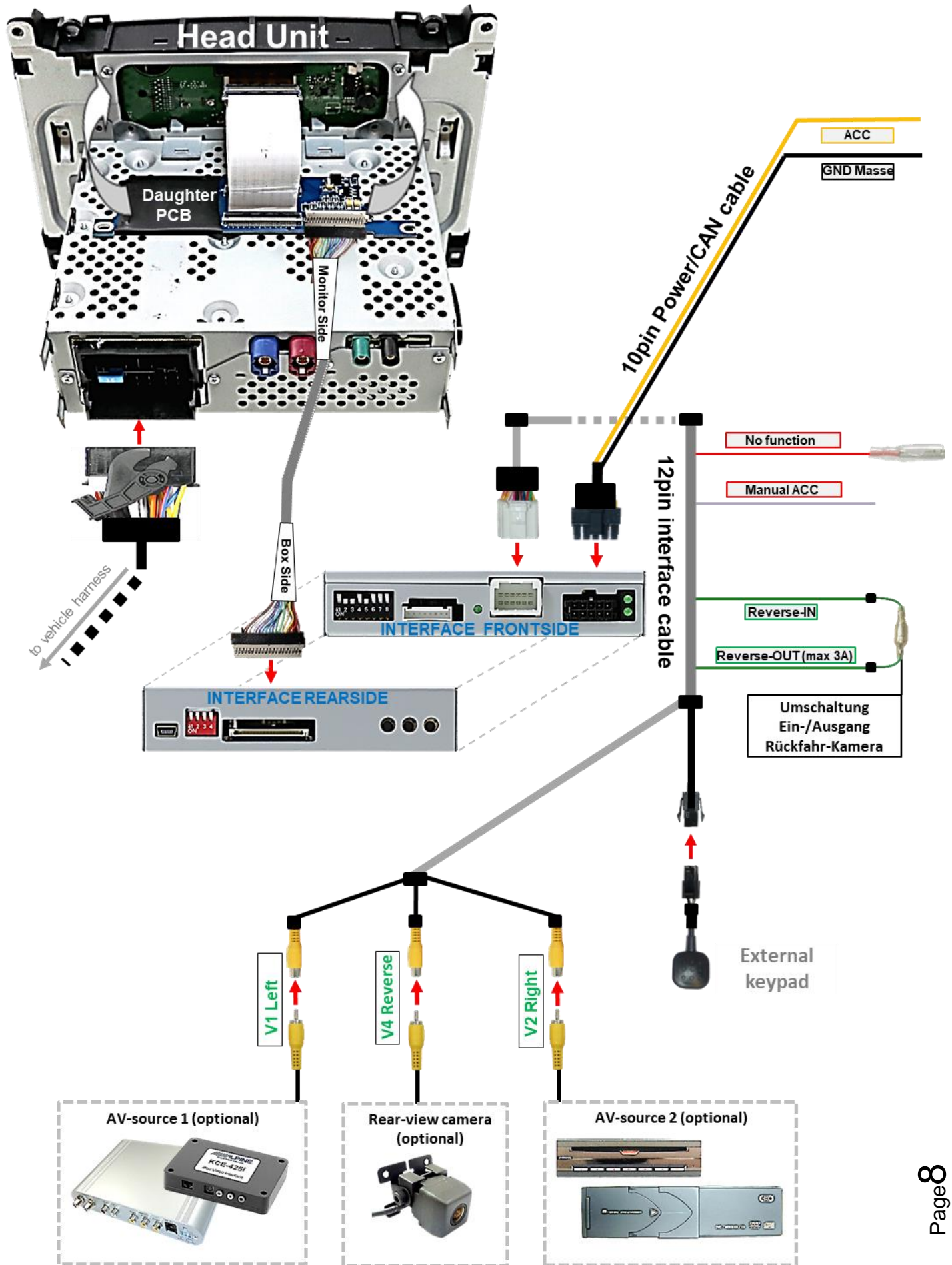



## 2.4. Connection – ribbon cables

Remove the head-unit and further remove the original housing base plate on the rear side of the monitor (4screws), to set free the 40pin ribbon cable.

Copper coloured ribbon cable to outer PCB ribbon cable merger

- 1 Clip out the monitor's original copper coloured 40pin ribbon cable which is connected at the head-unit mainboard's ribbon cable base and connect it to the PCB's outer 40pin ribbon cable merger.

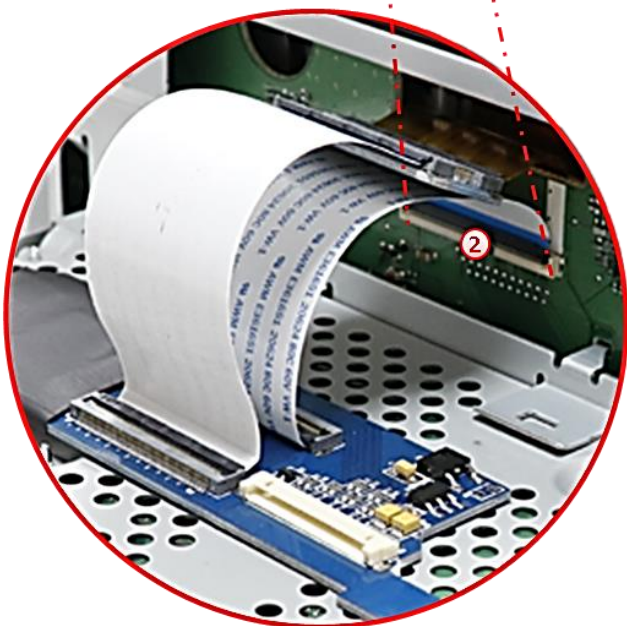
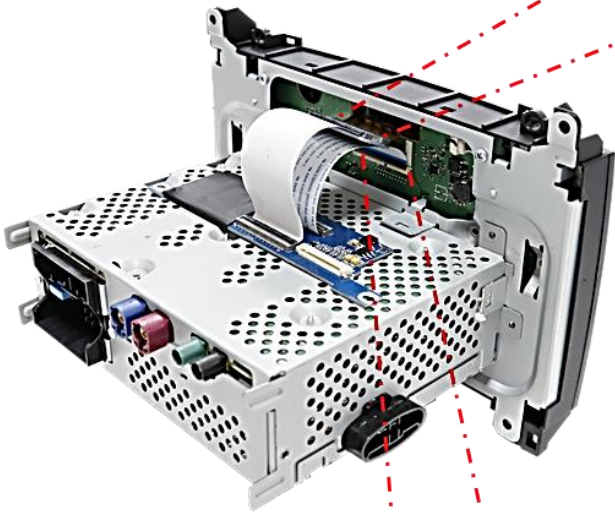
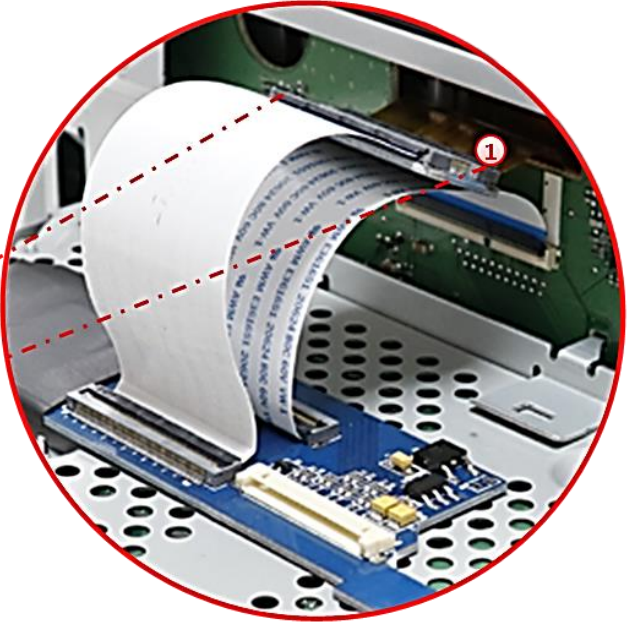

- 2 Connect the daughter PCB's pre-assembled inner 40pin ribbon cable to the previously become free ribbon cable base of the monitor mainboard.

**Note:** Heed the following warning notes concerning installation of ribbon cables!

Inner short PCB ribbon cable to monitor ribbon cable base

## 2.4.1. Warning notes, concerning the installation of ribbon cables:

- 1) The contacting ends of ribbon cables always have to be installed in a straight and precise 180° position to the connector. Each deviation from a perfect contact position will cause faulty contact and even danger of short circuit
- 2) The ribbon cable's contacting sides always have to correspond to the contacting sides of the connectors, concerning the mounting position.
- 3) Avoid cable contusion or cable injury caused by sharp-edged metal.

## 2.5. 20pin RGB digital cable – connection and wiring

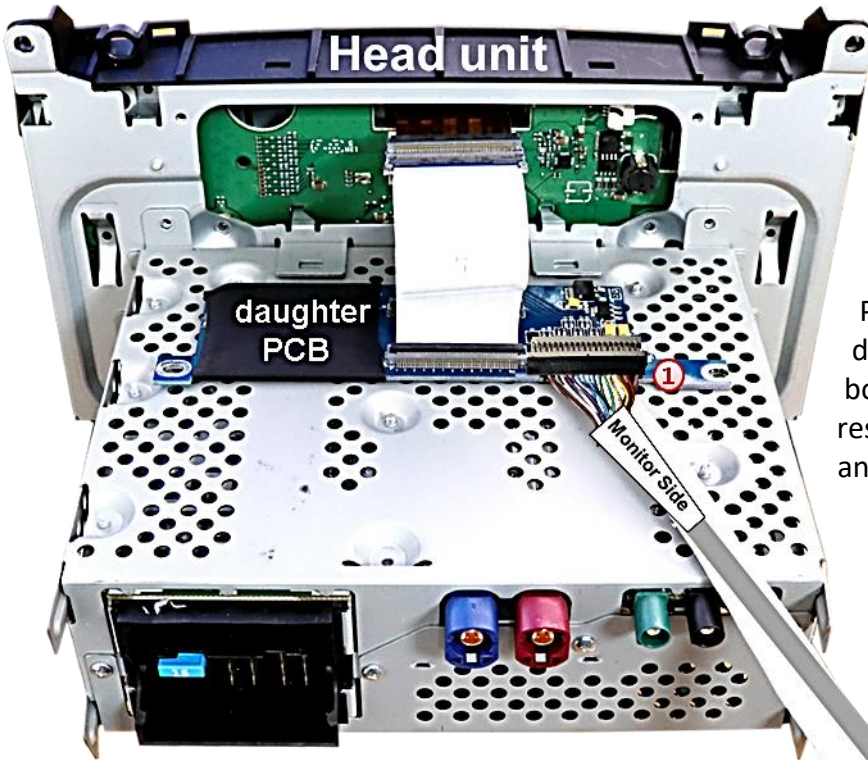

1

Connect the male beige-coloured 20pin connector of the 20pin RGB digital cable to the female 20pin connector of the daughter PCB.

Pay special attention to the cable's direction because its connectors both seem to be identical. (Strictly respect the labels „**MONITOR SIDE**“ and „**BOX SIDE**“).

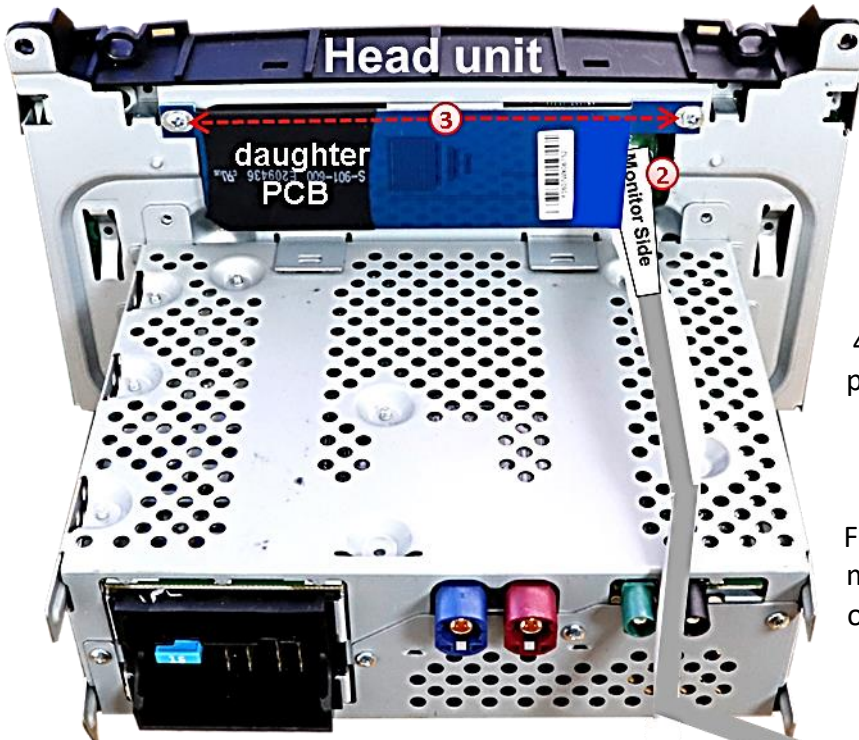
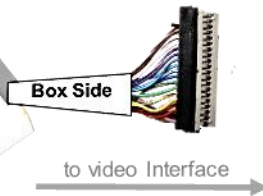

2

Position the daughter PCB at the monitor's rear-side and carefully fold in the installed 40pin ribbon cables into the monitor's housing, after leading out the grey coloured 40pin RGB digital cable at a suitable place.

3

Fix the daughter PCB to the monitor's housing by using both original screws.





## 2.6. Connection – Head unit-Power

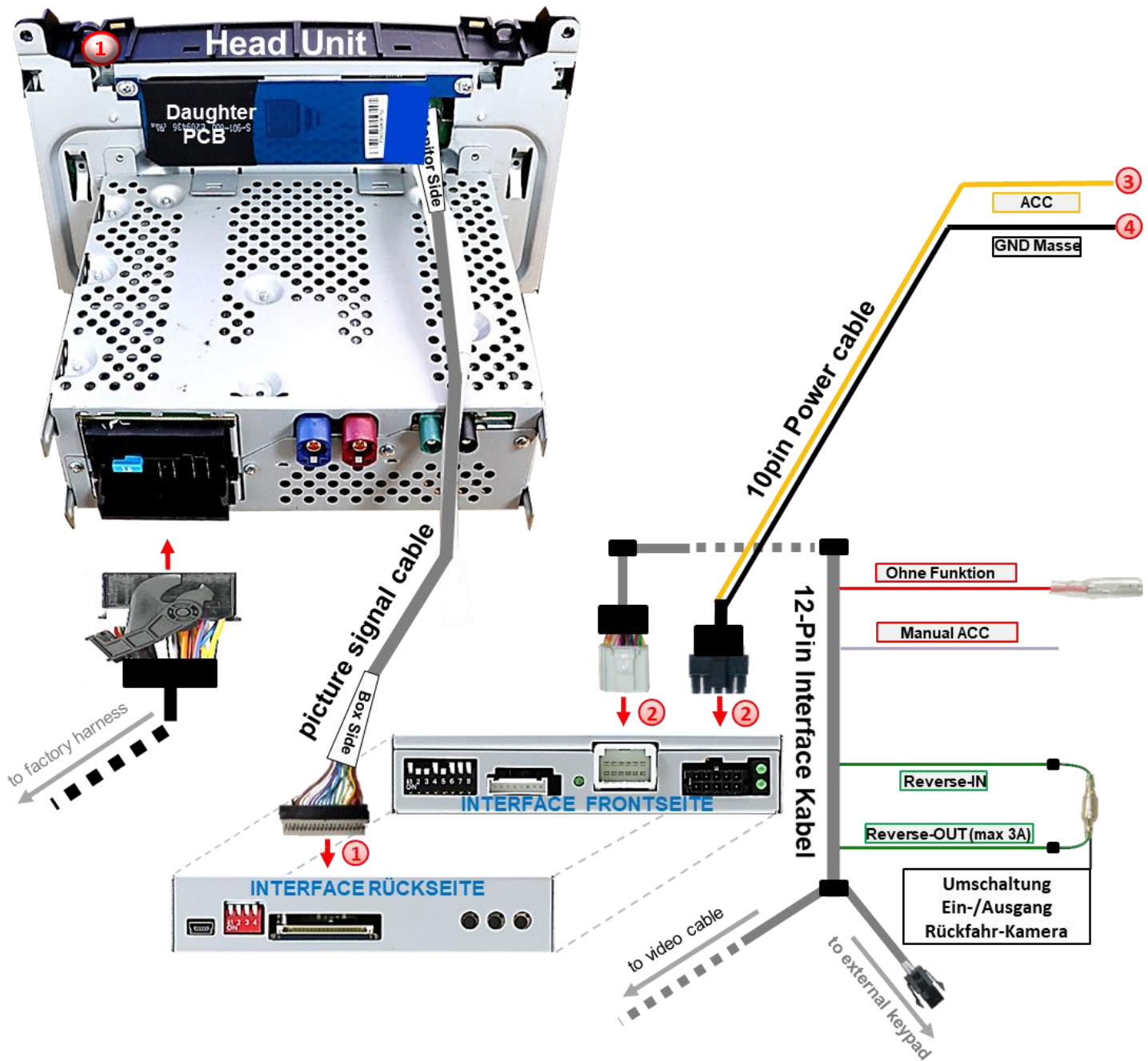

Connect the 20pin picture signal cable's female 20pin connector to the male 20pin connector of the video-interface.

- ② Connect the female 12pin connector of the 12pin interface cable to the 12pin connector of the video interface and the 10pin connector beside to the female 10pin connector of the 10pin power cable.
- ③ Connect the yellow wire of the 10pin power cable to **+12V ACC** (Accessory power) or **+12V S-contact terminal 86s** (e.g. glove compartment illumination).



For the interface power supply, the purple wire of the 12-pin interface cable has also to be connected to ACC (see following chapter).

- ④ Connect the single black wire of the 10pin power cable to vehicle's negative ground.

**Check**  
*Exceptionally, the power supply to the video interfaces may not be interrupted after switching to the vehicle's sleep mode. If the interface LEDs continue to shine even in the vehicle's sleep mode, please contact the support!*

## 2.7. Connection – purple wire

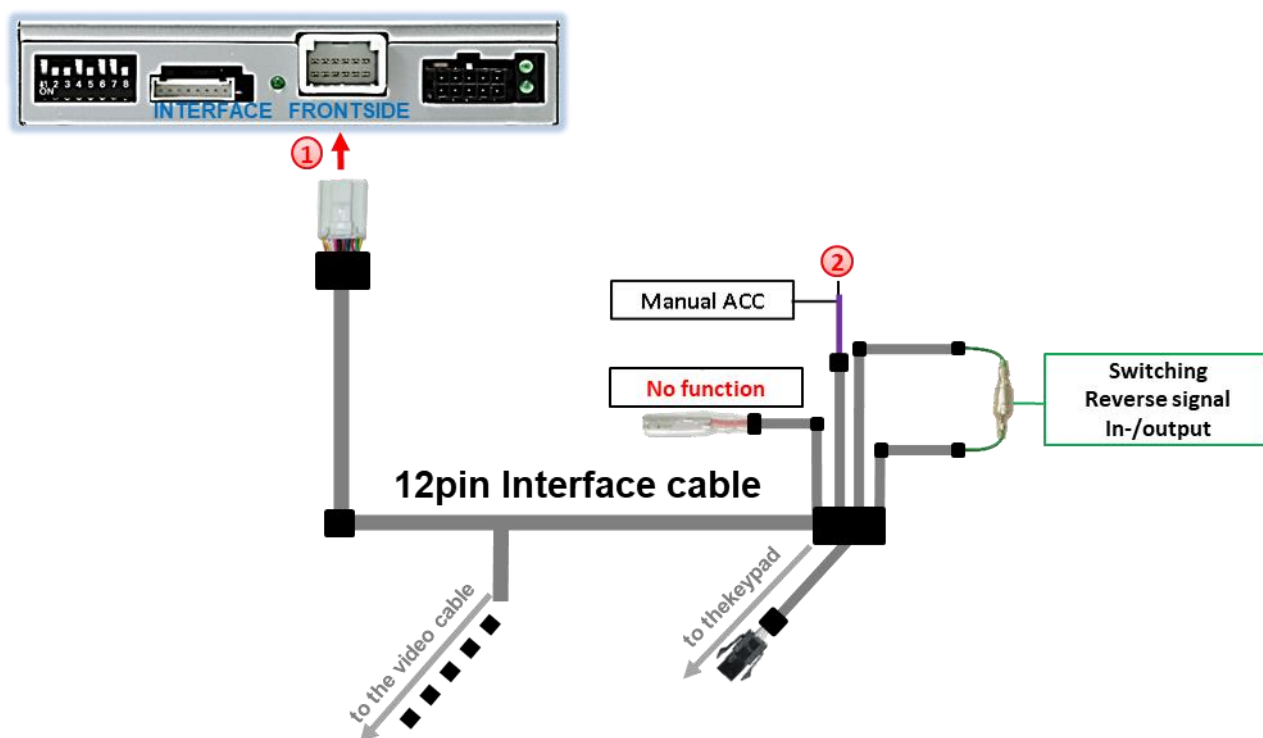

- 1 Connect the female 12pin connector of the 12pin interface cable to the male 12pin connector of the video interface.
- 2 Connect the 12pin interface cable's purple coloured wire **Manual ACC** to +12V **ACC terminal 15** or to +12V **S-contact terminal 86s +12V** (e.g. glove compartment illumination).

## 2.8. Connection - video sources

It is possible to connect two after-market AV-sources and one after-market rear-view camera to the video-interface.

Before the final installation, we recommend a test-run of the interface. Due to changes in the production of the vehicle manufacturer, there's always the possibility of incompatibility.

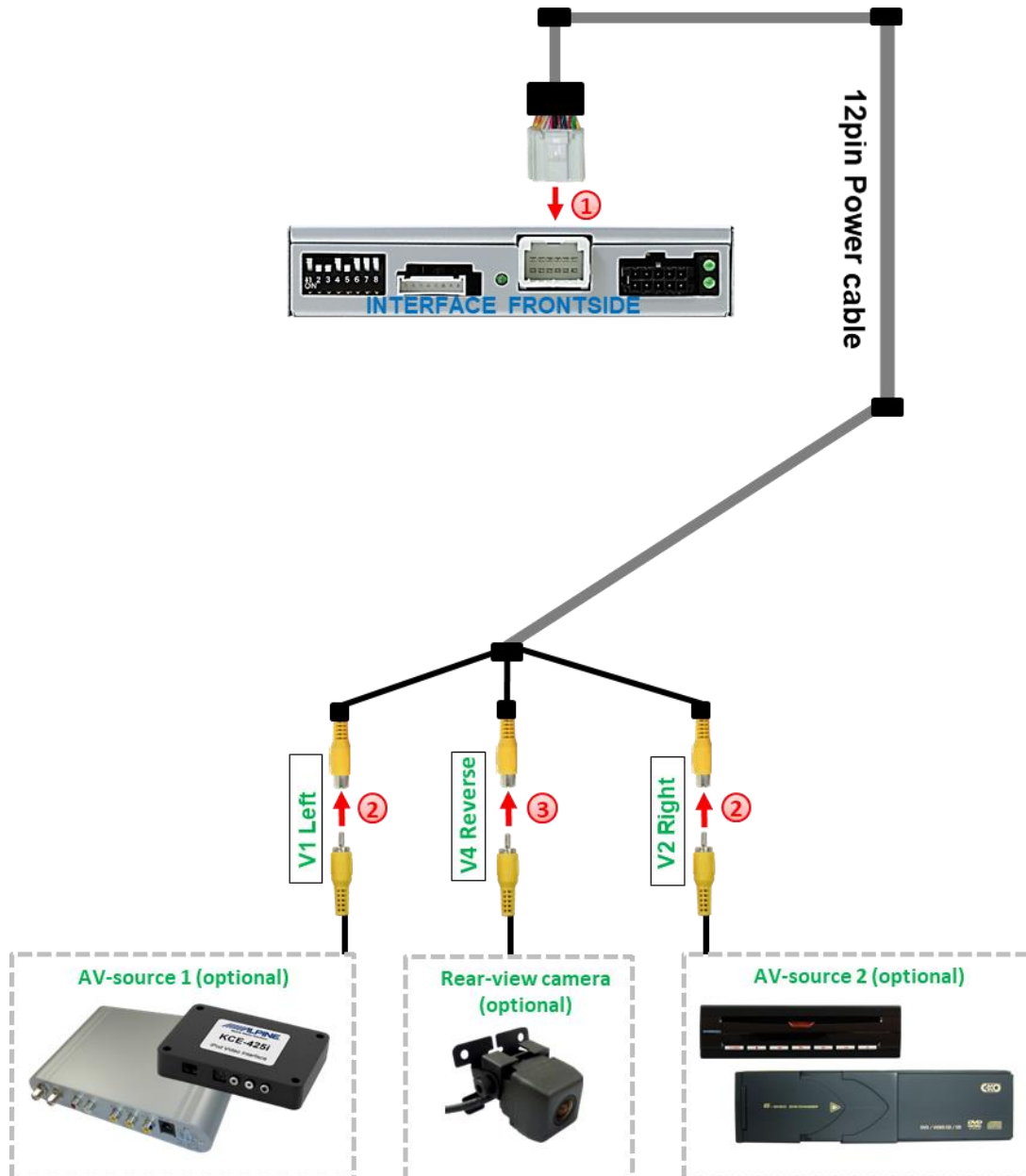

- 1 Connect the 12pin interface cable's female 12pin connector to the interface's male 12pin connector.
- 2 Connect the video RCAs of the AV-source 1 and AV source 2 to the female RCA connectors "V1 Left" and "V2 Right" of the 12pin interface cable.
- 3 Connect the video RCA of the rearview camera to the female RCA connector "V4 Reverse" of the video cable.



## 2.8.1. After-market rear-view camera

**Note:** Do not forget to set dip5 of the video-interface to ON before testing.

To automatically switch to the rear-view camera input while the reverse gear is engaged, an external switching signal from the reverse gear light is required. As the reverse gear light's power supply isn't voltage-stable all the time, an ordinary open relay (e.g AC-RW-1230 with wiring AC-RS5) or filter (e.g. AC-PNF-RVC) is required. The diagram below shows the connection type of the relay.

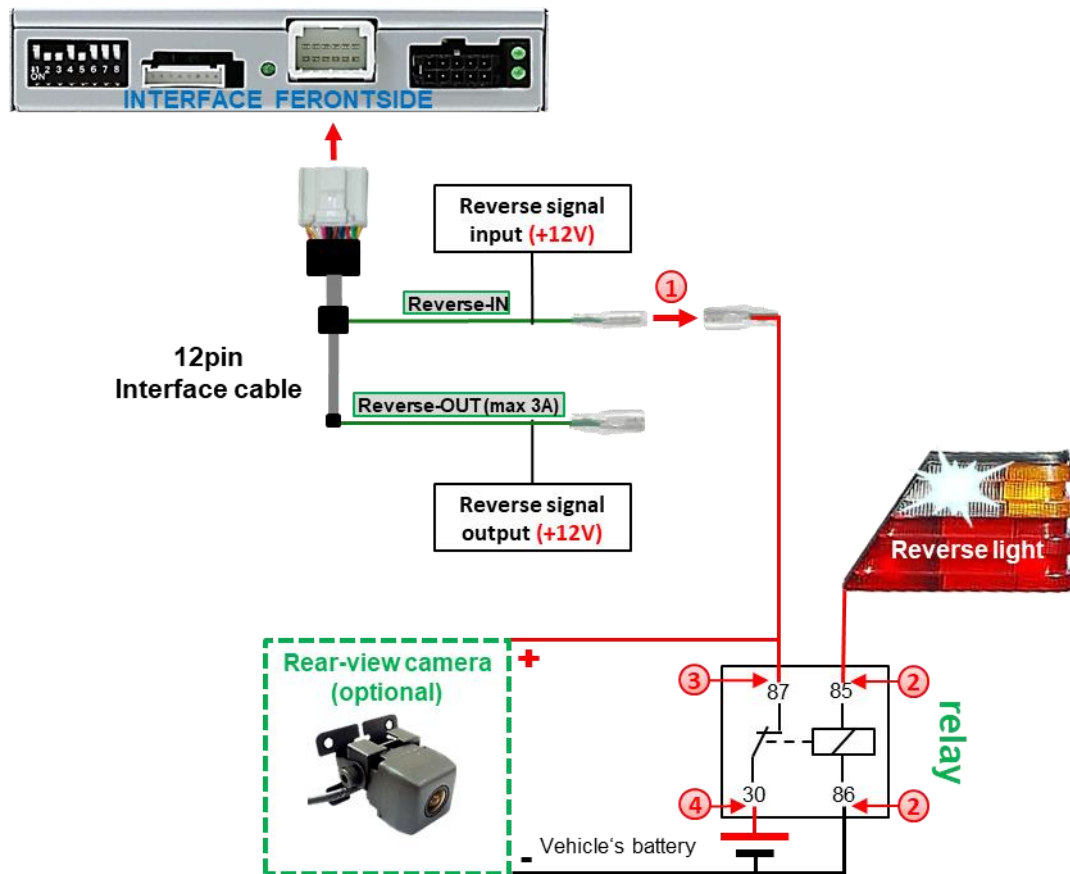

- 1 Disconnect the green cable's pre-connected male- and female connectors of the 12pin cable and connect the green input cable "Reverse-IN" to the output connector (87) of the relay.

**Note:** Not least to avoid short circuits, the best solution should be, to crimp a male 4mm connector to the relay's output cable and connect it to the green cable's female 4mm connector. The output-cable "Reverse-OUT" remains disconnected as it's out of function.

- 2 Connect the Reverse light's power-cable to coil terminal (85) and the vehicle's ground to coil terminal (86) of the relay.
- 3 Connect the output terminal (87) of the relay to the rear-view camera's power-cable, like you did it to the green "Reverse-IN" cable before.
- 4 Connect permanent power / 12V to the relay's input terminal (30).

## 2.9. Connection – external keypad

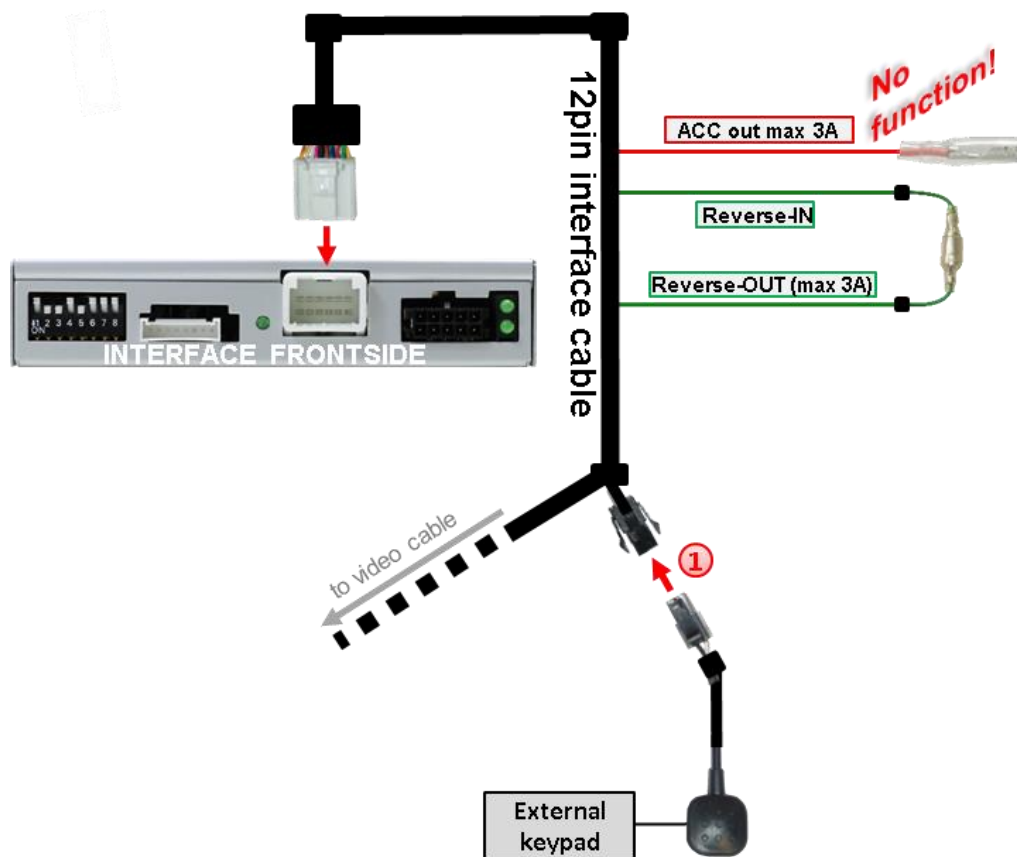

- 1 Connect the keypad's female 4pin connector to the video-interface's male 4pin connector.

Note: Even if the switching through several video sources by the keypad mightn't be required, the invisible connection and availability is strongly recommended.

## 2.10. Picture settings

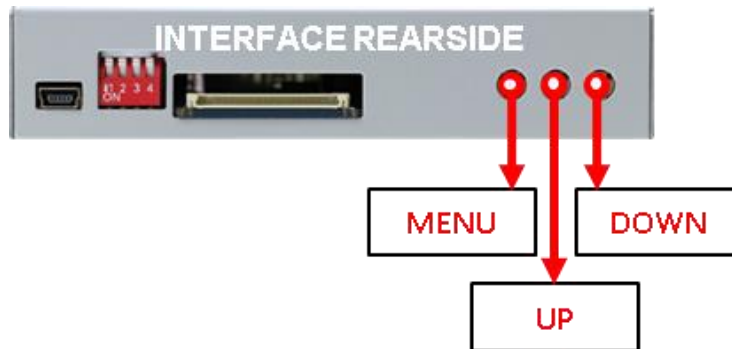

The picture settings adjustment can be done by the 3 buttons of the video-interface. Press the **MENU** button to open the OSD settings menu. To switch to the next menu item, pressing **UP** and **DOWN** will change the selected value. The buttons are embedded in the housing to avoid accidental changes during or after installation. The picture settings have to be done separately for AV1 and AV2 while the corresponding input is selected and visible on the monitor.

**Note:** The OSD menu is only shown when a working video source is connected to the selected video-input of the interface.

The following settings are available:

- Contrast
- Brightness
- Saturation
- Position H (horizontal)
- Position V (vertical)
- For the rearIR-AV1 (out of function)
- IR-AV2 (out of function)
- Guide-lines left (out of function)
- Guide-lines right (out of function)
- Guide lines (out of function)

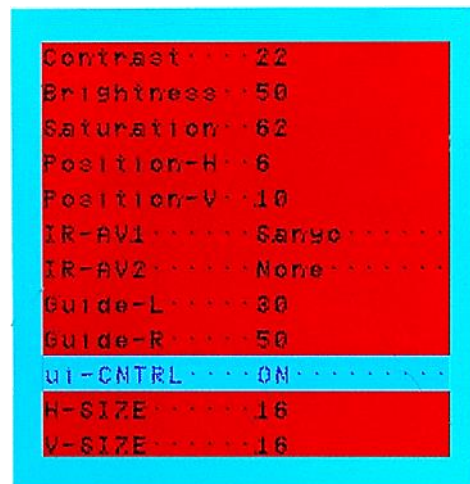

**Note:** As the system doesn't support the vehicle's CAN, the guide-lines cannot be used.

### 3. Interface operation – external keypad

The switching of video sources is done by the interface's external keypad.

- Long press of keypad (2-3 seconds)

By long pressing the external keypad (2-3 seconds), the video interfaces switches the input from the factory video to the inserted video sources.

**Note:** The interface switches after releasing the switch (after long pressure).

*Factory video → V1 Left → V2 Right → factory video →...*

By dip switch deactivated inputs will be skipped.

### 4. Specifications

BATT/ACC range	7V - 25V
Stand-by power drain	135mA
Power	135mA @12V
Video input	0.7V – 1V
Video input formats	NTSC
RGB-video amplitude	0.7V with 75 Ohm impedance
Temperature range	-40°C to +85°C
Dimensions Video-Box	116 x 23 x 86 mm (W x H x D)

## 5. FAQ – Trouble shooting Interface functions

For any troubles which may occur, check the following table for a solution before requesting support from your vendor.

Symptom	Reason	Possible solution
No picture/black picture (factory picture).	Not all connectors have been reconnected to factory head-unit or monitor after installation.	Connect missing connectors.
	No power on CAN-bus box (all LED CAN-bus box are off).	Check power supply of CAN-bus box. Check CAN-bus connection of CAN-bus box.
	CAN-bus box connected to CAN-bus in wrong place.	Refer to the manual where to connected to the CAN-bus. If not mentioned, try another place to connect to the CAN-bus.
	No power on video-interface (all LED video-interface are off).	Check whether CAN-bus box delivers +12V ACC on red wire output of 8pin to 6pin cable. If not cut wire and supply ACC +12V directly to video-interface.
No picture/black picture/white picture (inserted picture) but factory picture is OK.	No picture from video source.	Check on other monitor whether video source is OK.
	No video-source connected to the selected interface input.	Check settings dips 1 to 3 of video interface which inputs are activated and switch to corresponding input(s).
	LVDS cables plugged in wrong place.	Double-check whether order of LVDS cables is exactly connected according to manual. Plugging into head-unit does not work when the manual says to plug into monitor and vice versa.
Inserted picture totally wrong size or position.	Wrong monitor settings of video-interface.	Try different combinations of dips 7 and 8 of video-interface. Unplug 6pin power after each change.
Inserted picture double or 4 times on monitor.		
Inserted picture distorted, flickering or running vertically.	Video sources output set to AUTO or MULTI which causes a conflict with the interfaces auto detection.	Set video source output fixed to PAL or NTSC. It is best to set all video sources to the same standard.
	If error occurs only after source switching: Connected sources are not set to the same TV standard.	Set all video sources to the same standard.
	Some interfaces can only handle NTSC input.	Check manual whether there is a limitation to NTSC mentioned. If yes, set source fixed to NTSC output.
Inserted picture b/w.	Picture settings have not been adjusted.	Use the 3 buttons and the interface's OSD to adjust the picture settings for the corresponding video input.
Inserted picture qual. bad.		
Inserted picture size slightly wrong.		
Inserted picture position wrong.		
Camera input picture flickers.	Camera is being tested under fluorescent light which shines directly into the camera.	Test camera under natural light outside the garage.
Camera input picture is bluish.	Protection sticker not removed from camera lens.	Remove protection sticker from lens.

Symptom	Reason	Possible solution
Camera input picture black.	Camera power taken directly from reverse gear lamp.	Use relay or electronics to "clean" reverse gear lamp power. Alternatively, if CAN-bus box is compatible with the vehicle, camera power can be taken from green wire of 6pin to 8pin cable.
Camera input picture has distortion.		
Camera input picture settings cannot be adjusted.	Camera input picture settings can only be adjusted in AV2 mode.	Set dip 3 of video-interface to ON (if not input AV2 is not already activated) and connect the camera to AV2. Switch to AV2 and adjust settings. Reconnect camera to camera input and deactivate AV2 if not used for other source.
Graphics of a car in camera input picture.	Function PDC is ON in the interface OSD.	In compatible vehicles, the graphics will display the factory PDC distance. If not working or not wanted, set interface OSD menu item UI-CNTRL to ALLOFF.
Chinese signs in camera input picture	Function RET or ALL is ON (function for Asian market) in the interface OSD.	Set interface OSD menu item UI-CNTRL to ALLOFF or PDCON.
Not possible to switch video sources by OEM button.	CAN-bus interface does not support this function for vehicle.	Use external keypad or cut white wire of 6pin to 8pin cable and apply +12V impulses for AV-switching.
Not possible to switch video sources by external keypad.	Pressed too short.	For video source switching a longer press of about 2.5 seconds is required.
	SW-version of interface does not support external keypad.	Use OEM-button or cut white wire of 6pin to 8pin cable and apply +12V impulses for AV-switching.
Interface does not switch to camera input when reverse gear is engaged.	CAN-bus interface does not support this function for the vehicles.	Cut the green wire of the 6pin to 8pin cable and apply +12V constant from reverse gear-lamp signal. Use relay to "clean" R-gear lamp power.
Interface switches video-sources by itself.	CAN-bus interface compatibility to vehicle is limited.	Cut the grey wire of 6pin to 8pin and isolate both ends. If problem still occurs, additionally cut the white wire of 6pin to 8pin cable and isolate both ends.

## 6. Technical Support

Please note that direct technical support is only available for products purchased directly from NavLinkz GmbH. For products bought from other sources, contact your vendor for technical support.

**NavLinkz GmbH**  
**distribution/tech dealer-support**  
 Heidberghof 2  
 D-47495 Rheinberg

Tel +49 2843 17595 00  
 Email mail@navlinkz.de

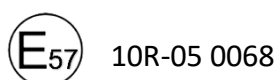

Made in China

