

r.LiNK Video-Insertter

RL2-MBN51

**for Mercedes Benz vehicles
with Comand Online NTG5/NTG5.1
Audio20 CD NTG5/NTG5.1
Audio20 USB NTG5/NTG5.1
with 4pin HSD LVDS connector to monitor**

**Video-insertter for front- and rear-view camera input
and additional video source**

Product Features

- **Video-Insertter for Factory-Infotainment Monitors**
- **Rear and Front Camera FBAS Input**
- **FBAS Video Input for After-Market Devices (e.g. DVD-Player, DVD-Tuner)**
- **Automatic Switching to Rear View Camera, Input by Engagement of Reverse Gear**
- **Manual Switching to Front Camera by Keypad or Comand-Button**
- **Activatable Parking Guide Lines for Rear-View Camera (not all vehicles)**
- **Video-in-motion (ONLY for connected video-sources)**
- **AV-inputs PAL/NTSC compatible**

Contents

1. Prior to installation

- 1.1. Delivery contents
- 1.2. Checking the compatibility of vehicle and accessories
- 1.3. Boxes and connectors
 - 1.3.1. Video-interface
 - 1.3.2. CAN-bus box
- 1.4. Dip-switch settings
 - 1.4.1. Enabling the interface's video inputs (dip 2-3)
 - 1.4.2. Rear View Camera Settings (dip 5))
 - 1.4.3. Monitor Selection (dip 7-8)
- 1.5 Dip Switch Setting Can-Box

2. Installation

- 2.1. Place of installation
- 2.2. Connection Scheme
- 2.3. Connection Video Interface and Can-Box
- 2.4. Connection to Head Unit - LVDS
- 2.5. Connection to the head-unit - Quadlock
- 2.6. Connecting Peripheral Devices
 - 2.6.1. After-market rear-view camera
 - 2.6.1.1 Case 1: CAN-Box supports Reverse Gear
 - 2.6.1.2 Case 2: CAN Box does not support Reverse Gear
 - 2.6.1.3 Connection Video Signal of rear-view camera
 - 2.6.2. After Market Front Camera
 - 2.6.3 After Market Video Source
 - 2.6.4 Audio insertion
- 2.7 Connecting Video-Interface and Keypad
- 2.8 Picture settings and guide lines

3. Interface Operation

- 3.1 By Comand-buttons
- 3.2 By keypad

4. Specifications

5. Frequently asked questions

6. Technical support

Legal Information

By law, watching moving pictures while driving is prohibited, the driver must not be distracted. We do not accept any liability for material damage or personal injury resulting, directly or indirectly, from installation or operation of this product. This product should only be used while standing or to display fixed menus or rear-view-camera video when the vehicle is moving, for example the MP3 menu for DVD upgrades.

Changes/updates of the vehicle's software can cause malfunctions of the interface. If available, we offer free software-updates for our interfaces for one year after purchase. To receive a free update, the interface must be sent in at own cost. Labor cost for and other expenses involved with the software-updates will not be refunded.

1. Prior to installation

Read the manual prior to installation.

Technical knowledge is necessary for installation. The place of installation must be free of moisture and away from heat sources.

1.1. Delivery contents

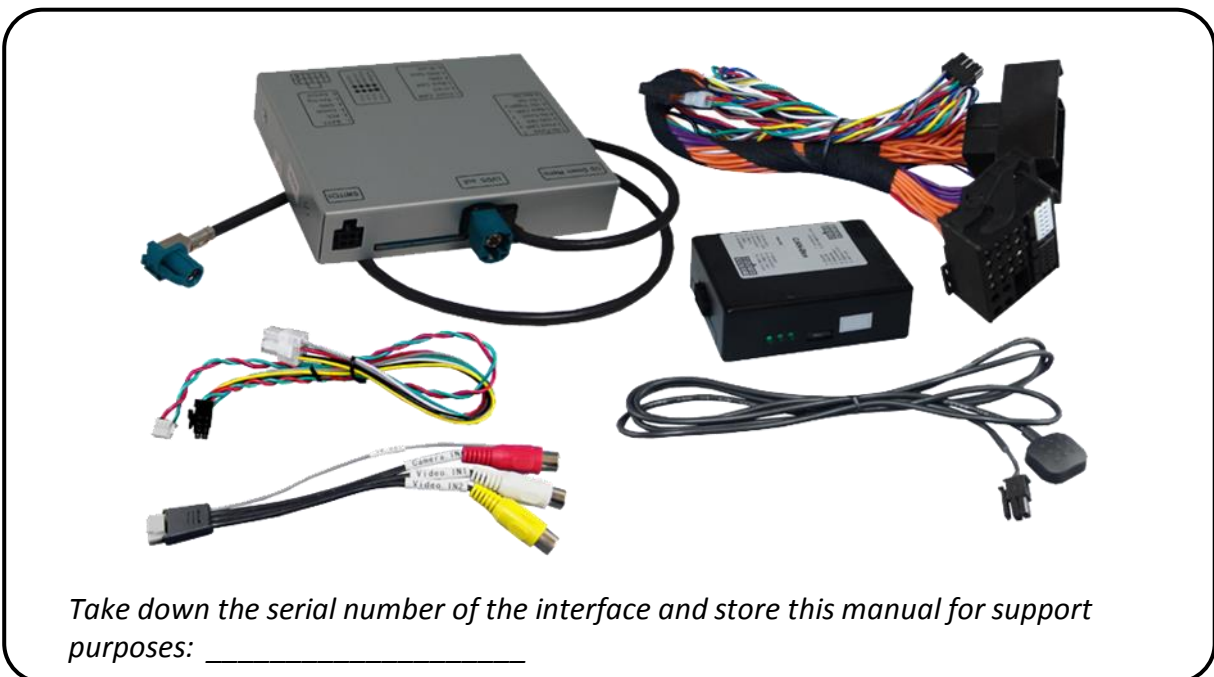

1.2. Checking the compatibility of vehicle and accessories

Requirements	
<i>Vehicle</i>	A-class (W176) from about 09/2015, B-class (W246) from about 11/2014, C-class (W205), C-class Coupé (C202) from about 2015, CLA-Coupé (C117) from about 10/2014, CLA-Shooting B (X117) from 03/2015, CLS-Coupe (W218) from about 08/2014, E-class (S/W212) from about 11/2014, V-class (W447) from 2014 Vito (V/W447) is NOT compatible
<i>Head-unit/monitor</i>	Comand Online NTG5/5.1 Audio20 CD NTG5/5.1 Audio 20 USB NTG5/5.1 with 4pin HSD LVDS Connector to Monitor
Limitations	
<i>Video only</i>	The interface inserts ONLY video signals into the infotainment. For audio insertion a factory audio-AUX input with A2DP Audio Streaming via Bluetooth (Art. No. AUX.A2DP) or FM-Modulator is required.
<i>Video Sources</i> <	Only compatible to NTSC Video Sources
<i>Factory Rear View Camera</i>	Automatical switching to Rear Rear View Camera as long as the Rerverse Gear is engaged. For Retardation of Switch-Back additional Electronics is required.

1.3. Boxes and connectors

1.3.1. Video-interface

The video-interface converts the connected after-market sources video signals to an LVDS signal which is the inserted into the factory monitor on certain trigger options.

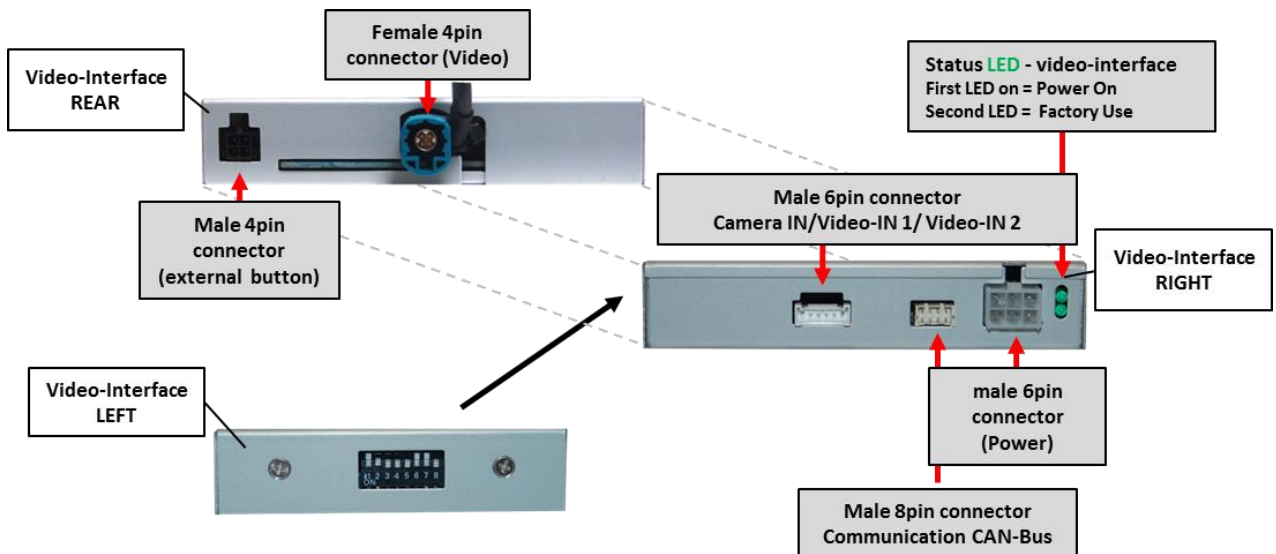

1.3.2. CAN-Bus Box

The CAN-bus box reads digital signals from the CAN-bus and converts them for the video-interface.

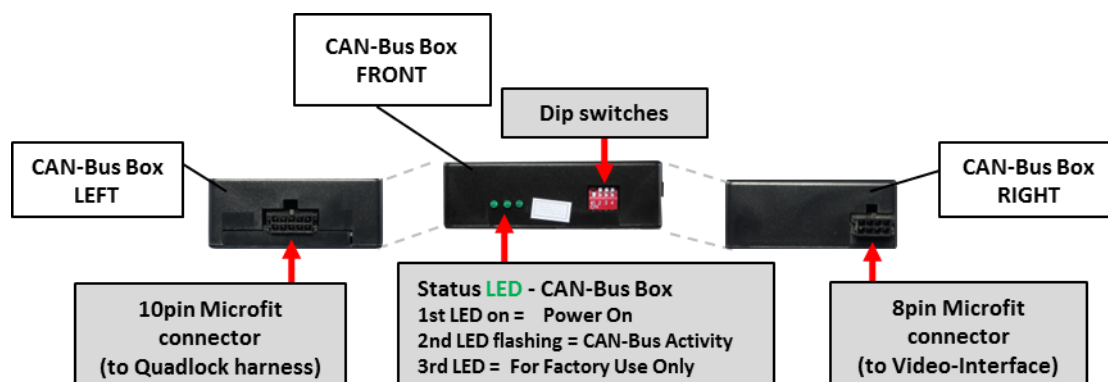

1.4. Dip-switch settings

Some settings must be selected by the dip-switches on the video-interface. Dip position down is ON and position up is OFF.

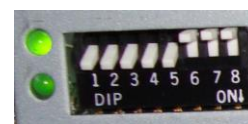

Dip	Function	ON (down)	OFF (up)
1	No Function		Set OFF
2	Input Front Camera	enabled	disabled
3	Video 2	enabled	disabled
4	No Function		Switch to OFF
5	Rear-view cam type	After-Market	Factory or none
6	No function	-	Set OFF
7	Monitor selection	Try all 4 possible combinations of dip 7 and 8 to find the best picture (quality and size)	
8	Monitor selection		

See following chapters for detailed information.

1.4.1. Enabling the interface's video inputs (dip 2-3)

Only the enabled video inputs can be accessed when switching through the interface's video sources. It is recommended to enable only the required inputs for the disabled will be skipped when switching through the video-interfaces inputs.

1.4.2. Rear-view camera setting (dip 5)

If set to OFF, the interface switches to factory LVDS picture while the reverse gear is engaged to display factory rear-view camera or factory optical park system picture.

If set to ON, the interface switches to its rear-view camera input CAM while the reverse gear is engaged.

1.4.3. Monitor selection (dip 7-8)

Dip 7 and 8 are for monitor-specific video settings which cannot be predicted as even within the same head-unit version, the monitor specifications may vary. It is necessary to try all possible combinations (both OFF, both ON, 7 OFF and 8 ON, 7 ON and 8 OFF) - while a working video source is connected to the chosen input of the interface - to see which combination gives the best picture quality and size (some may give no picture). It is possible to first hot plug through the dip combinations, but if you do not experience any change of picture after trying all 4 options, retry and disconnected the 6pin power plug of the video-box between every change of the dip setting.

1.5 Dip Switch Settings of Can-Box

Dip Position "Down" is ON and position "Up" is OFF.



Fahrzeug/Navigation	Dip 1	Dip 2	Dip 3	Dip 4
Fahrzeuge mit NTG5	OFF	OFF	OFF	OFF
Fahrzeuge mit NTG5.1	OFF	OFF	ON	OFF

2. Installation

Switch off ignition and disconnect the vehicle's battery! The interface needs a permanent 12V source. If according to factory rules disconnecting the battery is to be avoided, it is usually sufficient to put the vehicle in sleep-mode. In case the sleep-mode does not show success, disconnect the battery with a resistor lead.

If power source is not taken directly from the battery, the connection has to be checked for being start-up proven and permanent.

2.1. Place of installation

The interface is installed on the backside of the head-unit.

2.2. Connection Scheme

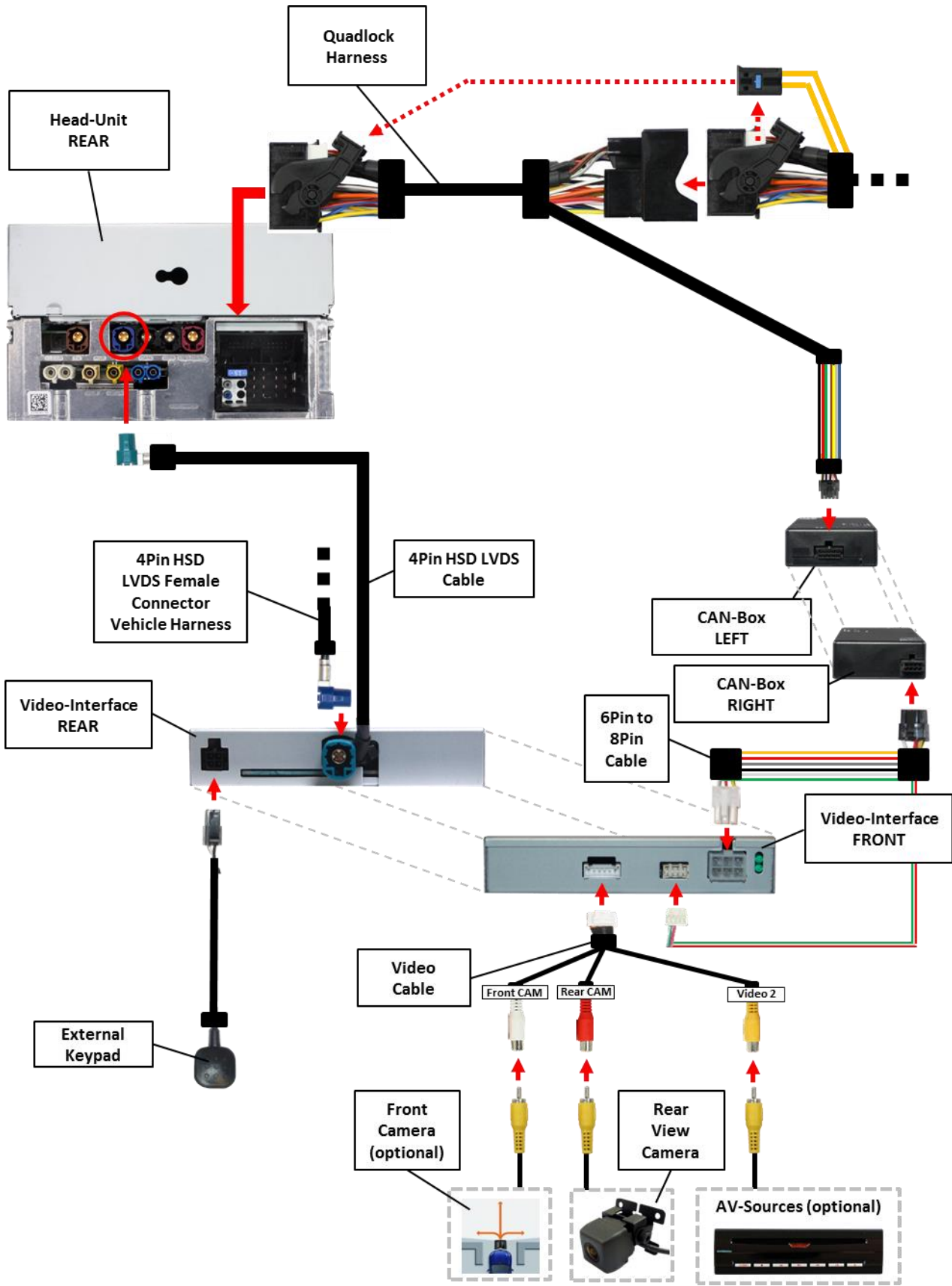

2.3 Connecting video-interface and CAN-box

The CAN-Bus Box reads digital signals from the CAN-Bus and converts them for the video-interface. ACC +12V max. 0.5A (red wire of 6pin) and reverse gear +12V max. 0.5A (green wire of 6pin) constant signal. Additionally there is a data exchange, e.g. for steering wheel position for driving path lines (green-red twisted cable of 6pin to 8pin cable).

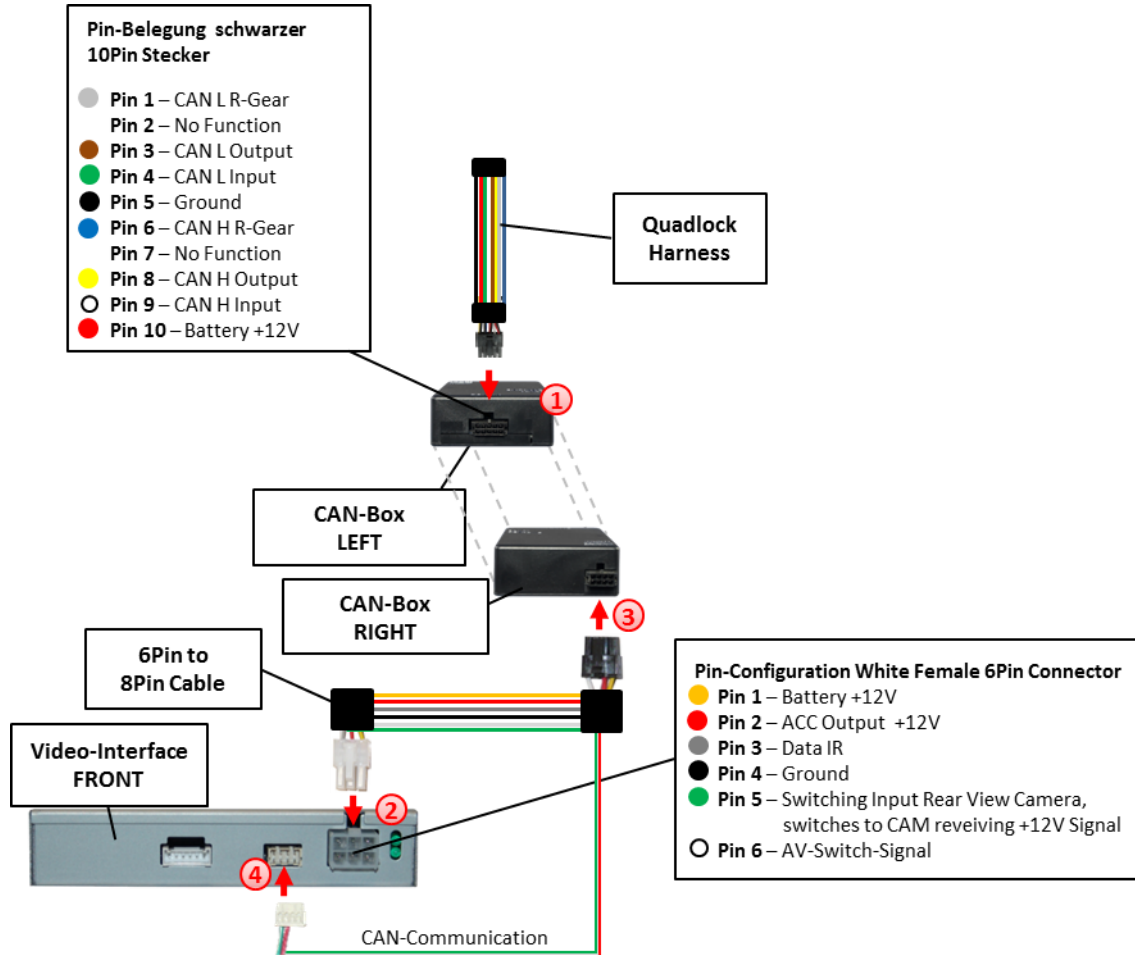

- ① Connect black female 10pin Microfit connector of the Quadlock harness to the male 10pin Microfit connector of the CAN-box.

Note: Check LEDs on CAN-box after reconnecting the battery, two must be on.

- ② Connect white female 6pin Molex connector of the 6pin to 8pin cable to the male 6pin Molex connector of the video-interface.

- ③ Connect black female 8pin Microfit connector of the 6pin to 8pin cable to male 8pin Microfit connector of the CAN-box.

Note: Check LEDs on video-interface after reconnecting the battery, one must be on.

- ④ Connect the red and green twisted wire of 6Pin to 8Pin cables to 4Pin female connector of Video-Interface

Note: The CAN-box is not compatible with all vehicles. If the CAN-Box does not deliver ACC to pin2 of the video-interface or blocks the vehicle CAN, it is possible to install without CAN-Box. In this case see also note in chapter after-market rear-view camera if one is supposed to be connected.

2.4 Connections to Head Unit LVDS

Remove Comand Head-Unit.

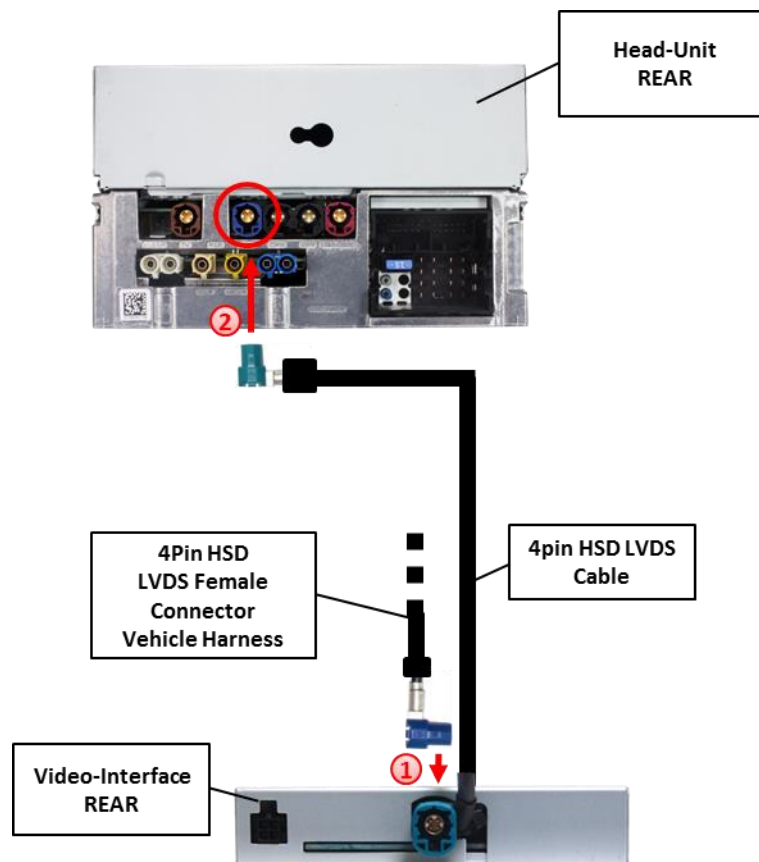

- ① Remove blue female 4pin HSD LVDS connector from the rear of the factory monitor and connect it to the male 4pin HSD LVDS connector of the 4pin HSD LVDS cable.
- ② Connect female 4pin connector of the 4pin HSD LVDS cable to the male 4pin HSD LVDS connector of Head-Unit.

2.5 Connections to the Head-Unit Quadlock

Remove head-unit.

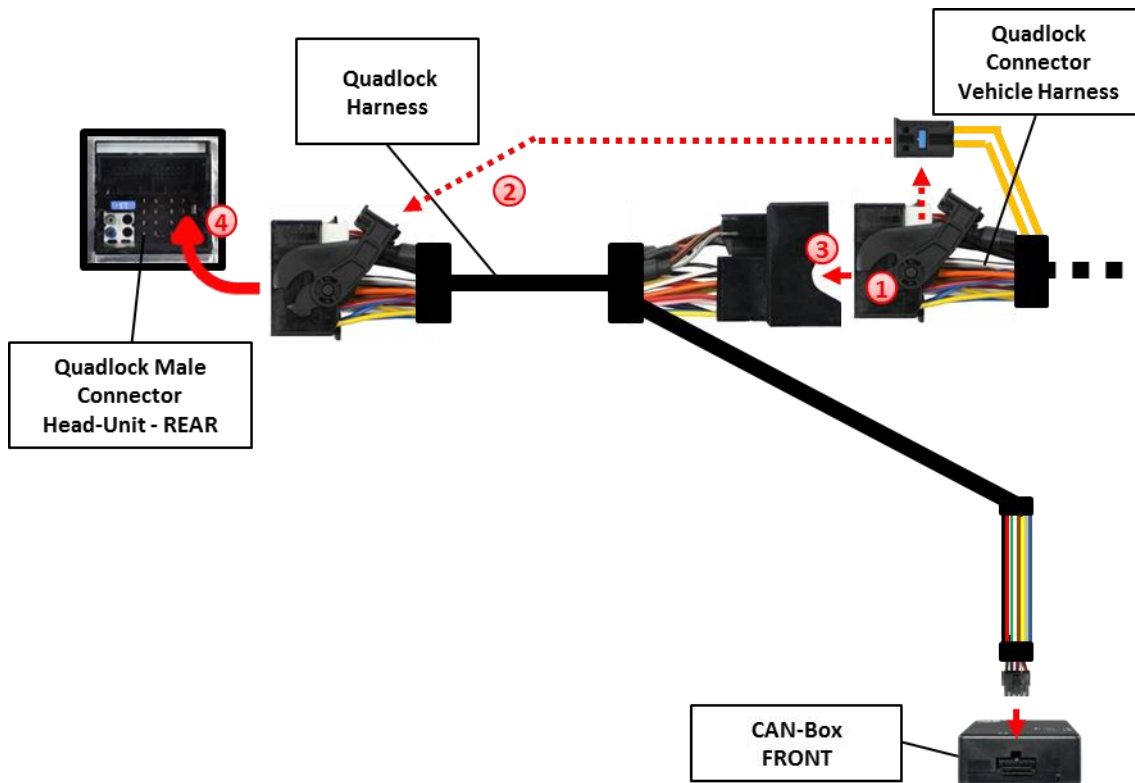

- 1 Remove the female Quadlock connector of the vehicle harness from the rear of Head-Unit.
- 2 Remove optical leads –if existing- from the female Quadlock connector of the vehicle harness and insert them into the female Quadlock connector of Quadlock harness at the same position.
- 3 Connect female Quadlock Connector of vehicle harness to the male Quadlock Connector of Quadlock Harness.
- 4 Connect female Quadlock Connector of Quadlock Harness to the male Quadlock Connector of Head-Unit.

2.6 Connecting peripheral devices

It is possible to connect an after-market rear-view camera, an after-market front camera and an after-market AV-source to the video-interface.

Before final installation of the peripheral devices, we recommend a test-run of the interface. Due to changes in the production of the vehicle manufacturer is always the possibility of incompatibility.

2.6.1 After-Market Rear View Camera

Some vehicles have a different reverse gear code on the Can-Bus, which is not compatible to the CAN-Box included in the scope of delivery. For this reason there are two possibilities of installation. If the Can-Box supports the reverse gear, the green wire of the 6Pin to 8pin cable is occupied by +12V, as long as the reverse gear is engaged.

Note: Before testing, please, don't forget to shift the Dip 5 of the Video Interface to ON.

2.6.1.1 Case 1: CAN-Box supports Reverse Gear

In case the Can-Bus-Box delivers +12V to the green wire 6Pin to 8pin cable while reverse gear is engaged, the Interface switches automatically to CAM input.

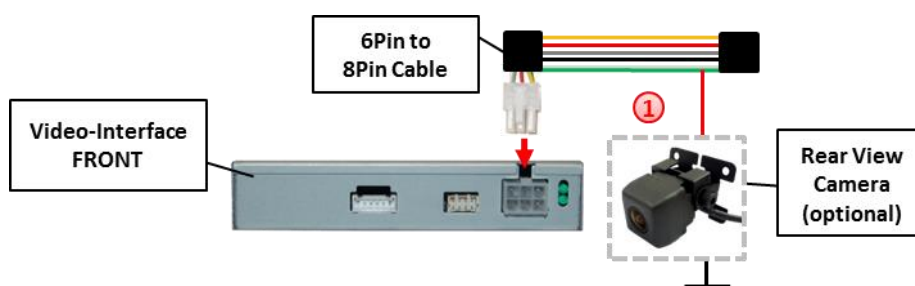

- ① In addition power supply of +12V (500mA max.) of the After-Market Rear View Camera can be realised by the green wire of of 6Pin to 8pin cable

2.6.1.2 Case 2: Can Box does not support reverse gear

In case the Can-Bus-Box **does not** deliver +12V to the green wire 6Pin to 8pin cable while reverse gear is engaged (not all of the vehicles are compatible) an external switch-over signal of the reverse light will be required. Because of the fact that the reverse light signal is not free from electronic interferences, a relay (eg. AC-RW-1230 with AC RS5 wiring) or an interference filter (e.g. AC-PNF-RVC) will be required. The diagram below shows the use of the relay.

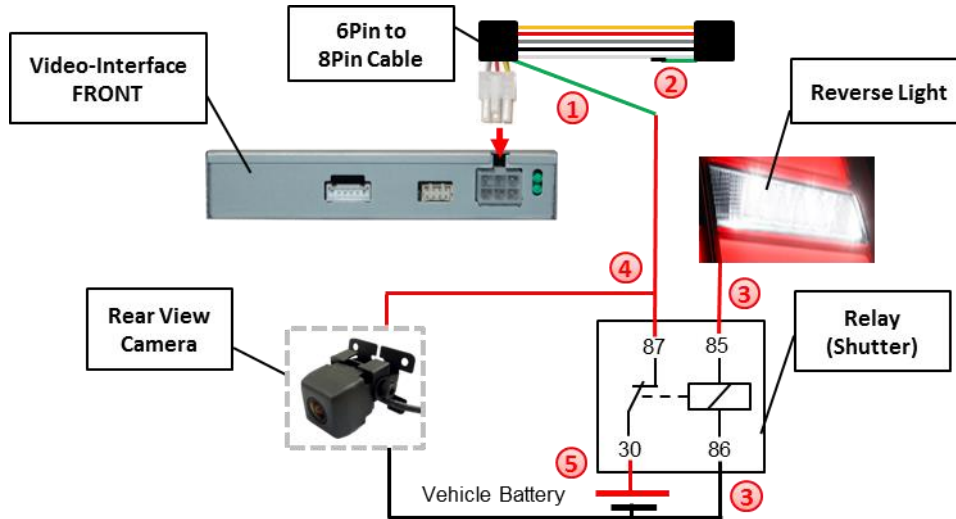

- ① Disconnect green cable of 6pin to 8pin cable near the black 8pin connector .
- ② Isolate short end of the green cable (CAN-Box side).
- ③ Connect Reverselight/Power with Coil (85) and Ground (86) to relay.
- ④ Connect power of rear view camera and the green cable (Video Interface side) of 6pin to 8pin cable with relay output (87)
- ⑤ Connect continuous battery current to relay input (87)

2.6.1.3 Video Signal Connection to Rear View Camera

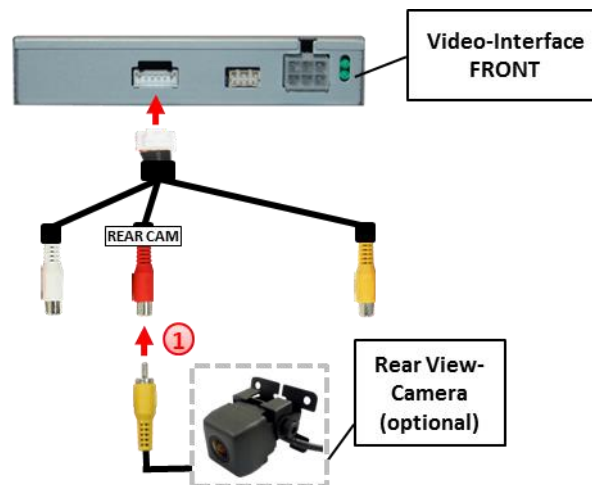

- ① Connect the video-RCA of the after-market rear-view camera to the female RCA port of the video-interface which is labeled as CAM.

2.6.2 After Market Front Camera

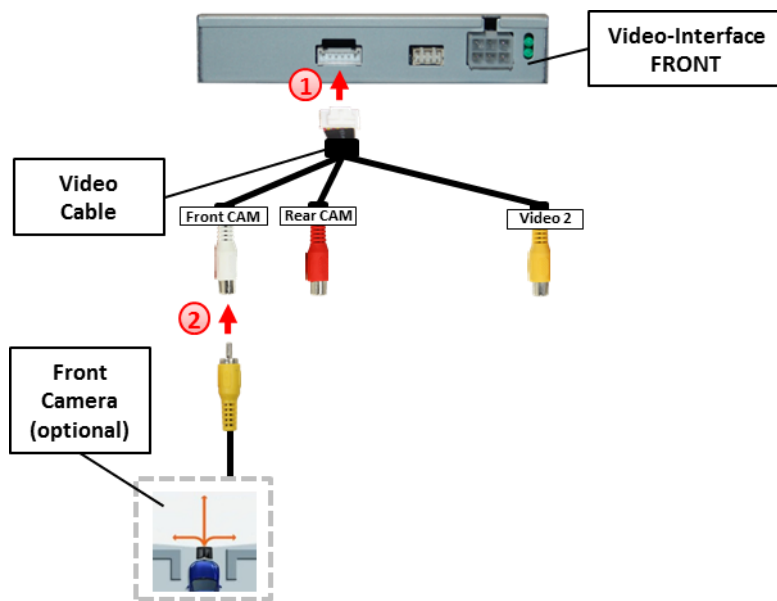

- ① Connect 6pin male connector of video cable to 6pin female connector of video interface
- ② Connect male RCA of front camera to the white female RCA “Front Cam” of video Cable

Note: There is no automatic switch to front camera. Only manual switching by keypad or Comand button.

2.6.3 After Market Video Source

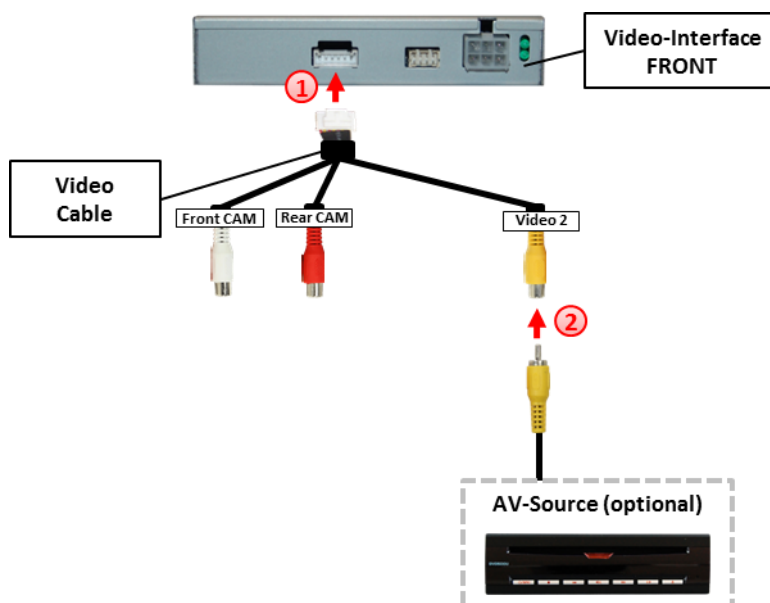

- ① Connect 6pin male connector of video cable to female 6pin connector of video interface
- ② Connect video RCA of video source to yellow RCA "Video2" of video cable.

2.6.4 Audio Insertion

This interface can only insert video signals into the factory infotainment. If an AV-source is connected, audio insertion must be done by factory audio AUX input with A2DP Audio Streaming by Bluetooth (Art. Nr. AUX-A2DP) or FM-modulator. The inserted video-signal can be activated simultaneously to each audio-mode of the factory infotainment.

2.7 Connection Video Interface and External Keypad

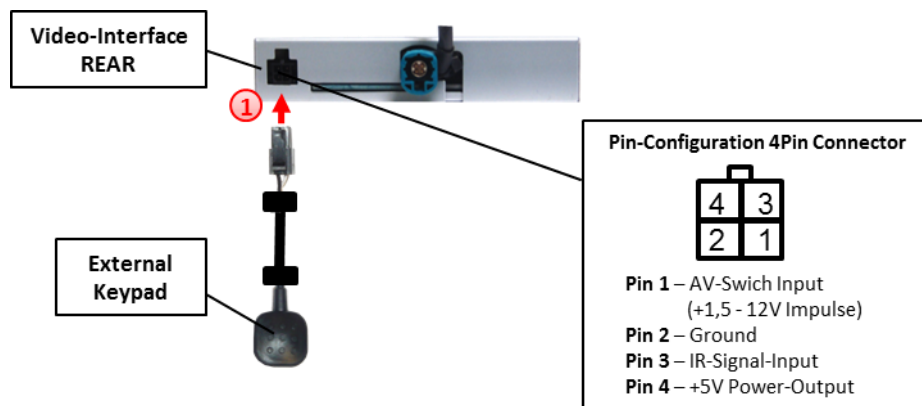

- 1 Connect 4pin female Microfit connector of external keypad to male 4pin Microfit connector of video interface

2.8 Picture settings and guide lines

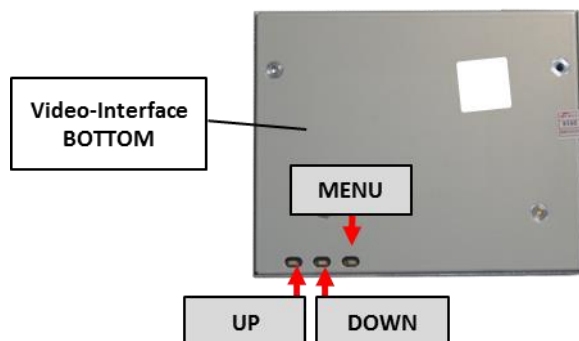

The picture settings are adjusted by the 3 buttons on the video-interface. Press the MENU button to open the OSD settings menu or to switch to the next menu item. Press UP and DOWN change the selected value. The buttons are embedded in the housing to avoid accidental changes during or after installation. Picture settings must be done separately for RGB, AV1 and AV2 while the corresponding input is selected and visible on the monitor. AV2 and CAM share the same settings which must be adjusted in AV2.

Note: The OSD menu is only shown when a working video source is connected to the selected video-input of the interface.

The following settings are available:

- Brightness
- Contrast
- Saturation
- Position H (horizontal)
- Position V (vertical)
- Guide lines (ON/OFF)

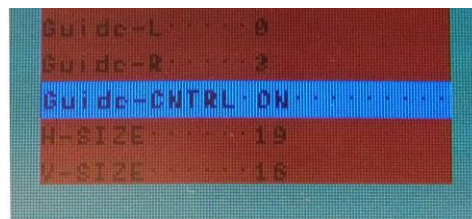

Note: If the CAN-box does not support the very vehicle, the guide-lines cannot be used. If supported and activated, the guide-line also show the steering wheel position dependant driving path.

3. Interface operation

3.1. By Comand-buttons

The .NAVI button or the BACK button (only centre console controls) switch the input factory video to inserted video. In case all inputs are activated the order is as follows:

Factory video → RGB-in → video IN1 → video IN2 → factory video →...

Inputs which are not enabled by dip switch settings are skipped.

Switchover by vehicle buttons isn't possible in all vehicles. In some vehicles the external keypad must be used.

Note: The white wire of the 6pin cable can be used with a +5-12V pulse to switch the video-sources alternatively.

3.2. By keypad

Alternatively or additionally to the factory infotainment buttons the interface's external keypad can be used to switch the enabled inputs.

4. Specifications

BATT/ACC range	7V ~ 25V
Stand-by power drain	<10mA
Power consumption	4,8W
Video input formats	PAL/NTSC
RGB-video amplitude	0.7V with 75 Ohm impedance
Temperature range	-40°C to +85°C
Weight	313g
Dimensions (box only) B x H x T	113 x 22 x 92 mm

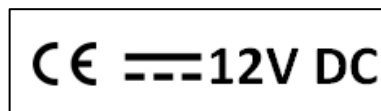

5. Frequently asked questions

For any troubles which may occur, check the following table for a solution before requesting support from your vendor.

Symptom	Reason	Possible solution
No picture/black picture (factory picture).	Not all connectors have been reconnected to factory head-unit or monitor after installation.	Connect missing connectors.
	No power on CAN-bus box (all LED CAN-bus box are off).	Check power supply of CAN-bus box. Check CAN-bus connection of CAN-bus box.
	CAN-bus box connected to CAN-bus in wrong place.	Refer to the manual where to connected to the CAN-bus. If not mentioned, try another place to connect to the CAN-bus.
	No power on video-interface (all LED video-interface are off).	Check whether CAN-bus box delivers +12V ACC on red wire output of 8pin to 6pin cable. If not cut wire and supply ACC +12V directly to video-interface.
No picture/black picture/white picture (inserted picture) but factory picture is OK.	No picture from video source.	Check on other monitor whether video source is OK.
	No video-source connected to the selected interface input.	Check settings dips 1 to 3 of video interface which inputs are activated and switch to corresponding input(s).
	LVDS cables plugged in wrong place.	Double-check whether order of LVDS cables is exactly connected according to manual. Plugging into head-unit does not work when the manual says to plug into monitor and vice versa.
Inserted picture totally wrong size or position.	Wrong monitor settings of video-interface.	Try different combinations of dips 7 and 8 of video-interface. Unplug 6pin power after each change.
Inserted picture double or 4 times on monitor.		
Inserted picture distorted, flickering or running vertically.	Video sources output set to AUTO or MULTI which causes a conflict with the interfaces auto detection.	Set video source output fixed to PAL or NTSC. It is best to set all video sources to the same standard.
	If error occurs only after source switching: Connected sources are not set to the same TV standard.	Set all video sources to the same standard.
	Some interfaces can only handle NTSC input.	Check manual whether there is a limitation to NTSC mentioned. If yes, set source fixed to NTSC output.
Inserted picture b/w.	Picture settings have not been adjusted.	Use the 3 buttons and the interface's OSD to adjust the picture settings for the corresponding video input.
Inserted picture qual. bad.		
Inserted picture size slightly wrong.		
Inserted picture position wrong.		
Camera input picture flickers.	Camera is being tested under fluorescent light which shines directly into the camera.	Test camera under natural light outside the garage.
Camera input picture is bluish.	Protection sticker not removed from camera lens.	Remove protection sticker.

Symptom	Reason	Possible solution
Camera input picture black.	Camera power taken directly from reverse gear lamp.	Use relay or electronics to "clean" reverse gear lamp power. Alternatively, if CAN-bus box is compatible with the vehicle, camera power can be taken from green wire of 6pin to 8pin cable.
Camera input picture has distortion.		
Camera input picture settings cannot be adjusted.	Camera input picture settings can only be adjusted in AV2 mode.	Set dip 3 of video-interface to ON (if not input AV2 is not already activated) and connect the camera to AV2. Switch to AV2 and adjust settings. Reconnect camera to camera input and deactivate AV2 if not used for other source.
Graphics of a car in camera input picture.	Function PDC is ON in the interface OSD.	In compatible vehicles, the graphics will display the factory PDC distance. If not working or not wanted, set interface OSD menu item UI-CNTRL to ALLOFF.
Chinese signs in camera input picture	Function RET or ALL is ON (function for Asian market) in the interface OSD.	Set interface OSD menu item UI-CNTRL to ALLOFF or PDCON.
Not possible to switch video sources by OEM button.	CAN-bus interface does not support this function for vehicle.	Use external keypad or cut white wire of 6pin to 8pin cable and apply +12V impulses for AV-switching.
Not possible to switch video sources by external keypad.	Pressed too short.	For video source switching a longer press of about 2.5 seconds is required.
	SW-version of interface does not support external keypad.	Use OEM-button or cut white wire of 6pin to 8pin cable and apply +12V impulses for AV-switching.
Interface does not switch to camera input when reverse gear is engaged.	CAN-bus interface does not support this function for the vehicles.	Cut the green wire of the 6pin to 8pin cable and apply +12V constant from reverse gear-lamp signal. Use relay to "clean" gear lamp power.
Interface switches video-sources by itself.	CAN-bus interface compatibility to vehicle is limited.	Cut the grey wire of 6pin to 8pin and isolate both ends. If problem still occurs, additionally cut the white wire of 6pin to 8pin cable and isolate both ends.

6. Technical Support

Please note that direct technical support is only available for products purchased directly from NavLinkz GmbH. For products bought from other sources, contact your vendor for technical support.

NavLinkz GmbH
distribution/tech dealer-support
Eurotec-Ring 45
D-47445 Moers

Tel +49 2841 949970
Email mail@navlinkz.de

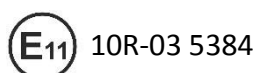

Made in China

